

SUPER FINISH 23 PRO AIRLESS HIGH-PRESSURE SPRAYING UNIT ORIGINALBETRIEBSANLEITUNG



| | | |
|--------|--------------------------------|-----------|
| - D - | Betriebsanleitung | 2 |
| - GB - | Operating manual | 35 |
| - F - | Mode d'emploi | 66 |
| - E - | Manual de instrucciones | 98 |

Translation of the original operating instructions

WARNING!

Attention, danger of injury by injection!

Airless units develop extremely high spray pressures.

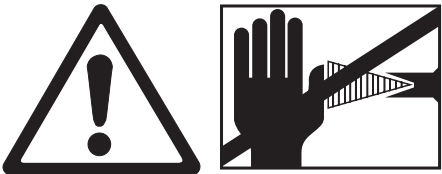
| | |
|----------|--|
| |  <p>Danger</p> |
| <p>①</p> | <p>Never bring fingers, hands or other body parts into contact with the spray jet! Never point the spray gun at yourself, other persons or animals. Never use the spray gun without spray jet safety guard.</p> <p>Do not treat a spray injury as a harmless cut. In case of injury to the skin by coating material or solvents, consult a doctor for quick and correct treatment. Inform the doctor about the coating material or solvent used.</p> |
| <p>②</p> | <p>The following points are to be observed in accordance with the operating manual before every start-up:</p> <ol style="list-style-type: none"> 1. Faulty units may not be used. 2. Secure a Wagner spray gun with the securing lever at the trigger guard. 3. Ensure earthing. 4. Check the permissible operating pressure of the high-pressure hose and spray gun. 5. Check all the connecting parts for leaks. |
| <p>③</p> | <p>Instructions for regular cleaning and maintenance of the unit are to be observed strictly.</p> <p>Observe the following rules before any work on the unit and at every working break:</p> <ol style="list-style-type: none"> 1. Relieve the pressure from the spray gun and high-pressure hose. 2. Secure a Wagner spray gun with the securing lever at the trigger guard 3. Switch the unit off. |

Ensure safety!

Contents

| | | | | | |
|-----------|--|-----------|-----------|--|-----------|
| 1 | SAFETY REGULATIONS FOR AIRLESS SPRAYING | 37 | | | |
| 1.1 | Flash point | 37 | 4.6 | Ventilate unit (hydraulic system) if the sound of inlet valve is not audible | 44 |
| 1.2 | Explosion protection | 37 | 4.7 | Taking the unit into operation with coating material | 44 |
| 1.3 | Danger of explosion and fire from sources of ignition during spraying work | 37 | 5 | SPRAYING TECHNOLOGY | 45 |
| 1.4 | Danger of injury from the spray jet | 37 | 6 | HANDLING THE HIGH-PRESSURE HOSE | 46 |
| 1.5 | Secure spray gun against unintended operation | 37 | 7 | INTERRUPTION OF WORK | 46 |
| 1.6 | Recoil of spray gun | 37 | 8 | CLEANING THE UNIT | 47 |
| 1.7 | Breathing equipment as protection against solvent vapors | 37 | 8.1 | Cleaning the unit from the outside | 48 |
| 1.8 | Prevention of occupational illnesses | 37 | 8.2 | Suction filter | 48 |
| 1.9 | Max. operating pressure | 38 | 8.3 | High-pressure filter | 48 |
| 1.10 | High-pressure hose | 38 | 8.4 | Cleaning the Airless spray gun | 49 |
| 1.11 | Electrostatic charging (formation of sparks or flames) | 38 | 9 | SERVICING | 49 |
| 1.12 | Use of units on building sites and workshops | 38 | 9.1 | General servicing | 49 |
| 1.13 | Ventilation when spraying in rooms | 38 | 9.2 | High-pressure hose | 49 |
| 1.14 | Suction installations | 38 | 10 | REPAIRS AT THE UNIT | 50 |
| 1.15 | Earthing of the object | 38 | 10.1 | Inlet valve | 50 |
| 1.16 | Cleaning the unit with solvents | 38 | 10.2 | Outlet valve | 51 |
| 1.17 | Cleaning the unit | 38 | 10.3 | Pressure control valve | 51 |
| 1.18 | Work or repairs at the electrical equipment | 38 | 10.4 | Replacing the power cable | 52 |
| 1.19 | Work at electrical components | 38 | 10.5 | Typical wear parts | 52 |
| 1.20 | Setup on an uneven surface | 38 | 10.6 | Connection diagram | 53 |
| 2 | GENERAL VIEW OF APPLICATION | 39 | 10.7 | Remedy in case of faults | 54 |
| 2.1 | Application | 39 | 11 | SPARE PARTS AND ACCESSORIES | 55 |
| 2.2 | Coating material | 39 | 11.1 | Super Finish 23 Pro accessories | 55 |
| 2.2.1 | Coating materials with sharp-edged additional materials | 39 | 11.2 | Spare parts list Super Finish 23 Pro | 60 |
| 2.2.2 | Filtering | 40 | 11.3 | Spare parts list high-pressure filter | 62 |
| 3. | DESCRIPTION OF UNIT | 40 | 11.4 | Spare parts list hopper | 62 |
| 3.1 | Airless process | 40 | 11.5 | Spare parts List Trolley | 63 |
| 3.2 | Functioning of the unit | 40 | 11.6 | Spare parts list suction system | 63 |
| 3.3 | Explanatory diagram | 41 | | Testing of the unit | 64 |
| 3.4 | Adjusting the handle | 42 | | Important information on product liability | 64 |
| 3.5 | Technical data | 42 | | Note on disposal | 64 |
| 4 | STARTUP | 43 | | Guarantee declaration | 64 |
| 4.1 | Unit with suction system | 43 | | CE - declaration | 65 |
| 4.2 | Unit with upper hopper | 43 | | European service network | 132 |
| 4.3 | High pressure hose and spray gun | 43 | | | |
| 4.4 | Connection to the mains network | 43 | | | |
| 4.5 | Cleaning preserving agent when starting-up of operation initially | 44 | | | |

1 SAFETY REGULATIONS FOR AIRLESS SPRAYING

All local safety regulations in force must be observed. The following sources are just a sample of those containing safety requirements for Airless spraying.

- a) The European Standard „Spray equipment for coating materials – safety regulations„ (EN 1953).

The following safety regulations are to be observed in order to ensure safe handling of the Airless high-pressure spraying unit.

1.1 FLASH POINT

| | |
|--|---|
|  Danger | <p>Only spray coating materials with a flash point of 21 °C or higher. The flash point is the lowest temperature at which vapors develop from the coating material. These vapors are sufficient to form an inflammable mixture over the air above the coating material.</p> |
|--|---|



1.2 EXPLOSION PROTECTION

| | |
|--|---|
|  Danger | <p>Do not use the unit in work places which are covered by the explosion protection regulations. The unit is not designed to be explosion protected. Do not operate the device in explosive areas (zone 0, 1 and 2). Explosive areas are, for example, places where paints are stored and locations in direct proximity to the object being sprayed. Keep the device at least 3 m from the object you are spraying.</p> |
|--|---|

1.3 DANGER OF EXPLOSION AND FIRE FROM SOURCES OF IGNITION DURING SPRAYING WORK

| | |
|--|---|
|  Danger | <p>There must be no sources of ignition such as, for example, open fires, lit cigarettes, cigars or tobacco pipes, sparks, glowing wires, hot surfaces, etc. in the vicinity.</p> |
|--|---|

1.4 DANGER OF INJURY FROM THE SPRAY JET

| | |
|--|--|
|  Danger | <p>Attention, danger of injury by injection! Never point the spray gun at yourself, other persons or animals. Never use the spray gun without spray jet safety guard. The spray jet must not come into contact with any part of the body. In working with Airless spray guns, the high spray pressures arising can cause very dangerous injuries. If contact is made with the spray jet, coating material can be injected into the skin. Do not treat a spray injury as a harmless cut. In case of injury to the skin by coating material or solvents, consult a doctor for quick and correct treatment. Inform the doctor about the coating material or solvent used.</p> |
|  | |

1.5 SECURE SPRAY GUN AGAINST UNINTENDED OPERATION

Always secure the spray gun when mounting or dismounting the tip and in case of interruption to work.

1.6 RECOIL OF SPRAY GUN

| | |
|--|---|
|  Danger | <p>When using a high operating pressure, pulling the trigger guard can effect a recoil force up to 15 N. If you are not prepared for this, your hand can be thrust backwards or your balance lost. This can lead to injury.</p> |
|--|---|

1.7 BREATHING EQUIPMENT AS PROTECTION AGAINST SOLVENT VAPORS

Wear breathing equipment during spraying work. A breathing mask is to be made available to the user.

1.8 PREVENTION OF OCCUPATIONAL ILLNESSES

Protective clothing, gloves and possibly skin protection cream are necessary for the protection of the skin.

Observe the regulations of the manufacturer concerning coating materials, solvents and cleaning agents in preparation, processing and cleaning units.

1.9 MAX. OPERATING PRESSURE

The permissible operating pressure for the spray gun, spray gun accessories, unit accessories and high-pressure hose must not fall short of the maximum operating pressure of 25 MPa (250 bar or 3625 psi).

1.10 HIGH-PRESSURE HOSE

| | |
|---|--|
|  Danger | <p>Attention, danger of injury by injection! Wear and tear and kinks as well as usage that is not appropriate to the purpose of the device can cause leakages to form in the high-pressure hose. Liquid can be injected into the skin through a leakage.</p> |
|---|--|

- High-pressure hoses must be checked thoroughly before they are used.
- Replace any damaged high-pressure hose immediately.
- Never repair defective high-pressure hoses yourself!
- Avoid sharp bends and folds: the smallest bending radius is about 20 cm.
- Do **not drive over** the high-pressure hose. Protect against sharp objects and edges.
- Never pull on the high-pressure hose to move the device.
- Do not twist the high-pressure hose.
- Do not put the high-pressure hose into solvents. Use only a wet cloth to wipe down the outside of the hose.
- Lay the high-pressure hose in such a way as to ensure that it cannot be tripped over.

| | |
|--|--|
|  | <p>Only use WAGNER original-high-pressure hoses in order to ensure functionality, safety and durability.</p> |
|--|--|

1.11 ELECTROSTATIC CHARGING (FORMATION OF SPARKS OR FLAMES)

| | |
|---|--|
|  Danger | <p>Electrostatic charging of the unit may occur during spraying due to the flow speed of the coating material. These can cause sparks and flames upon discharge. The unit must therefore always be earthed via the electrical system. The unit must be connected to an appropriately-grounded safety outlet.</p> |
|---|--|

An electrostatic charging of spray guns and the high-pressure hose is discharged through the high-pressure hose. For this reason the electric resistance between the connections of the high-pressure hose must be equal to or lower than 1 MΩ.

1.12 USE OF UNITS ON BUILDING SITES AND WORKSHOPS

The unit may only be connected to the mains network via a special feeding point with a residual-current device with INF ≤ 30 mA.

1.13 VENTILATION WHEN SPRAYING IN ROOMS

Adequate ventilation to ensure removal of the solvent vapors has to be ensured.

1.14 SUCTION INSTALLATIONS

The are to be provided by the unit user in accordance with the corresponding local regulations.

1.15 EARTHING OF THE OBJECT

The object to be coated must be earthed.
(Building walls are usually earthed naturally)

1.16 CLEANING THE UNIT WITH SOLVENTS

| | |
|--|--|
|  Danger | <p>When cleaning the unit with solvents, the solvent should never be sprayed or pumped back into a container with a small opening (bunghole). An explosive gas/air mixture can arise. The container must be earthed.</p> |
|--|--|

1.17 CLEANING THE UNIT

| | |
|--|--|
|  Danger | <p>Danger of short-circuits caused by water ingress! Never spray down the unit with high-pressure or high-pressure steam cleaners.</p> |
|--|--|

1.18 WORK OR REPAIRS AT THE ELECTRICAL EQUIPMENT

These may only be carried out by a skilled electrician. No liability is assumed for incorrect installation.

1.19 WORK AT ELECTRICAL COMPONENTS

Unplug the power plug from the outlet before carrying out any repair work.

1.20 SETUP ON AN UNEVEN SURFACE

The front end must always point downwards in order to avoid sliding away.

If possible do not use the unit on an inclined surface since the unit tends to wander through the resulting vibrations.

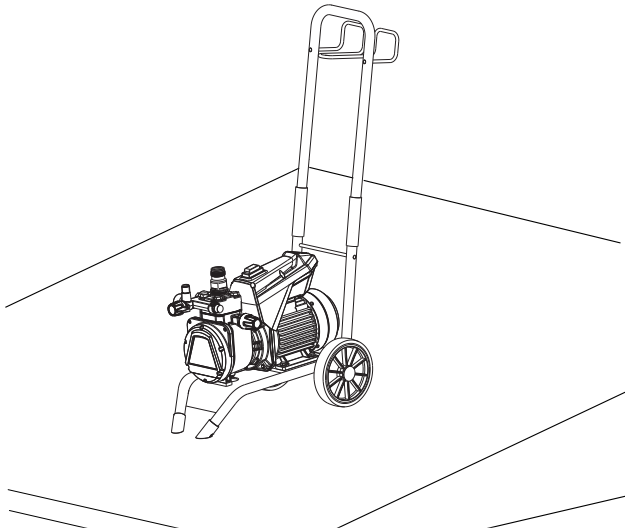

2 GENERAL VIEW OF APPLICATION

2.1 APPLICATION

SF 23 Pro is an electric driven unit for the airless atomization of different painting materials. Also it is able to feed the internal feeded paint roller, which is available as accessory.

SF 23 Pro is made for jobs in the workshop and on the building site.

The SF 23 Pro's device output is designed so that dispersions can be processed indoors and outdoors for small to medium-sized objects.

When painting, the device is suitable for all kinds of typical painting jobs, e.g.:

doors, door frames, balustrades, furniture, woodencladding, fences, radiators (heating) and steel parts.

We recommend using the top container for paintwork.

2.2 COATING MATERIAL

Diluting lacquers and paints or those containing solvents, two-component coating materials, dispersion and latex paints.

No other materials should be used for spraying without WAGNER's approval.



Pay attention to the Airless quality of the coating materials to be processed.

The unit is able to process coating materials with up to 20,000 mPas. If highly viscous coating materials cannot be taken in or the performance of the unit is too low, the paint must be diluted in accordance with the manufacturer's instructions.



Attention: Make sure, when stirring up with motor-driven agitators that no air bubbles are stirred in. Air bubbles disturb when spraying and can, in fact, lead to interruption of operation.

2.2.1 COATING MATERIALS WITH SHARP-EDGED ADDITIONAL MATERIALS

These particles have a strong wear and tear effect on valves and tips, but also on the heating hose and spray gun. This impairs the durability of these wearing parts considerably.

GENERAL VIEW OF APPLICATION

2.2.2 FILTERING

Sufficient filtering is required for fault-free operation. To this purpose the unit is equipped with a suction filter (Item 1) and an insertion filter in the spray gun (Item 2). Regular inspection of these filters for damage or soiling is urgently recommended.

A high-pressure filter (Item 3) -available as accessory- is rising up the filtering surface and will make the work more comfortable.

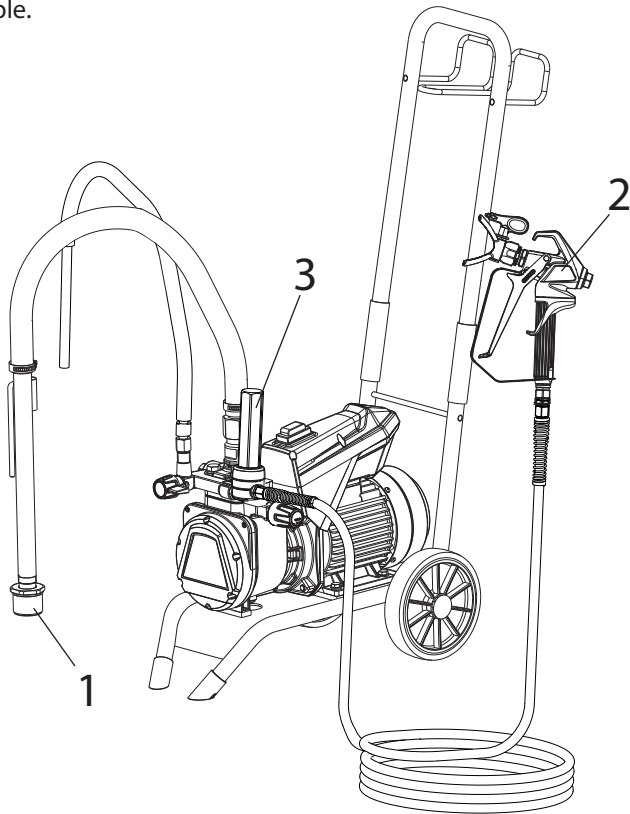

3. DESCRIPTION OF UNIT

3.1 AIRLESS PROCESS

The main area of application are thick layers of highly viscous coating material.

At the SF 23 Pro unit a diaphragm pump takes in the coating materials and transports it via a high-pressure hose to the spray gun with the airless tip. Here the coating material atomizes since it is pressed through the tip core at a maximum pressure of 25 MPa (250 bar, 3625 psi). This high pressure has the effect of micro fine atomisation of the coating material. As no air is used in this process, it is described as an AIRLESS process.

This method of spraying has the advantages of finest atomisation, cloudless operation (depending of a correct unit adjustment) and a smooth, bubblefree surface. As well as these, the advantages of the speed of work and convenience must be mentioned.

3.2 FUNCTIONING OF THE UNIT

The following section contains a brief description of the technical construction for better understanding of the function:

SF 23 Pro is an electrically driven high-pressure paint spraying equipment.

The electric motor (1) drives the hydraulic pump via planetary gears (2). A piston (3) is moved up and down so that hydraulic oil is moved under the diaphragm (4) which then moves.

In detail:

The downwards movement of the machine opens the disk inlet valve (5) automatically and coating material is sucked in. During the upwards movement of the diaphragm, the coating material is displaced and the outlet valve opens while the inlet valve is closed.

The coating material flows under high pressure through the high-pressure hose to the spray gun and is atomized when it exists from the tip.

The pressure control valve limits the set pressure in the hydraulic oil circuit and thus also the pressure of the coating material.

A pressure change when the same tip is used also leads to a change in the amount of paint atomized.

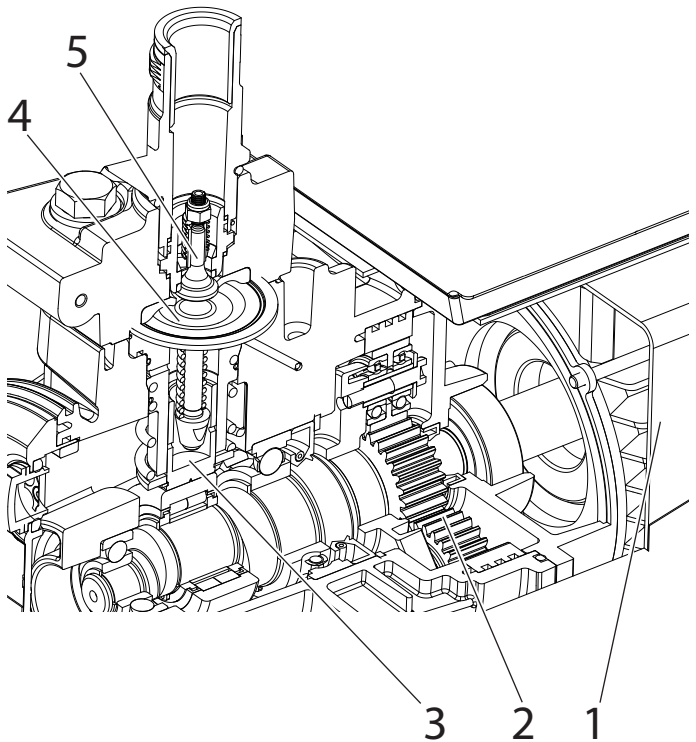

DESCRIPTION OF UNIT

3.4 ADJUSTING THE HANDLE

Swing the handle (1) upwards (the sleeves fall downwards and secure the handle in the terminal position).

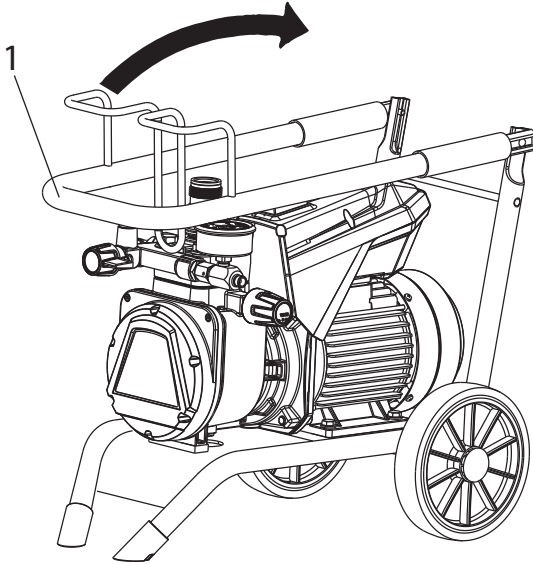

Push the sleeves (2) upwards in order to swing the handle down again if necessary.

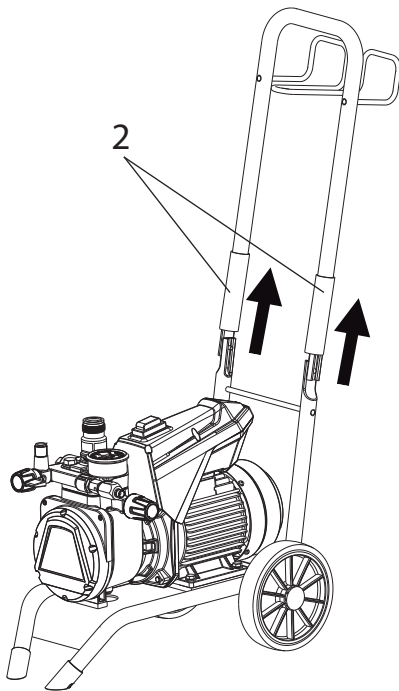
**Transportation in vehicle**

Secure the unit in the vehicle by means of suitable fasteners. The device can be placed on its side if necessary. In this case, please ensure that no attachments can be damaged. Attention: Paint or solvent residues can escape from the connections!

3.5 TECHNICAL DATA

| | |
|--|-----------------------------------|
| Voltage : | 230 -240 V AC, 50 Hz |
| Fuses : | 16 A time-lag |
| Unit connecting line : | 6 m long, 3 x 1.5 mm ² |
| Max. current consumption: | 7.0 A |
| Degree of protection : | IP 54 |
| Rated input of device: | 1.3 kW |
| Max. operating pressure : | 25 MPa (250 bar) |
| Max. volume flow : | 2.6 l/min |
| Volume flow at 12 MPa (120 bar) with water : | 2.3 l/min |
| Max. temperature of the coating material : | 43 °C |
| Max. viscosity : | 20,000 mPas |
| Empty weight : | 27 kg |
| Hydraulic oil filling quantity : | |
| Hydraulics housing | 1.3 liter |
| Gears (grease) | 45 g |
| Max. vibration at the spraygun : | lower than 2.5 m/s ² |
| Max. sound pressure level: | 75 dB (A)* |

*Place of measurement: 1 m distance from unit and 1.60 m above floor, 12 MPa (120 bar) operating pressure, reverberant floor

4 STARTUP

| | |
|---|--|
|  | <p>Press the inlet valve inside the coating material inlet (4) downwards before starting the operation. This ensures that the valve is not blocked or clogged.</p> |
|---|--|

4.1 UNIT WITH SUCTION SYSTEM

1. Ensure that the sealing surfaces of the connections are clean. Ensure that the red inlet (1) is inserted in the coating material inlet (4).
2. Use the enclosed 41 mm wrench to screw the union nut (2) at the suction hose (3) onto the coating material inlet (4) and tighten it.
3. Screw the union nut (5) at the return hose (6) to the connection (7) (22mm).

4.2 UNIT WITH UPPER HOPPER

1. Ensure that the sealing surfaces of the connections are clean. Ensure that the red inlet (1) is inserted in the coating material inlet (4).
2. Screw the union nut (5) on the return pipe (6) onto the connection (7).
3. Screw the upper hopper (8) onto the coating material inlet (4).

4.3 HIGH PRESSURE HOSE AND SPRAY GUN

1. Screw the high pressure hose (9) onto the hose connection
2. Screw the spray gun (10) onto the high pressure hose
3. Tighten all union nuts on high pressure hose so that no coating material can escape.
4. Screw the tip holder with the selected tip onto the spray gun, align tip and tighten union nut.

| | |
|---|---|
|  <p>Attention</p> | <p>When unscrewing the high pressure hose, hold firmly on the hose connection with a 22mm wrench.</p> |
|---|---|

4.4 CONNECTION TO THE MAINS NETWORK

| | |
|---|--|
|  <p>Attention</p> | <p>Connection must always be carried out via an appropriately grounded safety outlet with residual-current-operated circuit-breaker.</p> |
|---|--|

Before connecting the unit to the mains supply, ensure that the line voltage matches that specified on the unit's rating plate.

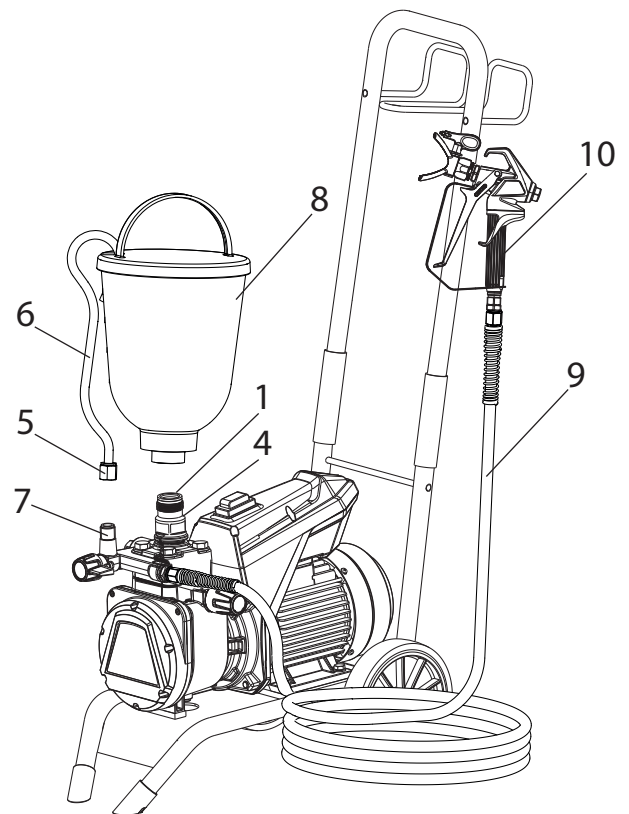
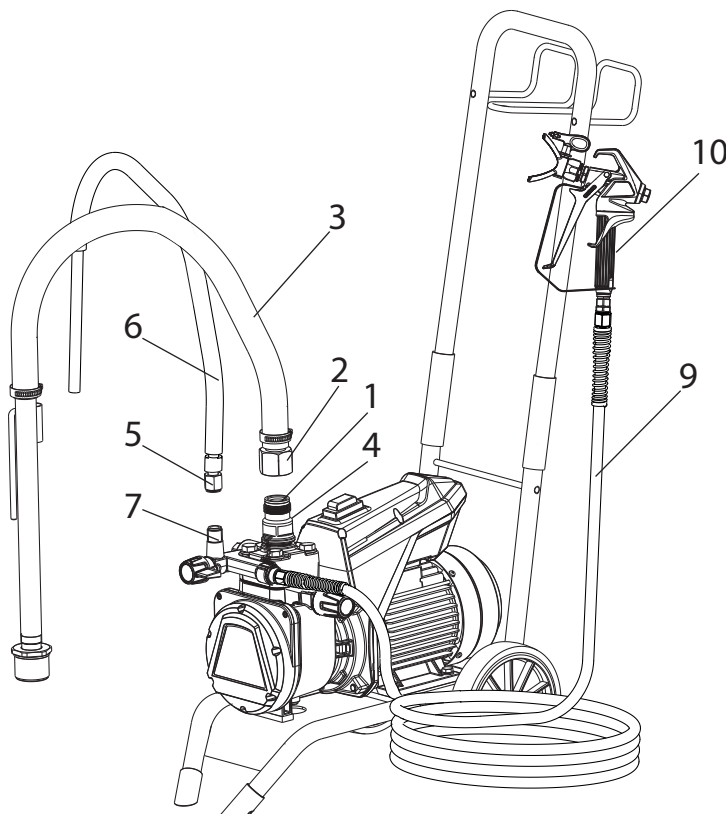



4.5 CLEANING PRESERVING AGENT WHEN STARTING-UP OF OPERATION INITIALLY

Unit with suction tube

1. Immerse the suction system into a container filled with a suitable cleaning agent (recommendation: water).

Unit with hopper

2. Fill up hopper with a suitable cleaning agent (recommendation: water).
3. Set pressure relief valve (1) to  (circulation).
4. Switch the device on (Pos. I) using the ON/OFF switch (2).
5. Slowly turn the pressure regulating knob (3) to the **right**.
6. Wait until you can hear the sound of the inlet valve and cleaning agent flows from the return hose.
7. Turn the pressure regulating knob (3) back approx. one rotation.
8. Set pressure relief valve (1) to  (spray). Pressure is rising up inside the high pressure hose (visible at pressure gauge (4)).
9. Point the tip of the spray gun to inner wall of an open and empty metal container and pull the trigger at the spray gun.
10. The pressure is increased by turning the pressure regulating knob (3) to the right. Set approx. 10 MPa (100 bar) at the pressure gauge.
11. Spray the cleaning agent out of the unit for approx. 1 - 2 min. (~5 litres) into the open collecting container.

4.6 VENTILATE UNIT (HYDRAULIC SYSTEM) IF THE SOUND OF INLET VALVE IS NOT AUDIBLE

1. Switch the device on (Pos. I) using the ON/OFF switch (2).
2. Turn pressure regulating knob (3) **approx. three revolutions** to the **left**.
3. Set pressure relief valve (1) to  (circulation). The hydraulic system is ventilated. Leave the unit on for two to three minutes.
4. Then slowly turn pressure regulating knob (3) to the **right** until you can hear the sound of the inlet valve.
5. If not, repeat points 2 and 4

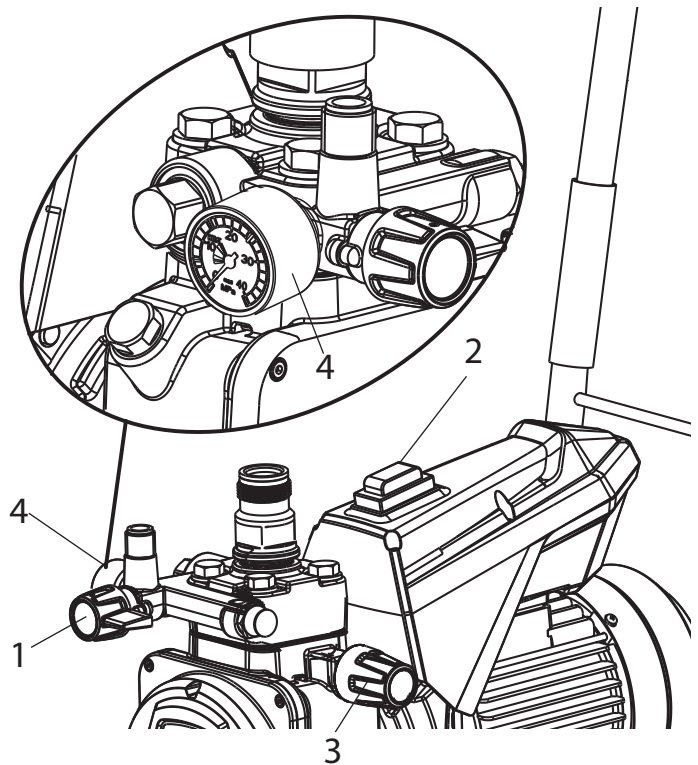



4.7 TAKING THE UNIT INTO OPERATION WITH COATING MATERIAL

Unit with suction tube

1. Immerse the suction system into a container filled with coating material.

Unit with hopper

2. Fill coating material into the hopper.
3. Set pressure relief valve (1) to  (circulation).
4. Switch the device on (Pos. I) using the ON/OFF switch (2).
5. Slowly turn the pressure regulating knob (3) to the **right**. When the noise of the valves changes, the unit is bled and takes in coating material.
6. If coating material exits from the return hose, turn the pressure regulating knob (3) back approx. 1 rotation.
7. Set pressure relief valve (1) to  (spray). Pressure is rising up inside the high pressure hose (visible at pressure gauge (4)).
8. Pull the trigger of the spray gun and spray into an open and empty container in order to remove the remaining cleaning agent from the unit. When coating materials exits from the tip, close the spray gun.
9. Adjust the spraying pressure by turning the pressure regulating knob (3).
10. The unit is ready to spray.

5 SPRAYING TECHNIQUE

- The key to a high-quality result is the even coating of the entire surface. Move your arm at a uniform speed and hold the spray gun at a constant distance from the surface. The ideal distance is around 30 cm between the spray nozzle and the surface. (Fig. A)
- Hold the spray gun parallel to the surface. Move the gun using your entire arm, not just the wrist. (Fig. B)
- Hold the spray gun at right angles to the surface. Otherwise the coating will be thicker at one end than the other. (Fig. C)
- Pull the trigger guard once you have started the movement. Release the trigger again before you finish the movement. (Fig. D) Avoid interruptions within the spray surface.
- Allow each stripe to overlap by around 30%. This will ensure even coating. (Fig. E)
- Use the lowest possible pressure setting to create the desired spray pattern in order to minimise spray mist.
- To achieve perfect surfaces at varnishing works, special accessories are available at Wagner, e.g. FineFinish tips. Your Wagner dealer will advise you.

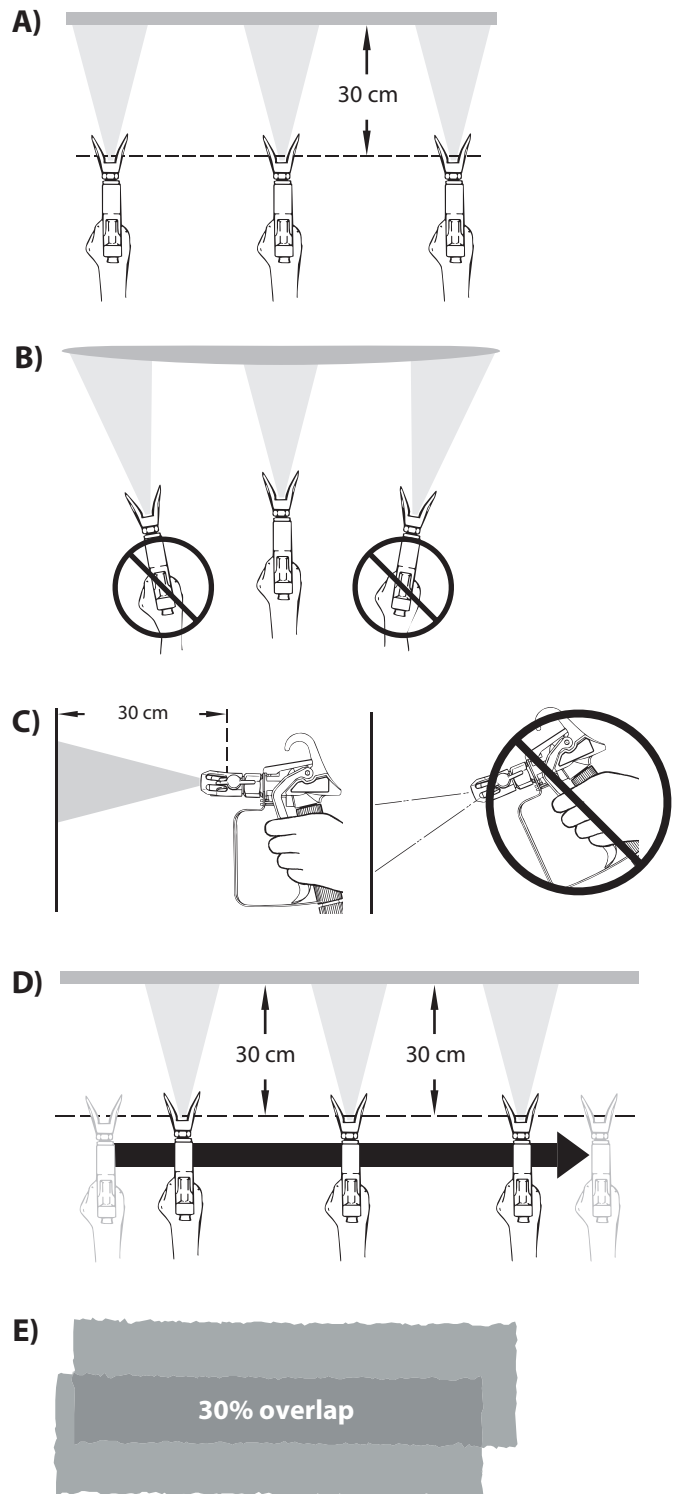

6 HANDLING THE HIGH-PRESSURE HOSE

The unit is equipped with a high-pressure hose specially suited for diaphragm pumps.

| | |
|---|--|
|  Danger | <p>Danger of injury through leaking high-pressure hose. Replace any damaged high-pressure hose immediately. Never repair defective high-pressure hoses yourself!</p> |
|---|--|

The high-pressure hose is to be handled with care. Avoid sharp bends and folds: the smallest bending radius is about 20 cm. Do **not drive over** the high-pressure hose. Protect against sharp objects and edges.

Never pull on the high-pressure hose to move the device.

Make sure that the high-pressure hose cannot twist. This can be avoided by using a Wagner spray gun with a swivel joint and a hose system.

| | |
|--|---|
|  | <p>When using the high-pressure hose while working on scaffolding, it is best to always guide the hose along the outside of the scaffolding.</p> |
|--|---|

| | |
|---|--|
|  | <p>The risk of damage rises with the age of the high-pressure hose. Wagner recommends replacing high-pressure hoses after 6 years.</p> |
|---|--|

| | |
|---|--|
|  | <p>Only use WAGNER original-high-pressure hoses with internal heating in order to ensure functionality, safety and durability.</p> |
|---|--|

7 INTERRUPTION OF WORK

1. Set pressure relief valve to  (pressure relief, circulation).
2. Switch the unit off using the ON/OFF switch (Pos. 0).
3. Pull trigger of the spray gun to decrease the pressure of the high pressure hose and the spray gun.
3. Secure the spray gun, refer to the operating manual of the spray gun.
4. Remove tip from tip holder and store the tip in a small vessel with suitable cleaning agent.
5. Leave the suction system immersed in the coating material or immerse it in the corresponding cleaning agent. The suction filter and unit should not dry out.
6. Cover the material container in order to prevent the paint from drying.

| | |
|---|---|
|  | <p>In using quick-drying or two-component coating materials, do not fail to rinse unit through with a suitable cleaning agent during the processing period.</p> |
|---|---|

8 CLEANING THE UNIT

A clean state is the best method of ensuring operation without problems. After you have finished spraying, clean the unit. Under no circumstances may coating material rests dry and harden in the unit. The cleaning agent used for cleaning (only with a flash point above 21 °C) must be suitable for the coating material used.

| | |
|--|---|
| | Warm water improves the cleaning effect in the case of water-dilutable coating materials. |
|--|---|

- **Secure the spray gun**, refer to the operating manual of the spray gun.

Remove and clean the tip and tip holder.

- **Unit with suction system**

1. Set pressure relief valve to (circulation).
2. Switch the device on (Pos. I) using the ON/OFF switch.
3. Remove the suction system from the material container. The return pipe hose remains over the material container until barely any coating material comes out.
4. Immerse the suction system into a container filled with a suitable cleaning agent
5. Turn the pressure control valve back in order to set a minimal spraying pressure.
6. Set pressure relief valve to (spray).
7. Pull the trigger of the spray gun in order to pump the remaining coating material from the suction hose, high-pressure hose and the spray gun into an open container (if appropriate, increase the pressure at the pressure control valve slowly in order to obtain a higher material flow).

| | |
|--|--|
| | The container must be earthed in case of coating materials which contain solvents (e.g. by using a metal container). |
|--|--|

| | |
|--|---|
| | Caution! Do not pump or spray in container with small opening (bunghole)! See safety regulations. |
|--|---|

8. Set pressure relief valve to (circulation).
9. Pump suitable cleaning agent in the circuit for several minutes.

| | |
|--|--|
| | The cleaning effect is increased by alternatively opening and closing the spray gun. |
|--|--|

10. Set pressure relief valve to (spray).
11. Pump the remaining cleaning agent into an open container until the pump is empty.
12. Set pressure relief valve to (circulation).
13. Switch the unit off using the ON/OFF switch (Pos. 0).

- **Unit with upper hopper**

1. Set pressure relief valve to (circulation).
2. Switch the device on (Pos. I) using the ON/OFF switch.
3. Turn the pressure control valve back in order to set a minimal spraying pressure.
4. Set pressure relief valve to (spray).
5. Pull the trigger of the spray gun in order to pump the remaining coating material from the hopper, high-pressure hose and the spray gun into an open container (if appropriate, increase the pressure at the pressure control valve slowly in order to obtain a higher material flow).

| | |
|--|--|
| | The container must be earthed in case of coating materials which contain solvents (e.g. by using a metal container). |
|--|--|

| | |
|--|---|
| | Caution! Do not pump or spray in container with small opening (bunghole)! See safety regulations. |
|--|---|

6. Fill up hopper with suitable cleaning agent.
7. Set pressure relief valve to (circulation).
8. Pump suitable cleaning agent in the circuit for several minutes.
9. Set pressure relief valve to (spray).
10. Pump the remaining cleaning agent from the hopper, high-pressure hose and the spray gun into an open container
11. Set pressure relief valve to (circulation).
12. Switch the unit off using the ON/OFF switch (Pos. 0).

CLEANING THE UNIT

8.1 CLEANING THE UNIT FROM THE OUTSIDE

| | |
|-------------------|--|
| Danger | <p>First unplug the power plug from the outlet.</p> <p>Danger of short-circuits caused by water ingress! Never spray down the unit with high-pressure or high-pressure steam cleaners.</p> |
|-------------------|--|

| | |
|-------------------|--|
| Danger | <p>Do not put the high-pressure hose into solvents. Use only a wet cloth to wipe down the outside of the hose.</p> |
|-------------------|--|

Wipe down unit externally with a cloth which has been immersed in a suitable cleaning agent.

8.2 SUCTION FILTER

| | |
|--|--|
| | <p>Clean filters always ensure maximum volume, constant spray pressure and problem-free functioning of the unit.</p> |
|--|--|

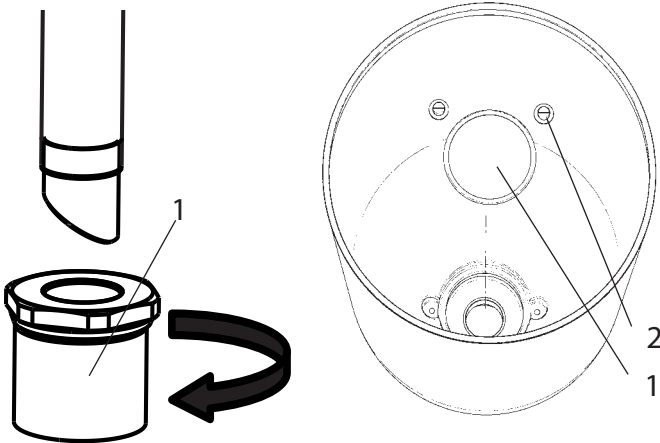

suction system

hopper

Unit with suction system

1. Unscrew the filter (Item 1) from the suction tube.
2. Clean or replace the filter.
Carry out cleaning with a hard brush and a corresponding cleaning agent.

Unit with hopper

1. Release screws with a screwdriver (Item 2).
2. Lift and remove filter disk with a screwdriver
3. Clean or replace the filter disk.
Carry out cleaning with a hard brush and a corresponding cleaning agent.

8.3 HIGH-PRESSURE FILTER

1. Set pressure relief valve to (pressure relief, circulation).
2. Switch the unit off using the ON/OFF switch (Pos. 0).
3. Open the high-pressure filter and clean the filter insert. To do so:
4. Unscrew the filter housing (1) by hand.
5. Remove the filter insert (2) and pull out the bearing spring (3).
6. Clean all the parts with the corresponding cleaning agent. If compressed air is available – blow through the filter insert and bearing spring.
7. When mounting the filter ensure that the bearing ring (4) in the filter insert is positioned correctly and check the O-ring at the filter housing for damage.
8. Screw on the filter housing by hand until it stops (a higher tightening force only impedes later dismantling).

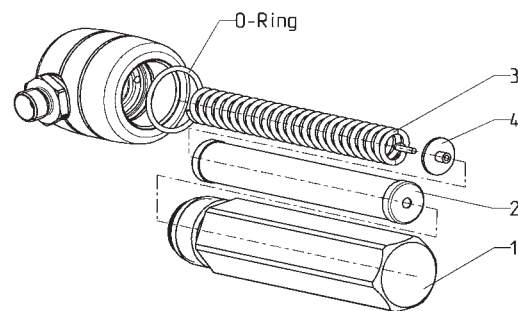

8.4 CLEANING THE AIRLESS SPRAY GUN

1. Rinse the Airless spray gun with a suitable cleaning agent under lower operating pressure.
2. Clean the tip thoroughly with a suitable cleaning agent so that no suitable coating material rests remain.
3. Do not store the tip in solvent because this reduces the durability considerably.
4. Clean the outside of the Airless spray gun thoroughly.

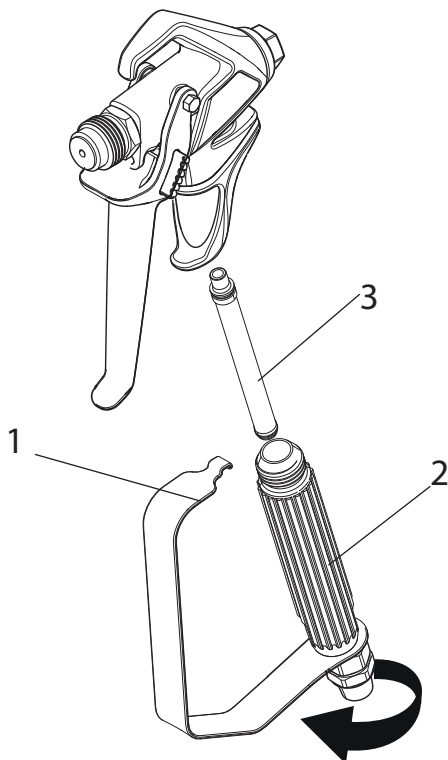

Insertion filter in the Airless spray gun

1. Unclip the top of the trigger guard (1) from the gun head.
2. Using the bottom of the trigger guard as a wrench, loosen and remove the handle assembly (2) from the gun head.
3. Pull the old filter (3) out of the gun head. Clean or replace.
4. Slide the new filter, tapered end first, into the gun head.
5. Thread the handle assembly into the gun head. Tighten with the trigger wrench.
6. Snap the trigger guard back onto the gun head.

9 SERVICING

9.1 GENERAL SERVICING



We strongly recommend having an annual check carried out by technicians for safety reasons. Please observe all the applicable national regulations.

Minimum check before every startup:

1. Check the high-pressure hose, spray gun with rotary joint, power supply cable with plug for damage.
2. Check whether the pressure gauge can be read.

Check at periodical intervals:

1. Check inlet and outlet valve according wear. Clean it and replace worn out parts.
2. Check all filter inserts (spray gun, suction system) clean it and replace if necessary.

9.2 HIGH-PRESSURE HOSE

Inspect the high-pressure hose visually for any notches or bulges, in particular at the transition in the fittings. It must be possible to turn the union nuts freely. A conductivity of less than 1 MΩ must exist across the entire length.



Attention

Have all the electric tests carried by the Wagner Service.



The risk of damage rises with the age of the high-pressure hose. Wagner recommends replacing high-pressure hoses after 6 years.

10 REPAIRS AT THE UNIT



Danger

Switch the unit off.
Before all repair work: Unplug the power
plug from the outlet.

10.1 INLET VALVE

Disassembly

1. Place the enclosed 30 mm wrench on the housing (1).
2. Loosen the housing (1) with light blows of a hammer on the end of the wrench.
3. Screw out the housing with the inlet valve (2) from the paint section.
4. Pull off the clasp (3) using the enclosed screwdriver.
5. Place the enclosed 30 mm wrench on the inlet valve (2). Turn out the inlet valve carefully.
6. Clean the valve seat (4) with a cleaning agent and brush (ensure that no brush hairs are left behind).
7. Clean the seals (5, 6) and check for damage. Replace, if necessary.
8. Check all the valve parts for damage. In case of visible wear replace the inlet valve.

Installation

1. Insert the inlet valve (2) into the housing (1) and secure with the clasp (3). Ensure that the (black) seal (5) is mounted in the housing.
2. Screw the unit from the housing and the inlet valve into the paint section. The same (black) seal (6) has to be mounted in the paint section.
3. Tighten the housing with the 30 mm wrench and tighten with three light blows of the hammer on the end of the wrench. (Corresponds to approx. 90 Nm tightening torque).

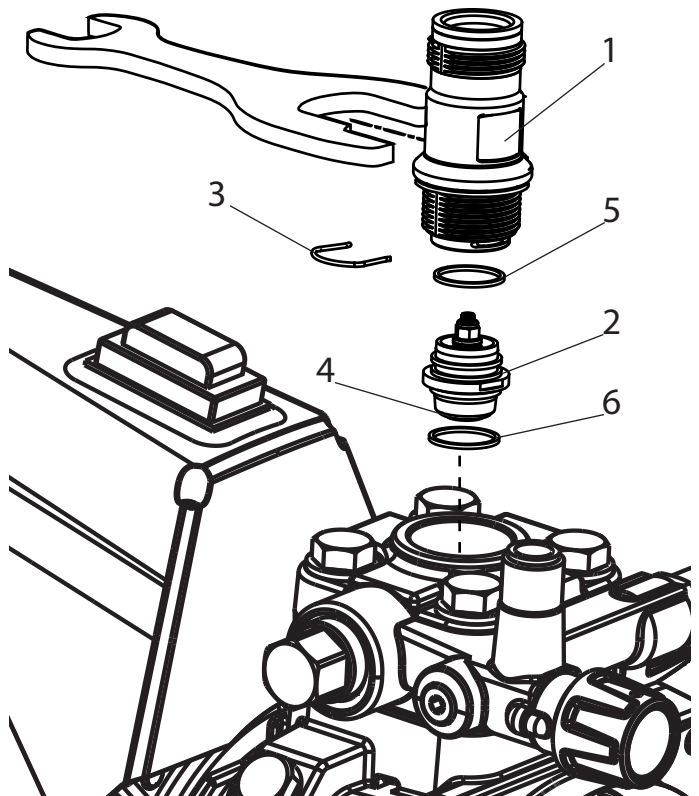

10.2 OUTLET VALVE

1. Use a 22 mm wrench to screw the outlet valve from the paint section.
2. Carefully remove the clasp (1) using the enclosed screwdriver. The pressure spring (2) pushes out ball (4) and valve seat (5).
3. Clean or replace the components.
4. Check the O-ring (7) for damage.
5. Check the installation position when mounting the spring support ring (3) (clipped onto spring (2)), outlet valve seat (5) and seal (6), refer to figure.

Please also pay particular attention to the following notes:

1. Use some light hammer blows on the end of the wrench (20mm) to fully tighten outlet valve in the paint section (this corresponds to approx. 50 Nm tightening torque).
2. During normal operation, check regularly whether the outlet valve has become loose.
3. Always also replace the seal (6) if you have dismantled the outlet valve, regardless of which component you want to replace. Note: The seal (6) is located inside the paint section.
4. The groove in the seal (6) points outwards when replaced.

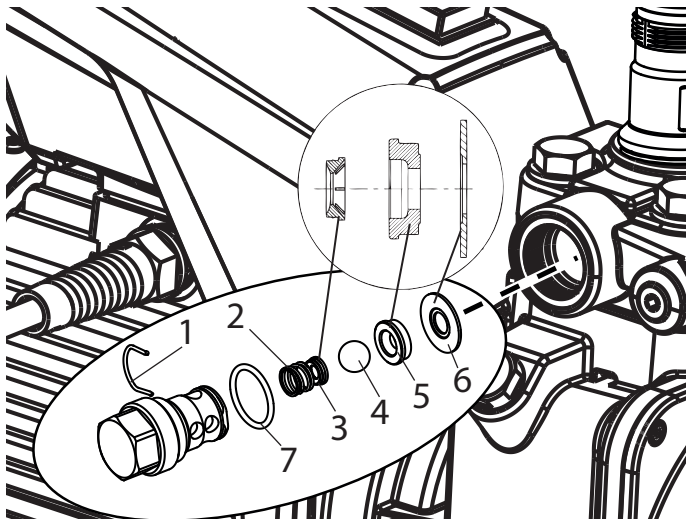

10.3 PRESSURE CONTROL VALVE



Only have the pressure control valve (1) replaced by the customer service. The max. operating pressure has to be reset by the customer service.

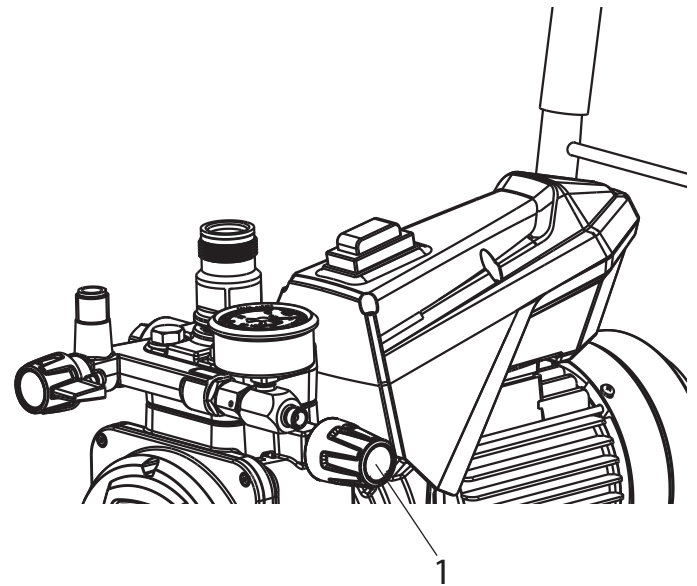

10.4 REPLACING THE POWER CABLE



This may only be carried out by a skilled electrician. No liability is assumed for incorrect installation.
Switch the unit off.
Before all repair work: Unplug the power plug from the outlet.

1. Remove the cover (1) by loosening the screws.
2. Loosen the cable threaded joint (2).
3. Loosen the wires (3).
4. Replace the unit connecting line.
(only an approved power cable with the designation H07-RNF with a splash-proof plug may be used).
5. Connect the green/yellow wire to the contact with the PE sign.
6. Remount the covers carefully (do not squeeze any cables!)

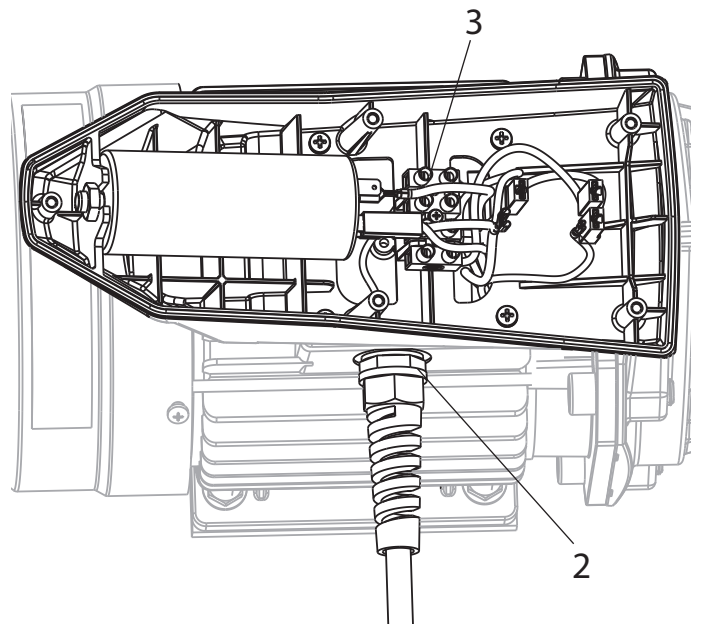
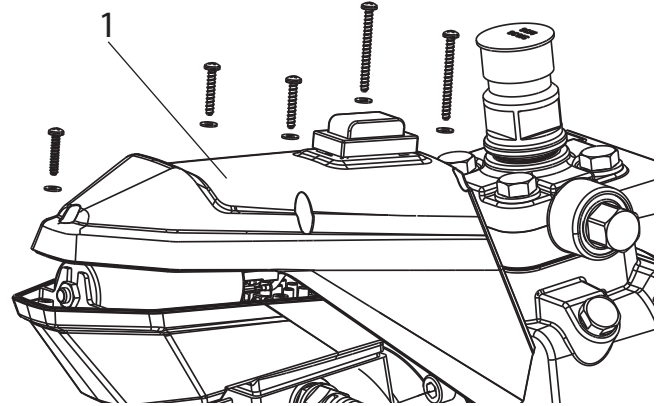

10.5 TYPICAL WEAR PARTS

Despite the use of high-quality materials the highly abrasive effect of the paints means that wear can occur at the following parts:

Inlet valve

For replacing refer to Section 10.1

(failure becomes noticeable through performance loss and/or poor or no suction)

Outlet valve

For replacing refer to Section 10.2

(failure becomes noticeable through performance loss and/or poor suction) The outlet valve is usually considerably more durable than the inlet valve. Thorough cleaning may already help here.

10.7 CONNECTION DIAGRAM

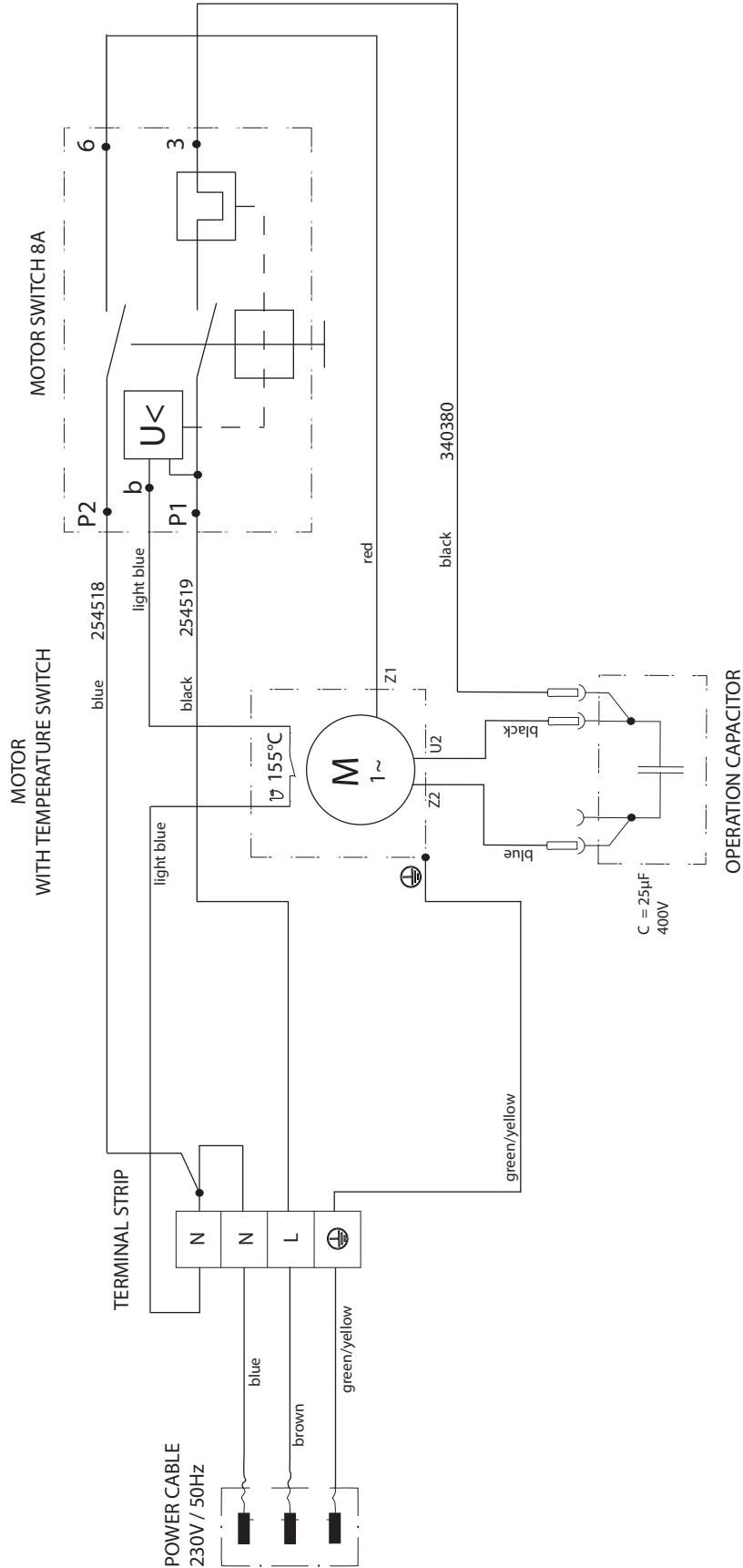

10.7 REMEDY IN CASE OF FAULTS

| TYPE OF MALFUNCTION | WHAT ELSE? | POSSIBLE CAUSE | MEASURES FOR ELIMINATING THE MALFUNCTION |
|---------------------------------|--|--|---|
| Unit does not start | The device does not start after it has been plugged in and switched on. | No voltage applied | Check voltage supply |
| | | Unit fuse has triggered | Let the motor cool down |
| | | Capacitor in terminal box burned out | Replace capacitor |
| Unit does not suck in | Air bubbles do not exit at the return hose | Inlet/outlet valve clogged / worn | Remove the valves and clean then (-> refer to Section Pkt.10.1/10.2) / replace worn parts |
| | | Pressure control valve turned down completely | Turn the pressure control valve to the right until the stop is reached |
| | Air bubbles exit from the return hose | Unit is sucking in outside air | Check if Suction system is properly tightened |
| | | | Check if red inlet is installed in the inlet valve housing (-> see 4.1) |
| | | Check if the inlet valve housing is tightened enough. | |
| Unit does not generate pressure | Unit has sucked in | Air in the oil circuit (Possible reasons: long time not used, replacement of diaphragm or hydraulic oil change) | Vent the hydraulic system (-> see 4.6) |
| | Unit reached pressure, but the pressure collapses, also at the pressure gauge, during spraying. | Suction filter clogged | Check the suction filter. If necessary, clean/replace |
| | | Paint cannot be worked in this state. Due to its properties the paint clogs the valves (inlet valve) and the delivery rate is too low. | Dilute the paint |
| | Unit reached pressure, but the pressure collapses during spraying. pressure gage still shows high pressure | Clogged filter do not let enough paint pass | Check/clean the (high-pressure filter) gun filter |
| | | Tip clogged | Clean the tip |
| | Unit does not generate the max. pressure possible. Paint nevertheless exits at the return hose. | Relief valve defective | Please contact Wager Customer Service |
| | After a longer period of time, the pressure drops or the performance of the suction tube decreases (although all connected filters are not blocked). | Inlet valve worn | Replace inlet valve |
| | | Outlet valve worn | Replace outlet valve |
| Tip worn | | Replace tip | |

11 SPARE PARTS AND ACCESSORIES

11.1 SUPER FINISH 23 PRO ACCESSORIES

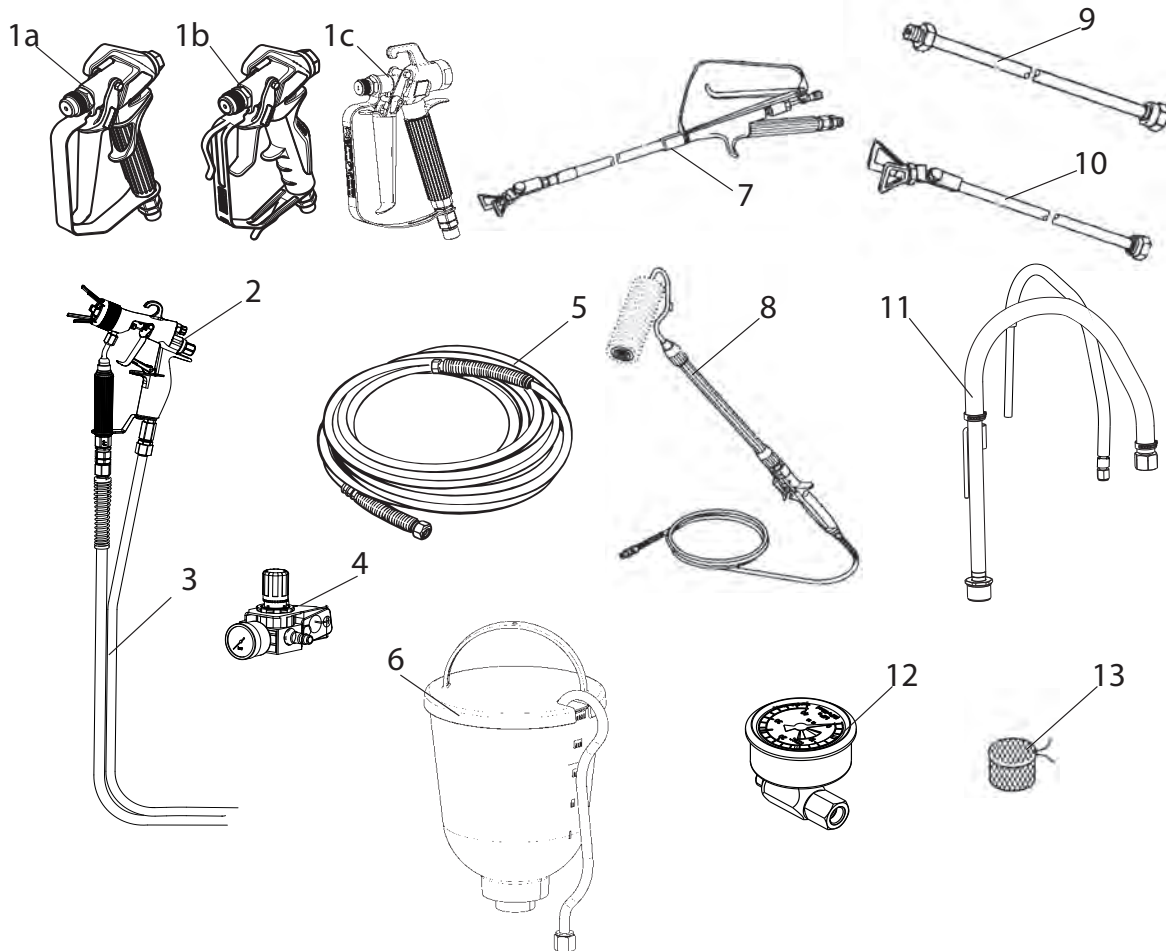

Accessories:

| ITEM | DESIGNATION | ORDER NO. |
|------|--|----------------------|
| 1a | Spray gun Vector Pro (2-finger) | 0538 041 |
| | Spray gun Vector Pro (4-finger) | 0538 040 |
| 1b | Spray gun Vector Pro (2-finger and 4-finger) | 0538 043 |
| 1c | Spray gun AG-14 (stainless steel) | 0502 166 |
| 2 | AirCoat spray gun AC 4500 (blue) | 2368 269 |
| 3 | Double hose | 9984 564 |
| 4 | AirCoat-controller set | 0340 250 |
| 5 | HP hose DN6-PN270-1/4"NPSM-15m | 9984 574 |
| 6 | Hopper 5l | 0341 265 |
| 7 | Pole gun Length 120cm; G thread 7/8" Length 200cm; G thread 7/8" | 0296 441 0296 442 |
| 8 | Inline Roller | 0345 010 |

| ITEM | DESIGNATION | ORDER NO. |
|------|---|--|
| 9 | Tip extension Length 15 cm Length 30 cm Length 45 cm Length 60 cm | 0556 051 0556 052 0556 053 0556 054 |
| 10 | Tip extension with Slewable knee joint Length 100 cm Length 200 cm Length 300 cm | 0096 015 0096 016 0096 017 |
| 11 | Suction system (flexible) | 2393 123 |
| 12 | Pressure gauge (HEA) | 2383 995 |
| 13 | Filter bag, mesh width 0,3 mm | 0097 531 |

HEA NOZZLES FOR LOW-MIST SPRAYING AT LOW PRESSURE



HEA stands for High Efficiency Airless, an innovative nozzle technology revolutionising airless spraying. HEA nozzles allow the pressure of the spray device to be reduced right down and allow it to work in the low-pressure range (ideally at 80 - 140 bar). The nozzles can be used with all TradeTip 3 nozzle holders and WAGNER devices.

Some paints may need to be diluted to achieve the best result possible. The experts at Wagner application technology have therefore tested a wide range of materials for you. Their recommendations can be found in the Wagner Spray Guide at sprayguide.wagner-group.com.

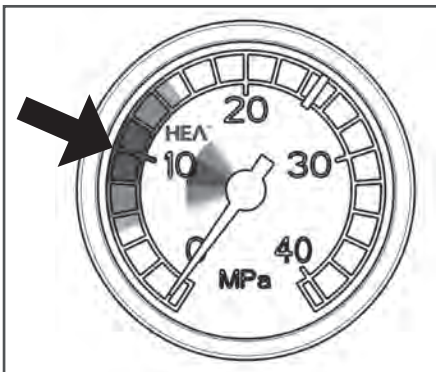

Set the low pressure in the HEA range and start.



Even spray pattern without spray edges.

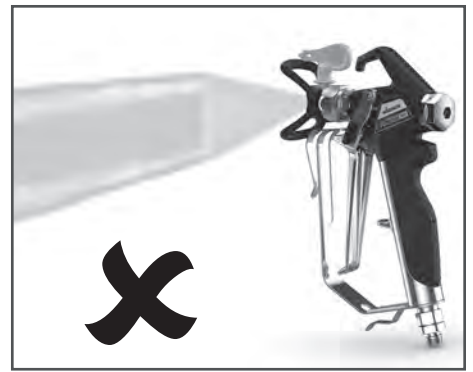

If edges are visible, slowly increase the pressure.

HEA tip table



All of the tips in the table below are supplied together with the appropriate gun filter.

| Application | Tip marking | Spray angle | Bore inch / mm | Spraying width mm 1) | Gun filter | Order no. |
|---|-------------|-------------|----------------|----------------------|------------|-----------|
| Synthetic-resin paints PVC paints | 211 | 20° | 0.011 / 0.28 | 120 | red | 0554211 |
| | 311 | 30° | 0.011 / 0.28 | 150 | red | 0554311 |
| | 411 | 40° | 0.011 / 0.28 | 190 | Rot | 0554411 |
| Paints, primers Fillers | 213 | 20° | 0.013 / 0.33 | 120 | red | 0554213 |
| | 313 | 30° | 0.013 / 0.33 | 150 | red | 0554313 |
| | 413 | 40° | 0.013 / 0.33 | 190 | red | 0554413 |
| Fillers Rust protection paints | 415 | 40° | 0.015 / 0.38 | 190 | yellow | 0554415 |
| | 515 | 50° | 0.015 / 0.38 | 225 | yellow | 0554515 |
| | 615 | 60° | 0.015 / 0.38 | 270 | yellow | 0554615 |
| Rust protection paints Latex paints Dispersions | 417 | 40° | 0.017 / 0.43 | 190 | white | 0554417 |
| | 517 | 50° | 0.017 / 0.43 | 225 | white | 0554517 |
| | 617 | 60° | 0.017 / 0.43 | 270 | white | 0554617 |
| Rust protection paints Latex paints Dispersions | 519 | 50° | 0.019 / 0.48 | 225 | white | 0554519 |
| | 619 | 60° | 0.019 / 0.48 | 270 | white | 0554619 |
| Flame retardant | 421 | 40° | 0.021 / 0.53 | 190 | white | 0554421 |
| | 521 | 50° | 0.021 / 0.53 | 225 | white | 0554521 |
| | 621 | 60° | 0.021 / 0.53 | 270 | white | 0554621 |

1) Spray width at about 30 cm to the object and 100 bar (10 MPa) pressure with synthetic-resin paint 20 DIN seconds.



Airless tip table

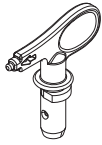

Wagner TradeTip 3 tip
up to 270 bar
(27 MPa)



without tip
G thread (7/8 - 14 UN)
Order no. 0289390

without tip
F thread (11/16 - 16 UN)
Order no. 0289391



All of the tips in the table below are supplied together with the appropriate gun filter.

| Application | Tip marking | Spray angle | Bore inch / mm | Spraying width mm 1) | Gun filter | Order no. |
|--|--|-------------|----------------|----------------------|------------|-----------|
| Water-thinnable and solvent-based paints and varnishes, oils, separating agents | 107 | 10° | 0.007 / 0.18 | 100 | red | 0553107 |
| | 207 | 20° | 0.007 / 0.18 | 120 | red | 0553207 |
| | 307 | 30° | 0.007 / 0.18 | 150 | red | 0553307 |
| | 407 | 40° | 0.007 / 0.18 | 190 | red | 0553407 |
| | 109 | 10° | 0.009 / 0.23 | 100 | red | 0553109 |
| | 209 | 20° | 0.009 / 0.23 | 120 | red | 0553209 |
| | 309 | 30° | 0.009 / 0.23 | 150 | red | 0553309 |
| | 409 | 40° | 0.009 / 0.23 | 190 | red | 0553409 |
| | 509 | 50° | 0.009 / 0.23 | 225 | red | 0553509 |
| | 609 | 60° | 0.009 / 0.23 | 270 | red | 0553609 |
| Synthetic-resin paints PVC paints | 111 | 10° | 0.011 / 0.28 | 100 | red | 0553111 |
| | 211 | 20° | 0.011 / 0.28 | 120 | red | 0553211 |
| | 311 | 30° | 0.011 / 0.28 | 150 | red | 0553311 |
| | 411 | 40° | 0.011 / 0.28 | 190 | red | 0553411 |
| | 511 | 50° | 0.011 / 0.28 | 225 | red | 0553511 |
| | 611 | 60° | 0.011 / 0.28 | 270 | red | 0553611 |
| Paints, primers Fillers | 113 | 10° | 0.013 / 0.33 | 100 | red | 0553113 |
| | 213 | 20° | 0.013 / 0.33 | 120 | red | 0553213 |
| | 313 | 30° | 0.013 / 0.33 | 150 | red | 0553313 |
| | 413 | 40° | 0.013 / 0.33 | 190 | red | 0553413 |
| | 513 | 50° | 0.013 / 0.33 | 225 | red | 0553513 |
| | 613 | 60° | 0.013 / 0.33 | 270 | red | 0553613 |
| | 813 | 80° | 0.013 / 0.33 | 330 | red | 0553813 |
| | Fillers Rust protection paints | 115 | 10° | 0.015 / 0.38 | 100 | yellow |
| 215 | | 20° | 0.015 / 0.38 | 120 | yellow | 0553215 |
| 315 | | 30° | 0.015 / 0.38 | 150 | yellow | 0553315 |
| 415 | | 40° | 0.015 / 0.38 | 190 | yellow | 0553415 |
| 515 | | 50° | 0.015 / 0.38 | 225 | yellow | 0553515 |
| 615 | | 60° | 0.015 / 0.38 | 270 | yellow | 0553615 |
| 715 | | 70° | 0.015 / 0.38 | 300 | yellow | 0553715 |
| 815 | | 80° | 0.015 / 0.38 | 330 | yellow | 0553815 |
| Rust protection paints Latex paints Dispersions | | 117 | 10° | 0.017 / 0.43 | 100 | white |
| | 217 | 20° | 0.017 / 0.43 | 120 | white | 0553217 |
| | 317 | 30° | 0.017 / 0.43 | 150 | white | 0553317 |
| | 417 | 40° | 0.017 / 0.43 | 190 | white | 0553417 |
| | 517 | 50° | 0.017 / 0.43 | 225 | white | 0553517 |
| | 617 | 60° | 0.017 / 0.43 | 270 | white | 0553617 |
| | 717 | 70° | 0.017 / 0.43 | 300 | white | 0553717 |
| | 817 | 80° | 0.017 / 0.43 | 330 | white | 0553817 |
| | Rust protection paints Latex paints Dispersions | 219 | 20° | 0.019 / 0.48 | 120 | white |
| 319 | | 30° | 0.019 / 0.48 | 150 | white | 0553319 |
| 419 | | 40° | 0.019 / 0.48 | 190 | white | 0553419 |
| 519 | | 50° | 0.019 / 0.48 | 225 | white | 0553519 |
| 619 | | 60° | 0.019 / 0.48 | 270 | white | 0553619 |
| 719 | | 70° | 0.019 / 0.48 | 300 | white | 0553719 |
| 819 | | 80° | 0.019 / 0.48 | 330 | white | 0553819 |
| 919 | | 90° | 0.019 / 0.48 | 385 | white | 0553919 |
| Flame retardant | | 221 | 20° | 0.021 / 0.53 | 120 | white |
| | 321 | 30° | 0.021 / 0.53 | 150 | white | 0553321 |
| | 421 | 40° | 0.021 / 0.53 | 190 | white | 0553421 |
| | 521 | 50° | 0.021 / 0.53 | 225 | white | 0553521 |
| | 621 | 60° | 0.021 / 0.53 | 270 | white | 0553621 |
| | 721 | 70° | 0.021 / 0.53 | 300 | white | 0553721 |
| | 821 | 80° | 0.021 / 0.53 | 330 | white | 0553821 |

1) Spray width at about 30 cm to the object and 100 bar (10 MPa) pressure with synthetic-resin paint 20 DIN seconds.



All of the tips in the table below are supplied together with the appropriate gun filter.

| Application | Tip marking | Spray angle | Bore inch / mm | Spraying width mm 1) | Gun filter | Order no. |
|--|-------------|--------------|----------------|----------------------|------------|-----------|
| Roof coatings | 223 | 20° | 0.023 / 0.58 | 120 | white | 0553223 |
| | 323 | 30° | 0.023 / 0.58 | 150 | white | 0553323 |
| | 423 | 40° | 0.023 / 0.58 | 190 | white | 0553423 |
| | 523 | 50° | 0.023 / 0.58 | 225 | white | 0553523 |
| | 623 | 60° | 0.023 / 0.58 | 270 | white | 0553623 |
| | 723 | 70° | 0.023 / 0.58 | 300 | white | 0553723 |
| | 823 | 80° | 0.023 / 0.58 | 330 | white | 0553823 |
| Thick-film materials, Corrosion protection Spray filler | 225 | 20° | 0.025 / 0.64 | 120 | white | 0553225 |
| | 325 | 30° | 0.025 / 0.64 | 150 | white | 0553325 |
| | 425 | 40° | 0.025 / 0.64 | 190 | white | 0553425 |
| | 525 | 50° | 0.025 / 0.64 | 225 | white | 0553525 |
| | 625 | 60° | 0.025 / 0.64 | 270 | white | 0553625 |
| | 725 | 70° | 0.025 / 0.64 | 300 | white | 0553725 |
| | 825 | 80° | 0.025 / 0.64 | 330 | white | 0553825 |
| | 227 | 20° | 0.027 / 0.69 | 120 | white | 0553227 |
| | 327 | 30° | 0.027 / 0.69 | 150 | white | 0553327 |
| | 427 | 40° | 0.027 / 0.69 | 190 | white | 0553427 |
| | 527 | 50° | 0.027 / 0.69 | 225 | white | 0553527 |
| | 627 | 60° | 0.027 / 0.69 | 270 | white | 0553627 |
| | 827 | 80° | 0.027 / 0.69 | 330 | white | 0553827 |
| | 229 | 20° | 0.029 / 0.75 | 120 | white | 0553229 |
| | 329 | 30° | 0.029 / 0.75 | 150 | white | 0553329 |
| | 429 | 40° | 0.029 / 0.75 | 190 | white | 0553429 |
| | 529 | 50° | 0.029 / 0.75 | 225 | white | 0553529 |
| | 629 | 60° | 0.029 / 0.75 | 270 | white | 0553629 |
| | 231 | 20° | 0.031 / 0.79 | 120 | white | 0553231 |
| | 331 | 30° | 0.031 / 0.79 | 150 | white | 0553331 |
| | 431 | 40° | 0.031 / 0.79 | 190 | white | 0553431 |
| | 531 | 50° | 0.031 / 0.79 | 225 | white | 0553531 |
| | 631 | 60° | 0.031 / 0.79 | 270 | white | 0553631 |
| | 731 | 70° | 0.031 / 0.79 | 300 | white | 0553731 |
| | 831 | 80° | 0.031 / 0.79 | 330 | white | 0553831 |
| | 233 | 20° | 0.033 / 0.83 | 120 | white | 0553233 |
| | 333 | 30° | 0.033 / 0.83 | 150 | white | 0553333 |
| | 433 | 40° | 0.033 / 0.83 | 190 | white | 0553433 |
| | 533 | 50° | 0.033 / 0.83 | 225 | white | 0553533 |
| | 633 | 60° | 0.033 / 0.83 | 270 | white | 0553633 |
| | 235 | 20° | 0.035 / 0.90 | 120 | white | 0553235 |
| | 335 | 30° | 0.035 / 0.90 | 150 | white | 0553335 |
| | 435 | 40° | 0.035 / 0.90 | 190 | white | 0553435 |
| 535 | 50° | 0.035 / 0.90 | 225 | white | 0553535 | |
| 635 | 60° | 0.035 / 0.90 | 270 | white | 0553635 | |
| 735 | 70° | 0.035 / 0.90 | 300 | white | 0553735 | |
| 439 | 40° | 0.039 / 0.99 | 190 | white | 0553439 | |
| 539 | 50° | 0.039 / 0.99 | 225 | white | 0553539 | |
| 639 | 60° | 0.039 / 0.99 | 270 | white | 0553639 | |
| Heavy duty applications | 243 | 20° | 0.043 / 1.10 | 120 | green | 0553243 |
| | 443 | 40° | 0.043 / 1.10 | 190 | green | 0553443 |
| | 543 | 50° | 0.043 / 1.10 | 225 | green | 0553543 |
| | 643 | 60° | 0.043 / 1.10 | 270 | green | 0553643 |
| | 445 | 40° | 0.045 / 1.14 | 190 | green | 0553445 |
| | 545 | 50° | 0.045 / 1.14 | 225 | green | 0553545 |
| | 645 | 60° | 0.045 / 1.14 | 270 | green | 0553645 |
| | 451 | 40° | 0.051 / 1.30 | 190 | green | 0553451 |
| | 551 | 50° | 0.051 / 1.30 | 225 | green | 0553551 |
| | 651 | 60° | 0.051 / 1.30 | 270 | green | 0553651 |
| | 252 | 20° | 0.052 / 1.32 | 120 | green | 0553252 |
| | 455 | 40° | 0.055 / 1.40 | 190 | green | 0553455 |
| | 555 | 50° | 0.055 / 1.40 | 225 | green | 0553555 |
| | 655 | 60° | 0.055 / 1.40 | 270 | green | 0553655 |
| | 261 | 20° | 0.061 / 1.55 | 120 | green | 0553261 |
| | 461 | 40° | 0.061 / 1.55 | 190 | green | 0553461 |
| | 561 | 50° | 0.061 / 1.55 | 225 | green | 0553561 |
| | 661 | 60° | 0.061 / 1.55 | 270 | green | 0553661 |
| | 263 | 20° | 0.063 / 1.60 | 120 | green | 0553263 |
| | 463 | 40° | 0.063 / 1.60 | 190 | green | 0553463 |
| | 565 | 50° | 0.065 / 1.65 | 225 | green | 0553565 |
| | 665 | 60° | 0.065 / 1.65 | 270 | green | 0553665 |
| | 267 | 20° | 0.067 / 1.70 | 120 | green | 0553267 |
| 467 | 40° | 0.067 / 1.70 | 190 | green | 0553467 | |

1) Spray width at about 30 cm to the object and 100 bar (10 MPa) pressure with synthetic-resin paint 20 DIN seconds.



2SpeedTip

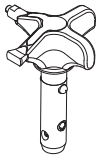

The innovative changeover nozzle from WAGNER combines two nozzle cores into one nozzle.



2 Speed Tip holder
Order no. 0271065

Tip table

| Object size | Painting material | | |
|------------------------|--|--|--|
| | Lacquer (L) | Emulsion (D) | Filler (S) |
| Small | | D5 Nozzles: 111 / 415 Order no. 0271 062 | S5 Nozzles: 225 / 629 Order no. 0271 064 |
| | | D7 Nozzles: 113 / 417 Order no. 0271 063 | |
| | L10 Nozzles: 208 / 510 Order no. 0271 042 | D10 Nozzles: 111 / 419 Order no. 0271 045 | S10 Nozzles: 527 / 235 Order no. 0271 049 |
| Medium | L20 Nozzles: 210 / 512 Order no. 0271 043 | D20 Nozzles: 115 / 421 Order no. 0271 046 | S20 Nozzles: 539 / 243 Order no. 0271 050 |
| Large | L30 Nozzles: 212 / 514 Order no. 0271 044 | D30 Nozzles: 115 / 423 Order no. 0271 047 | S30 Nozzles: 543 / 252 Order no. 0271 051 |
| X-Large | | D40 Nozzles: 117 / 427 Order no. 0271 048 | |
| Recommended gun filter | red | white | - |

11.2 SPARE PARTS SF 23 PRO

| ITEM | ORDER NO. | DESIGNATION |
|------|--------------------|---|
| 1 | 9953696 | Motor protection switch |
| 2 | 2393002 | Oval-head tapping screw 4,2 x 45 (2 pcs.) |
| 3 | 2393003 | Oval-head tapping screw 4,2 x 25 (2 pcs.) |
| 4 | 2388381 | Oval-head tapping screw 4,2 x 22 |
| 5 | 2388377 | Disc |
| 6 | 2369533 | Cover |
| 7 | 2304608 | Round cord |
| 8 | 2393015 | Capacitor 25uf 400V assy. |
| 9 | 2393018 | Oval-head screw M4x18 (4 pcs.) |
| 10 | 2393035 | Terminal box assy. (pos. 7-9) |
| 11 | 2369517 | Motor seal |
| 12 | 2369436 | Reducing double nipple |
| 13 | 0340257 | Pressure gauge assy. AUS |
| 14 | 2369454 | Inlet |
| 15 | 2388291 | Inlet valve housing |
| 16 | 2369455 | Clamp |
| 17 | 2393043 | Inlet valve assy. (incl. pos. 18) |
| 18 | 2369458 | Sealing ring |
| 19 | 2393044 | Oil level measuring set |
| 20 | 2369586 | Fitting |
| 21 | 2393047 | Pressure relief knob assy. |
| 22 | 2369631 | Pressure relief valve (incl. pos. 23) |
| 23 | 9971395 | O-ring |
| 24 | 2398248 | Label SF 23 Pro |
| 25 | 0252475 | Pressure gauge assy. EU |
| 26 | 2393102 | Outlet valve housing assy. |
| 27 | 2393105 | O-ring and sealing ring |
| 28 | 2393106 | Outlet valve assy. (incl. pos. 27) |
| 29 | 2388374 | Cable gland |
| 30 | 2394776 0341520 | Mains cable EU Mains cable AUS |
| 31 | 2400157 2400156 | Mains cable assy. EU (pos 29-30) Mains cable assy. AUS (pos 29-30) |

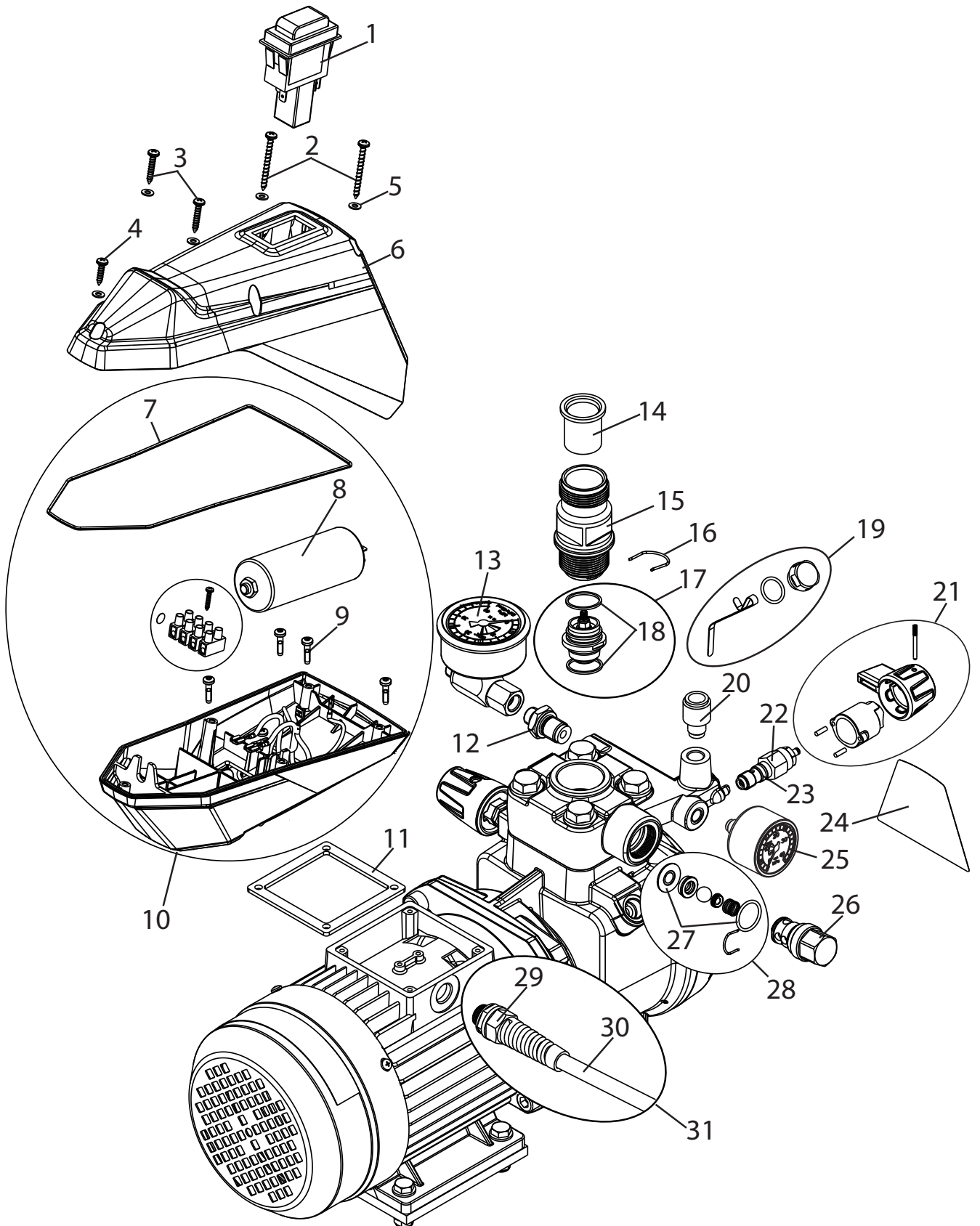

Spare parts diagram SF 23 Pro

11.3 SPARE PARTS LIST HIGH-PRESSURE FILTER

| ITEM | ORDER NO. | DESIGNATION |
|------|-----------|---------------------------------------|
| 1 | 0097 121 | High-pressure filter HF- 01 compl. |
| 2 | 0097 301 | Filter block |
| 3 | 0097 302 | Filter housing |
| 4 | 0097 303 | Hollow screw |
| 5 | 0097 304 | Seal ring |
| 6 | 9970 110 | Seal ring |
| 7 | 9974 027 | O-ring 30x2 (PTFE) |
| 8 | 9971 401 | O-ring 16x2 (PTFE) |
| 9 | 0508 749 | Bearing spring |
| 10 | 0508 603 | Bearing ring |
| 11 | 0508 748 | Filter insert 60 meshes |
| | 0508 450 | Optional: Filter insert 100 meshes |
| | 0508 449 | Filter insert 30 meshes |
| 12 | 9994 245 | Pressure spring |

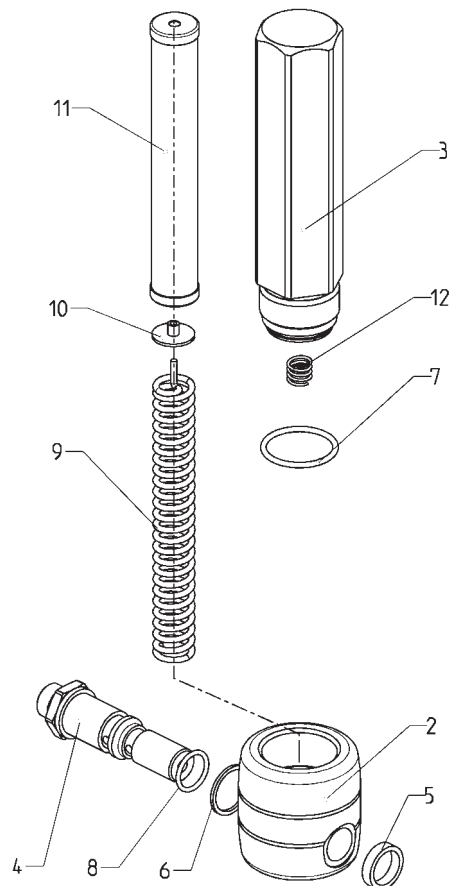

Spare parts diagram high-pressure filter

11.4 SPARE PARTS LIST HOPPER

| ITEM | ORDER-NO | DESIGNATION |
|------|----------|---|
| 1 | 0341 265 | Hopper 5l, assy. (pos. 2-6) |
| 2 | 0340 901 | Cover |
| 3 | 9902 306 | Sheet metal screw 3,9x13 (2) |
| 4 | 0037 607 | Filter disk, mesh width 0,8 mm |
| | 0003 756 | Optional: Filter disk, mesh width 0,4 mm |
| 5 | 0340 904 | Hopper |
| 6 | 0340 908 | Return pipe |

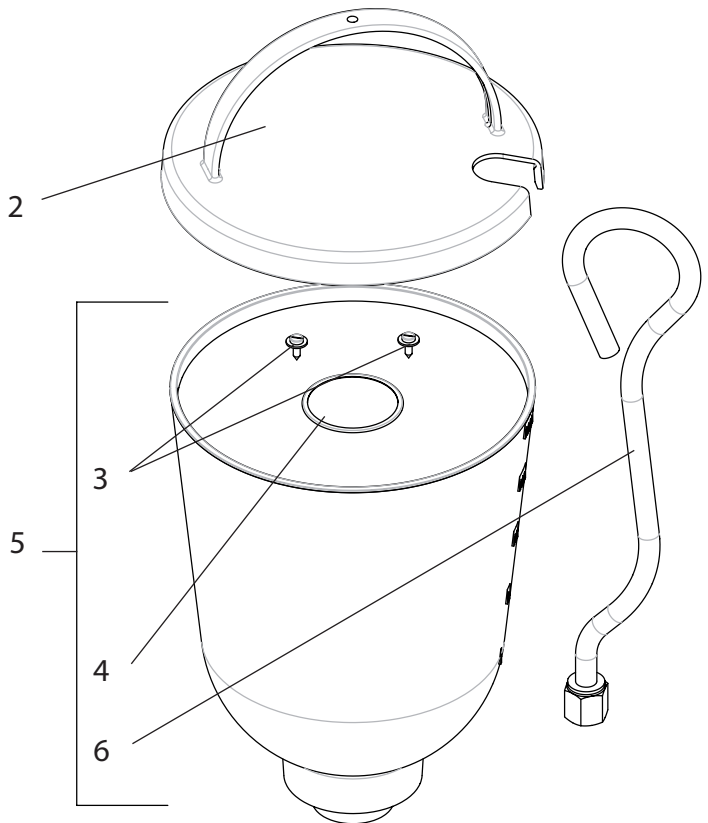

Spare parts diagram hopper

11.5 SPARE PARTS LIST TROLLEY

| ITEM | ORDER NO. | DESIGNATION |
|------|-----------|-----------------------------------|
| 1 | 2369570 | Handle |
| 2 | 13806 | Sleeve |
| 3 | 2396299 | Half-hollow rivet |
| 4 | 2369585 | Cleaning cup |
| 5 | 2393786 | Cleaning cup holder |
| 6 | 2369550 | Bottom frame, cart |
| 7 | 2369578 | Foot, damping |
| 8 | 9920304 | Washer |
| 9 | 2391181 | Hexagon socket head cap screw |
| 10 | 2393118 | Foot, damping assy. (pos. 7-9) |
| 11 | 9900118 | Hexagon screw |
| 12 | 2369545 | Plate, damping |
| 13 | 9920102 | Washer |
| 14 | 9910208 | Hexagon nut |
| 15 | 2393119 | Plate, damping assy. (pos. 11-14) |
| 16 | 2369556 | Wheel |
| 17 | 9994950 | Wheel cap |
| 18 | 2393121 | Wheel assy. (pos. 16, 17) |
| 19 | 2388543 | Foot |

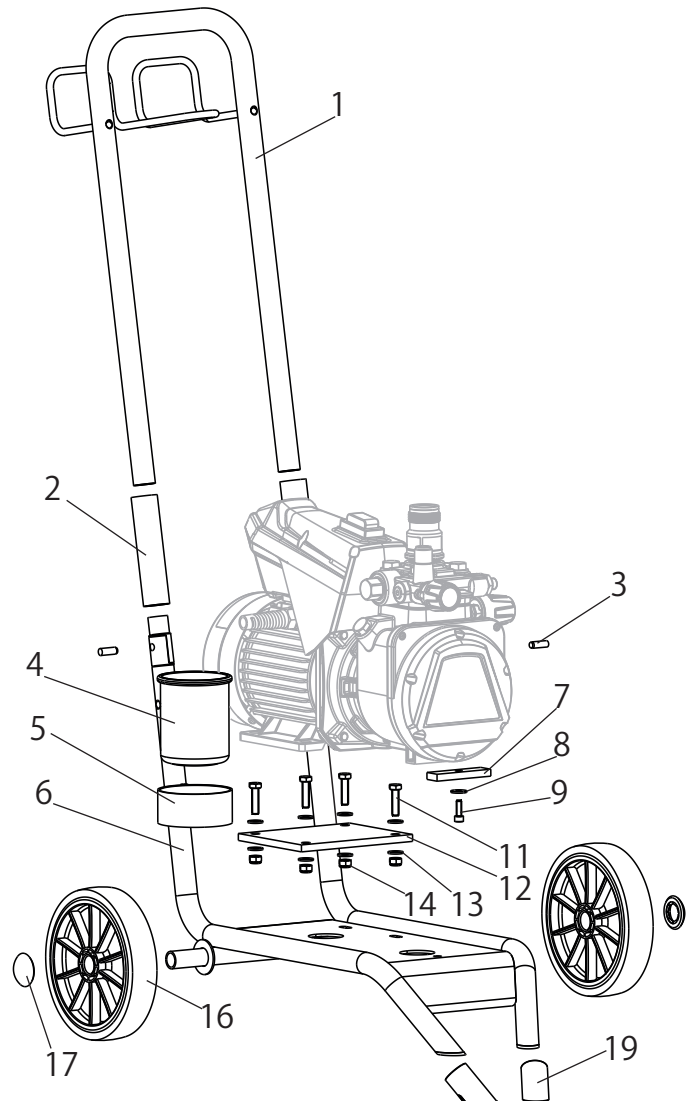

Spare parts diagram trolley

11.6 SPARE PARTS LIST SUCTION SYSTEM

| ITEM | ORDER NO. | DESIGNATION |
|------|-----------|-----------------------------------|
| | 2393123 | Suction system assy. |
| 1 | 2390605 | Suction hose assy. (incl. filter) |
| 2 | 2390606 | Return hose assy. |
| 3 | 2323325 | Suction filter |

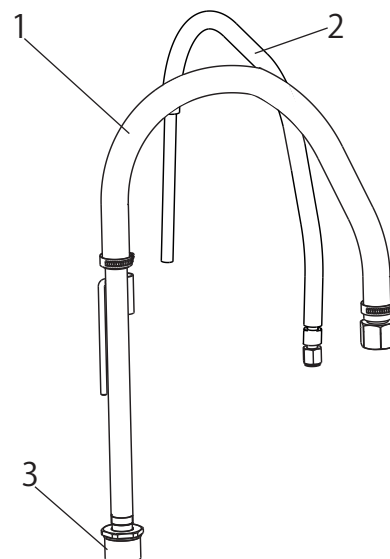

Spare parts diagram suction system

TESTING OF THE UNIT

For safety reasons, we would recommend having the device checked by an expert as required but at least every 12 months to ensure that it can continue to operate safely.

In the case of unused devices, the check can be postponed until they are next started up.

All (potentially deviating) national inspection and maintenance regulations must also be observed.

If you have any questions, please contact the customer service team at Wagner.

IMPORTANT INFORMATION ON PRODUCT LIABILITY

According to an EU directive, the manufacturer is only liable without limitation for faults in the product if all parts come from the manufacturer or have been approved by the manufacturer and have been mounted to the device and are operated properly. If third-party accessories or spare parts are used, the manufacturer is exonerated wholly or partly from his/her liability if use of the third-party accessories or spare parts have caused a defect in the product. In extreme cases, the relevant authorities can completely prohibit using the entire device.

With original WAGNER accessories and spare parts, compliance with all safety regulations is guaranteed.

NOTE ON DISPOSAL

In observance of the European Directive 2002/96/EC on waste electrical and electronic equipment and implementation in accordance with national law, this product is not to be disposed of together with household waste material but must be recycled in an environmentally friendly way!



Wagner or one of our dealers will take back your used Wagner waste electrical or electronic equipment and will dispose of it for you in an environmentally friendly way. Please ask your local Wagner service centre or dealer for details or contact us direct.

GUARANTEE DECLARATION

(Status 01.02.2009)

1. Scope of guarantee

All Wagner professional colour application devices (hereafter referred to as products) are carefully inspected, tested and are subject to strict checks under Wagner quality assurance. Wagner exclusively issues extended guarantees to commercial or professional users (hereafter referred to as "customer") who have purchased the product in an authorised specialist shop, and which relate to the products listed for that customer on the Internet under www.wagner-group.com/profi-guarantee.

The buyer's claim for liability for defects from the purchase agreement with the seller as well as statutory rights are not impaired by this guarantee.

We provide a guarantee in that we decide whether to replace or repair the product or individual parts, or take the device back and reimburse the purchase price. The costs for materials and working hours are our responsibility. Replaced products or parts become our property.

2. Guarantee period and registration

The guarantee period amounts to 36 months. For industrial use or equal wear, such as shift operations in particular, or in the event of rentals it amounts to 12 months.

Systems driven by petrol or air are also guaranteed for a 12 month period.

The guarantee period begins with the day of delivery by the authorised specialist shop. The date on the original purchase document is authoritative.

For all products bought in authorised specialist shops from 01.02.2009 the guarantee period is extended to 24 months providing the buyer of these devices registers in accordance with the following conditions within 4 weeks of the day of delivery by the authorised specialist shop.

Registration can be completed on the Internet under www.wagner-group.com/profi-guarantee.

The guarantee certificate is valid as confirmation, as is the original purchase document that carries the date of the purchase. Registration is only possible if the buyer is in agreement with having the data being stored that is entered during registration.

When services are carried out under guarantee the guarantee period for the product is neither extended nor renewed.

Once the guarantee period has expired, claims made against the guarantee or from the guarantee can no longer be enforced.

3. Handling

If defects can be seen in the materials, processing or performance of the device during the guarantee period, guarantee claims must be made immediately, or at the latest within a period of 2 weeks.

The authorised specialist shop that delivered the device is entitled to accept guarantee claims. Guarantee claims may also be made to the service centres named in our operating instructions. The product has to be sent without charge or presented together with the original purchase document that includes details of the purchase date and the name of the product. In order to claim for an extension to the guarantee, the guarantee certificate must be included.

The costs as well as the risk of loss or damage to the product in transit or by the centre that accepts the guarantee claims or who delivers the repaired product, are the responsibility of the customer.

4. Exclusion of guarantee

Guarantee claims cannot be considered

- for parts that are subject to wear and tear due to use or other natural wear and tear, as well as defects in the product that are a result of natural wear and tear, or wear and tear due to use. This includes in particular cables, valves, packaging, jets, cylinders, pistons, means-carrying housing components, filters, pipes, seals, rotors, stators, etc. Damage due to wear and tear that is caused in particular by sanded coating materials, such as dispersions, plaster, putty, adhesives, glazes, quartz foundation.
- in the event of errors in devices that are due to non-compliance with the operating instructions, unsuitable or unprofessional use, incorrect assembly and/or commissioning by the buyer or by a third party, or utilisation other than is intended, abnormal ambient conditions, unsuitable coating materials, unsuitable operating conditions, operation with the incorrect mains voltage supply/frequency, over-operation or defective servicing or care and/or cleaning.
- for errors in the device that have been caused by using accessory parts, additional components or spare parts that are not original Wagner parts.
- for products to which modifications or additions have been carried out.
- for products where the serial number has been removed or is illegible
- for products to which attempts at repairs have been carried out by unauthorised persons.
- for products with slight deviations from the target properties, which are negligible with regard to the value and usability of the device.
- for products that have been partially or fully taken apart.

5. Additional regulations.

The above guarantees apply exclusively to products that have been bought by authorised specialist shops in the EU, CIS, Australia and are used within the reference country.

If the check shows that the case is not a guarantee case, repairs are carried out at the expense of the buyer.

The above regulations manage the legal relationship to us conclusively. Additional claims, in particular for damages and losses of any type, which occur as a result of the product or its use, are excluded from the product liability act except with regard to the area of application.

Claims for liability for defects to the specialist trader remain unaffected.

German law applies to this guarantee. The contractual language is German. In the event that the meaning of the German and a foreign text of this guarantee deviate from one another, the meaning of the German text has priority.

J. Wagner GmbH
Division Professional Finishing
Otto Lilienthal Strasse 18
88677 Markdorf
Federal Republic of Germany

Subject to modifications

EU Declaration of conformity

We declare under sole responsibility that this product conforms to the following relevant stipulations:
2006/42/EC, 2014/30/EU, 2011/65/EU, 2012/19/EU

Applied harmonised norms:
EN 12621, EN ISO 12100, EN 1953, EN 60204-1, EN 61000-3-2, EN 61000-3-11, EN 61000-6-1, EN 61000-6-3

The EU declaration of conformity is enclosed with the product.

If required, it can be re-ordered using order number **2398553**.

- A** J. Wagner Ges.m.b.H.
Ottogasse 2/20
2333 Leopoldsdorf
Österreich
Tel. +43/ 2235 / 44 158
Telefax +43/ 2235 / 44 163
office@wagner-group.at
- B** WSB Finishing Equipment
Veilinglaan 56-58
1861 Meise-Wolvertem
Belgium
Tel. +32/2/269 46 75
Telefax +32/2/269 78 45
info@wagner-wsb.nl
- CH** Wagner International AG
Industriestrasse 22
9450 Altstätten
Schweiz
Tel. +41/71 / 7 57 22 11
Telefax +41/71 / 7 57 22 22
wagner@wagner-group.ch
- D** J. Wagner GmbH
Otto-Lilienthal-Straße 18
D-88677 Markdorf
Postfach 11 20
D-88669 Markdorf
Deutschland
Tel.: +49 / 75 44 / 505 -1664
Fax: +49 / 75 44 / 505 -1155
wagner@wagner-group.com
www.wagner-group.com
- CZ** E-Coreco s.r.o.
Na Roudné 102
301 00 Plzeň
Czechia
Tel. +420 734 792 823
Telefax 420 227 077 364
info@aplikacebarev.cz
- DK** Wagner Spraytech
Scandinavia A/S
Helgeshøj Allé 28
2630 Taastrup
Denmark
Tel. +45 43 27 18 18
Telefax +45 43 43 05 28
wagner@wagner-group.dk
- E** Makimport Herramientas, S.L.
C/ Méjico nº 6
Pol. El Descubrimiento
28806 Alcalá de Henares (Madrid)
Tel. 902 199 021/ 91 879 72 00
Telefax 91 883 19 59
ventas@grupo-k.es
info@grupo-k.es
- F** Euromair Antony
S.A.V. Ile-de-France
12-14, av. F. Sommer
92160 Antony
Tel. 01.55.59.92.42
Telefax +33 (0) 1 69 81 72 57
conseil.paris@euromair.com
- F** Euromair Distribution
Siège Social / S.A.V. Sud
343, bd. F. Perrin
13106 Rousset Cedex
Tel. 04.42.29.08.96
Telefax 04.42.53.44.36
conseil@euromair.com
- GB** Wagner Spraytech (UK) Limited
Innovation Centre
Silverstone Park
Silverstone
Northants NN12 8GX
Great Britain
Tel. 01327 368410
enquiries@wagnerspraytech.co.uk
- I** Wagner S.p.A.
23868 Valmadrera (Lc)
Via Santa Vecchia, 109
Italia
Tel./Fax 0341 210100 (centralino)

wagner_it_va@wagner-group.com
- NL** WSB Finishing Equipment BV
De Heldinnenlaan 200,
3543 MB Utrecht
Netherlands
Tel. +31/ 30/241 41 55
Telefax +31/ 30/241 17 87
info@wagner-wsb.nl
- S** Wagner Spraytech
Scandinavia A/S
Helgeshøj Allé 28
2630 Taastrup
Denmark
Tel. +45 43 27 18 18
Telefax +45 43 43 05 28
wagner@wagner-group.dk
- RU** ООО Мефферт Полилюкс
142407 Россия, Московская обл,
Ногинский р-н, территория
«Ногинск-Технопарк» д.14
Tel. +7 495 221 6666
Telefax +7 495 99 55 88 2
2216666@m-p-l.ru
dis@m-p-l.ru