

WAGNER

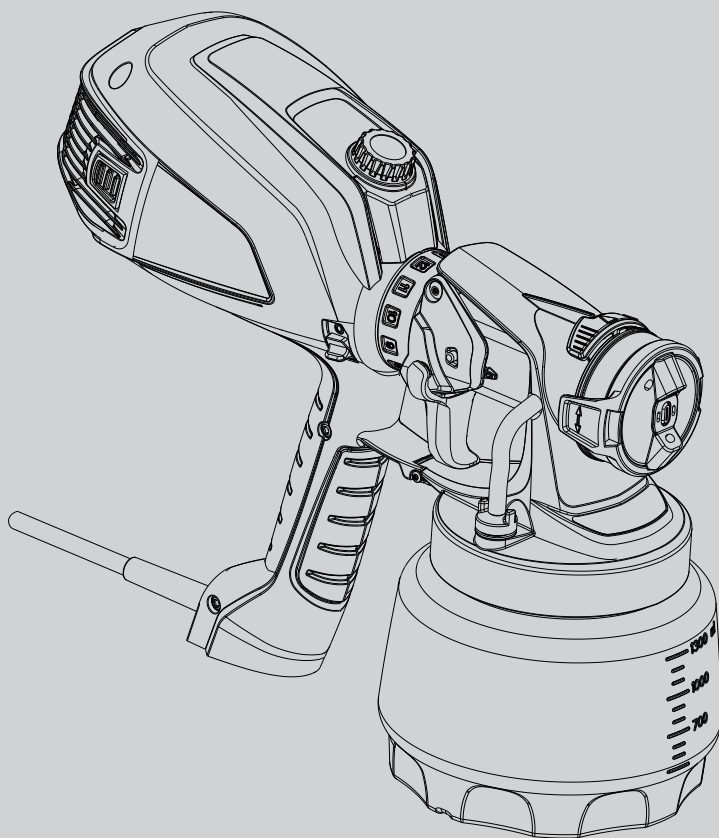

UNIVERSAL SPRAYER FLEXIO ELITE OPERATING INSTRUCTIONS

AUS

1

OVERVIEW

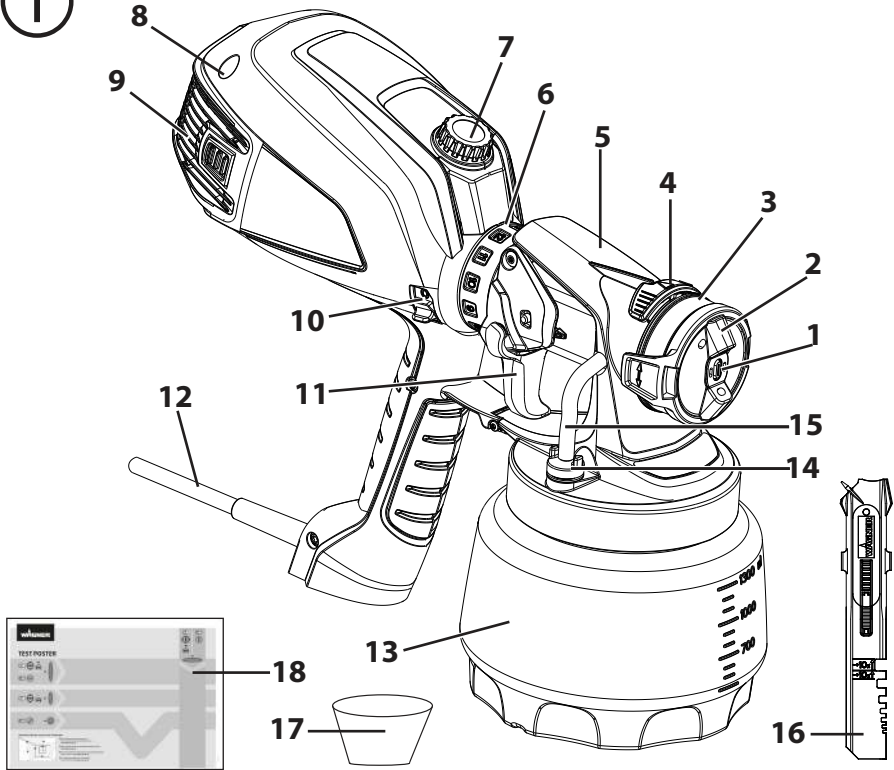

2

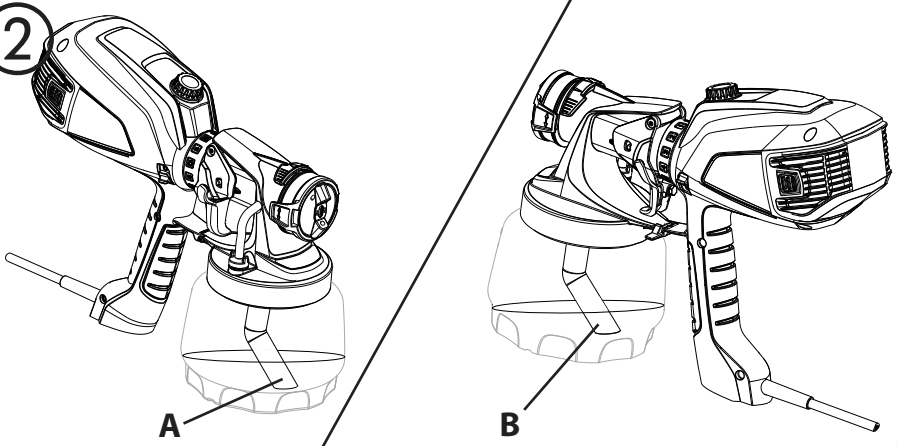

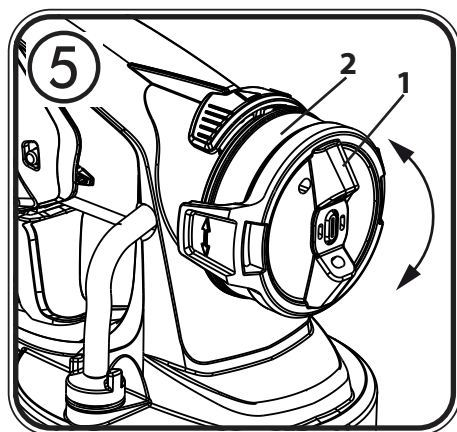
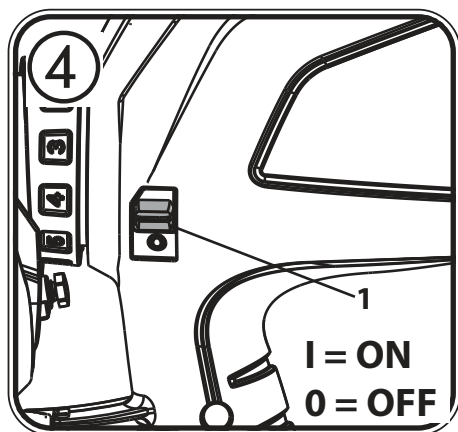
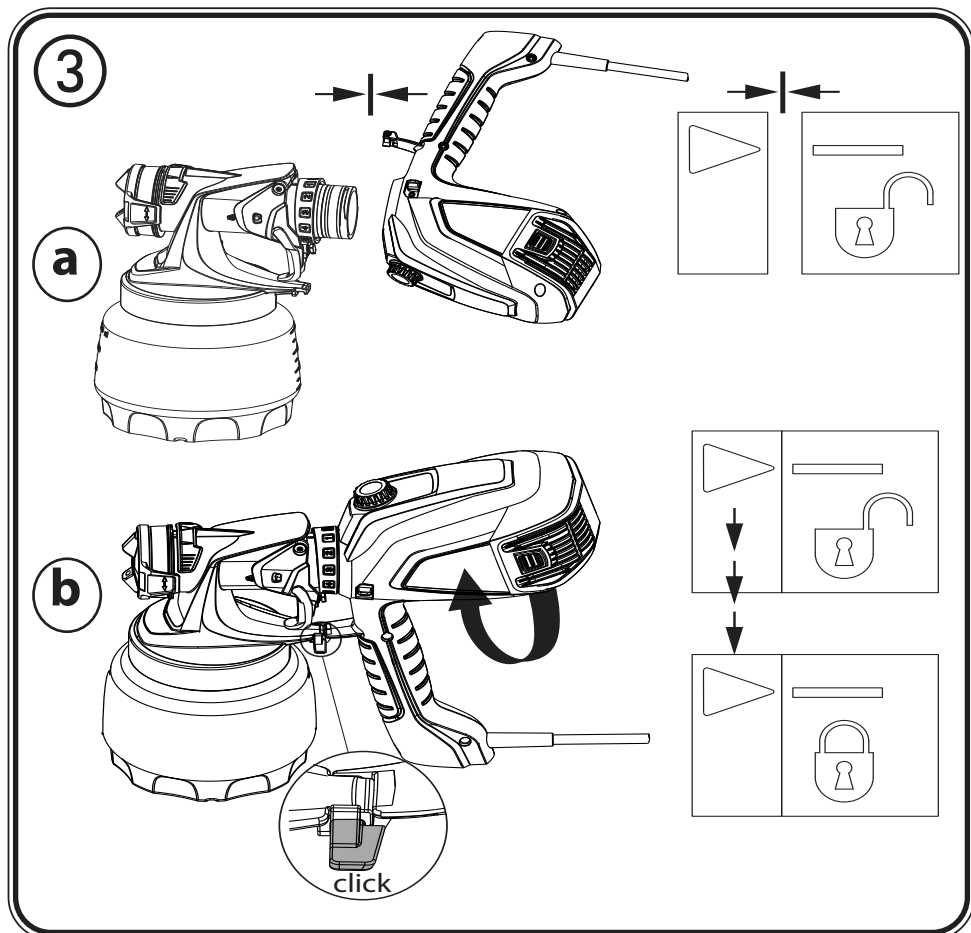

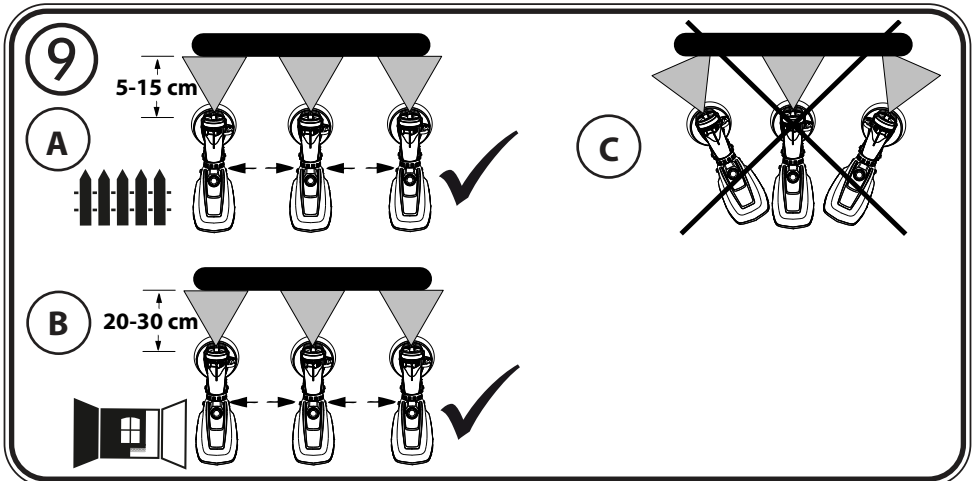
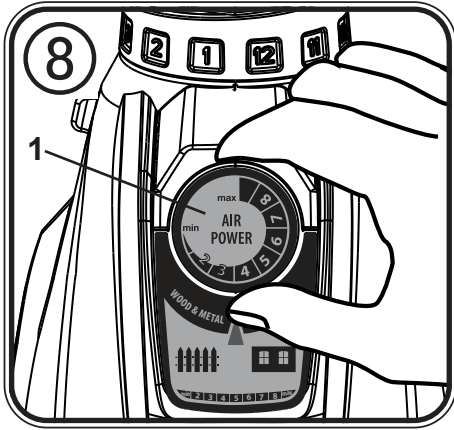
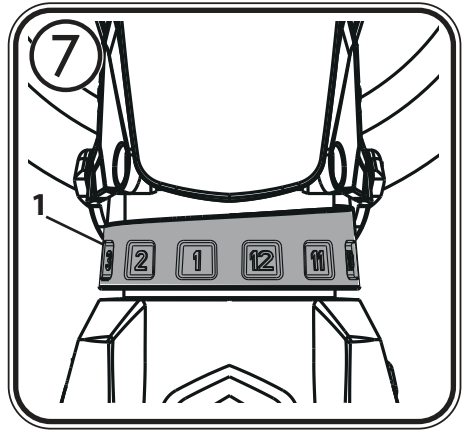
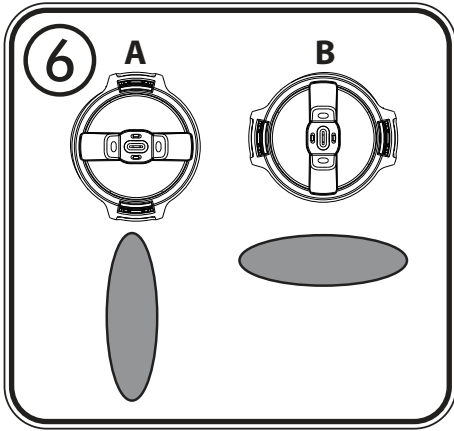

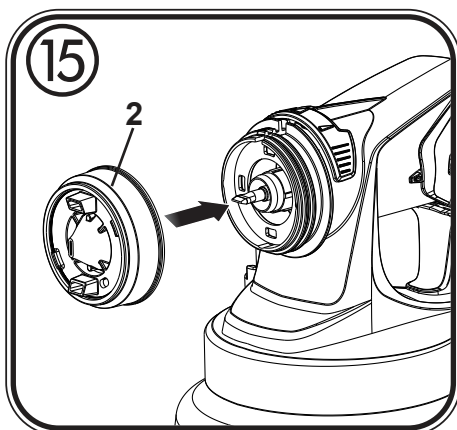
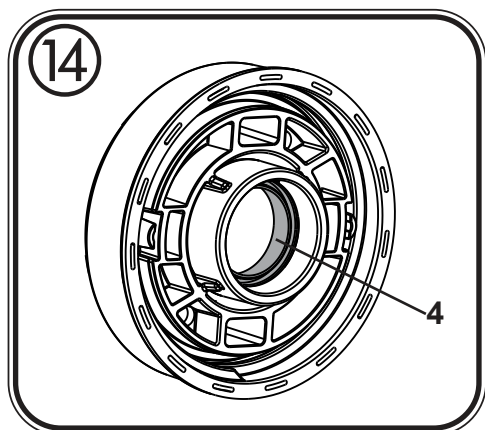
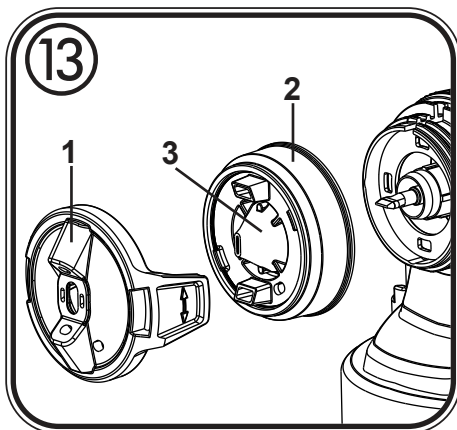
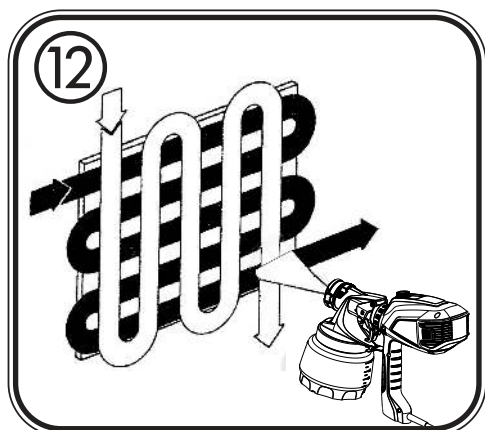
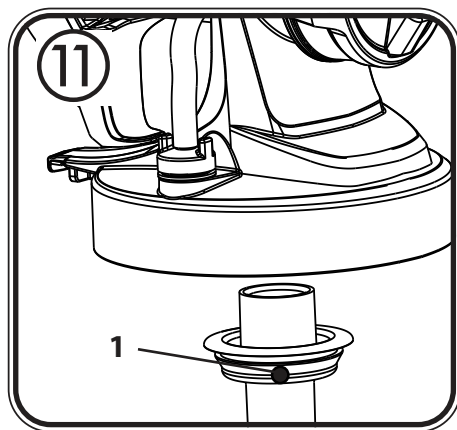
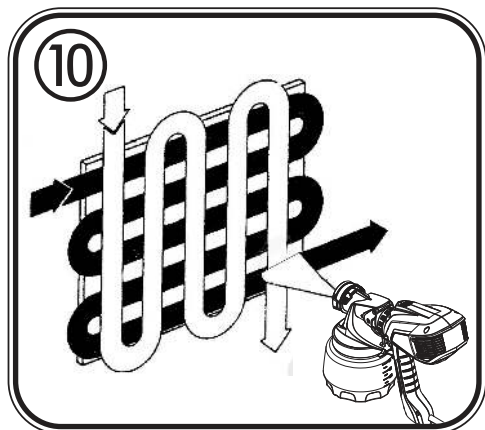

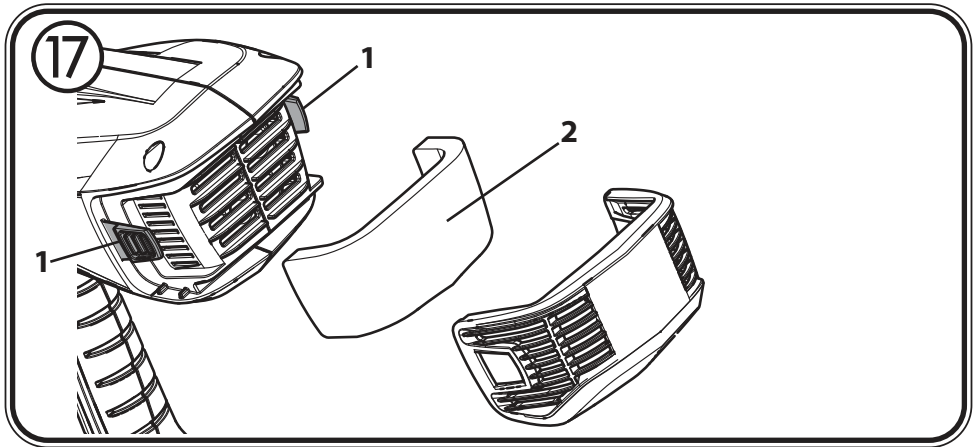
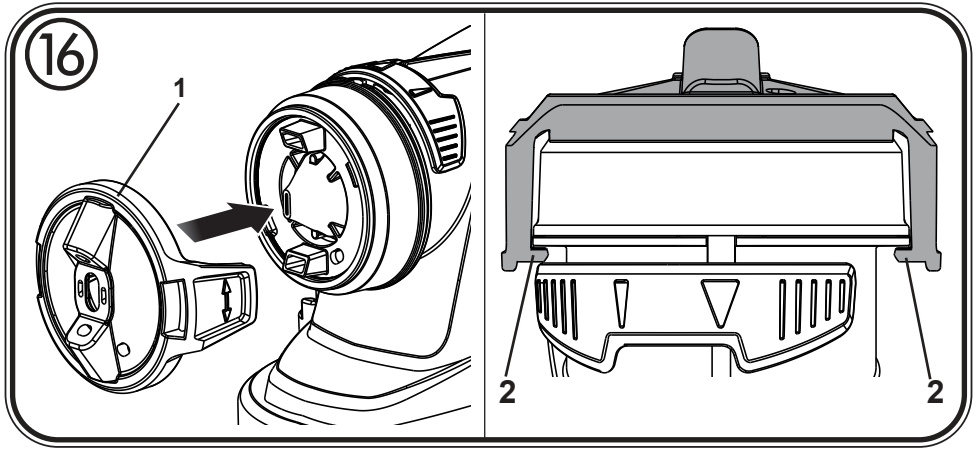

18

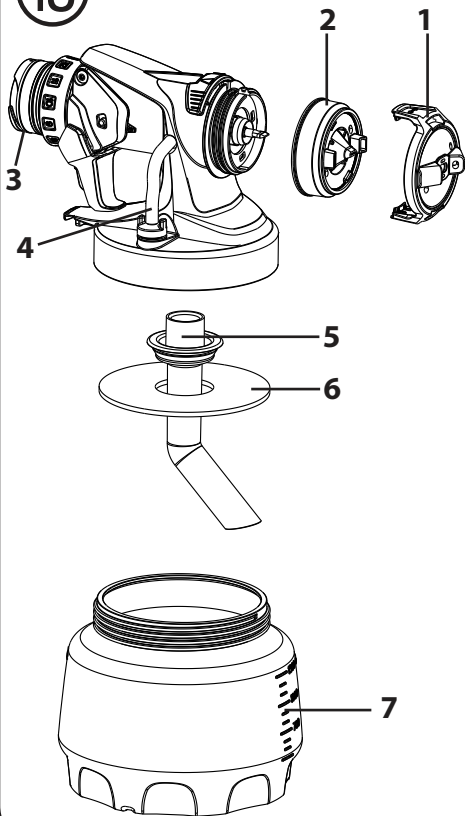

19

SPARE PARTS

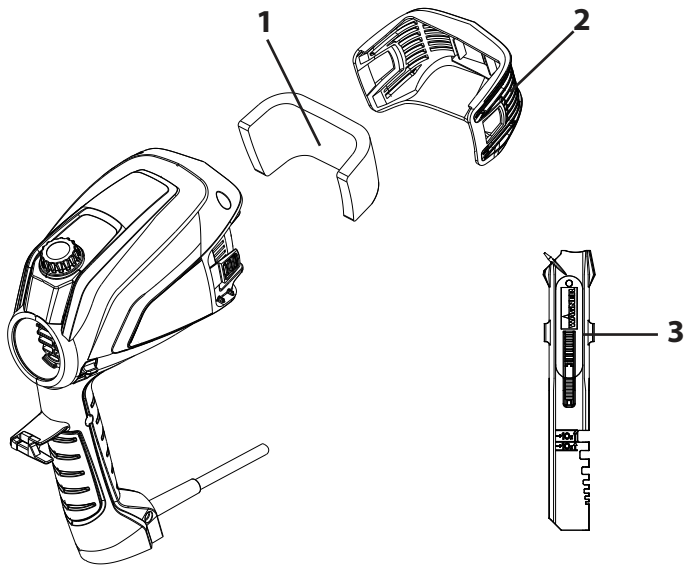

MANY THANKS FOR PLACING YOUR TRUST IN US

We would like to congratulate you on purchasing this brand product from Wagner; we are sure that you will enjoy working with it greatly.





Please read the Operating Manual carefully and observe the safety information before starting the device. Store the Operating Manual in a safe place close to the product in case it needs to be used by someone else.

We would be happy to be of assistance if you have any questions, suggestions or requests. Please contact us via the phone number included on the back page or via our homepage, www.wagner-group.com/service.

Contents

1. Explanation of symbols used	10
2. General Safety Instructions	10
3. Safety Instructions for Spray Guns	13
4. Description/ Scope of delivery	14
5. Field of application	14
6. Coating Materials Suitable for Use	14
7. Coating Materials Not Suitable for Use.....	15
8. Preparation of the workplace (for interior wall paint)	15
9. Preparation of the Coating Material	15
10. Start-up	16
11. Selecting the Spray Setting	16
12. Adjusting the Material Volume	17
13. Setting the Amount of Air (Fig. 8).....	17
14. Spray Technique.....	17
15. Interruption of Work.....	18
16. Taking Out of Operation and Cleaning.....	18
17. Cleaning the Wall Extra I-Spray spray attachment	19
18. Maintenance	20
19. Spare Parts	20
20. Accessories.....	21
21. Correction of Malfunctions.....	21
22. Technical Data.....	22
23. Environmental protection.....	23
24. Important Note regarding Product Liability!	23

1. Explanation of symbols used

	This symbol indicates a potential danger for you or for the device. Under this symbol you can find important information on how to avoid injuries and damage to the device.
	Danger of electrical shock
	Indicates tips for use and other particularly useful information.
	Devices and accessories marked with this symbol are suitable for processing low-viscosity materials such as paints, glazes and wall paints specifically designed for this purpose. If a material bears this logo, it is particularly well suited for use with the relevant device.
	Devices and accessories marked with this symbol are suitable for processing high-viscosity materials such as e.g. interior wall paints (dispersions and latex paints). If a material bears this logo, it is particularly well suited for use with the relevant device.

2. General Safety Instructions

WARNING! *Read all safety information, instructions, illustrations and technical data provided with this power tool. Failure to observe the following instructions may cause electric shock, fire and/or severe injuries. **Keep all safety information and instructions for future reference.** The term "power tool" used in this safety information refers to mains-operated power tools (with power cable) and to battery-powered power tools (without power cable).*



1. Safety at the workplace

- a) **Keep your workplace clean and well lit.** *Disorder or unlit workplaces may result in accidents.*
- b) **Do not work with the power tool in potentially explosive environments where there are flammable fluids, gases or dust.** *Power tools generate sparks that can ignite the dust or vapors.*
- c) **Keep children and other persons away when using the power tool.** *If distracted, you may lose control of the power tool.*

2. Electrical Safety

- a) **The connection plug of the power tool must fit in the socket. The plug may not be modified in any form. Verwenden Sie keine Adapterstecker gemeinsam mit schutzgeerdeten Elektrowerkzeugen.** *Unmodified plugs and suitable sockets reduce the risk of an electric shock.*
- b) **Avoid physical contact with earthed surfaces such as pipes, heating elements, stoves and refrigerators.** *The risk through electric shock increases if your body is earthed.*
- c) **Keep power tools away from rain or moisture.** *Water penetrating into a power tool increases the risk of an electric shock.*
- d) **Do not misuse the power cord to carry the power tool, hang up the power tool or pull the plug out of the socket. Keep the power cord away from heat, oil, sharp edges or moving parts.** *Damaged or entangled power cords increase the risk of an electric shock.*
- e) **If you are working with a power tool outdoors, only use extension cords that are suitable for the outdoor area.** *Using an extension cord that is suitable for the outdoor area reduces the risk of an electric shock.*
- f) **If the power tool must be used in a moist environment, use a ground fault circuit interrupter.** *Using a residual current operated circuit-breaker avoids the risk of electric shock.*

3. Safety of Persons

- a) **Be attentive. Pay attention to what you are doing and work sensibly with a power tool. Do not use the power tool if you are tired or under the influence of drugs, alcohol or medication.** *One moment of carelessness when using the power tool may cause serious injuries.*
- b) **Wear personal safety equipment and always wear safety goggles** *Wearing personal protective equipment, such as dust mask, non-slip safety shoes, safety helmet or ear protection, depending on the type of power tools, reduces the risk of injury.*
- c) **Avoid accidental starting-up. Make sure that the power tool is switched off before you connect it to the power tool and/or battery, pick it up or carry it.** *Accidents may happen if you have your finger on the switch while carrying the power tool or if the device is switched on when you connect it to the power supply.*
- d) **Remove setting tools or wrenches before switching on the power tool.** *A tool or key in a rotating part of the power tool can cause injuries.*

- e) **Avoid an unnatural posture. Ensure that you are standing securely and have your balance at all times.** *This allows you can better control the power tool in unexpected situations.*
- f) **Wear suitable clothing. Do not wear wide clothing or jewellery. Keep your hair, clothes and gloves away from moving parts.** *Loose clothing, jewellery or long hair can be caught in moving parts.*
- g) **Do not lull yourself into a false sense of security and do not think yourself above the safety rules for electric tools, even if you are familiar with the electric tool following extensive practical experience.** *Careless use can lead to serious injuries in fractions of a second.*

4. Usage and treatment of the electric tool

- a) **Do not overload the power tool. Use the power tool designed for the work that you are doing.** *You work better and safer in the specified performance range if you use the suitable power tool.*
- b) **Do not use power tools whose switch is defective.** *A power tool that cannot be switched on or off is dangerous and has to be repaired.*
- c) **Disconnect the plug from the socket and/or take out a removable battery before you make device adjustments, change accessories or put the power tool away.** *This precautionary measure prevents the power tool from starting unintentionally.*
- d) **Store unused power tools so that they are inaccessible to children. Do not let persons use the tool who are not familiar with it or who have not read these instructions.** *Power tools are dangerous when they are used by inexperienced persons.*
- e) **Maintain the power tool and insertion tools with care. Check whether moving device parts are working flawlessly and are not jamming, whether parts are broken or damaged so that as to impair the function of the power tool. Have damaged parts repaired before using the power tool.** *Many accidents have their origin in power tools that have been maintained badly.*
- f) **Use the power tool, accessories, insert tools, etc. in accordance with these instructions and in a fashion specified for this special tool type. Take the working conditions and the activity to be carried out into consideration.** *The use of power tools for purposes other than the intended ones can lead to dangerous situations.*
- g) **Keep the handles and grip surfaces dry, clean and free of oil and grease.** *Slippery handles and grip surfaces hamper safe operation and control of the electric tool in unforeseen situations.*

5. Service

- a) **Only have your power tool repaired by a qualified specialist and only use original spare parts.** *This ensures that the tool safety is maintained.*
- b) **If the supply cord is damaged, it must be replaced by the manufacturer or its service agent or a similarly qualified person in order to avoid a safety hazard.**

3. Safety Instructions for Spray Guns

- **Caution!** Wear breathing equipment: Paint mist and solvent vapors are damaging to health. Always wear breathing equipment and only work in well ventilated rooms or using supplementary ventilating equipment. It is advisable to wear working clothing, safety glasses, ear protection and gloves.



CAUTION: DANGER OF INJURY!

Never point the spray stream towards human beings or animals.



Sockets and plugs must be masked. Risk of an electric shock as a consequence of sprayed material entering the socket!



Attention! Never operate the device if the nozzle seal is either damaged or missing. If the nozzle seal is either missing or damaged liquids can enter the device and increase the risk of an electric shock. Check the nozzle seal before each use and tighten the union nut.

- Do not use the spray guns to spray flammable substances.
- The spray guns are not to be cleaned with flammable solvents.
- Caution against dangers that can arise from the sprayed substance and observe the text and information on the containers or the specifications given by the substance manufacturer.
- Do not spray any liquid of unknown hazard potential.
- The device may not be used in workplaces covered by the explosion-protection regulations.
- To avoid the hazard of explosion when spraying, provide for effective natural or artificial ventilation.
- There must be no sources of ignition such as, for example, open fires, smoke of lit cigarettes, cigars and tobacco pipes, sparks, glowing wires, hot surfaces, etc. in the vicinity during spraying.
- When working with the Flexio Elite indoors as well as outdoors ensure that no solvent vapors are sucked in by the spray gun.
- The spray gun is not a toy; children must therefore not be allowed to handle it or play with it.
- Before working on the spray gun remove the power plug from the socket.
- Cover areas that are **not** to be sprayed. When working keep in mind that wind, for example, may transport paint mist over great distances and cause damage.

- Never open the device yourself in order to carry out repairs in the electrical system!
- The units may only be used with a functional valve. **If paints rises in the ventilating hose (Fig. 1, item 15) do not operate the unit further!** Dismantle and clean the ventilating hose, valve and diaphragm and replace the diaphragm if necessary.
- **Do not lay the spray gun.**

With original WAGNER accessories and spare parts, you have the guarantee that all safety regulations are fulfilled.

4. Description/ Scope of delivery



Description/ Scope of delivery (Fig. 1)	
1) Nozzle	2) Air cap (to set the working direction)
3) Union nut	4) Spray jet width adjustment
5) Wall Extra I-Spray spray attachment	6) Material volume adjustment
7) Air volume control	8) Spray gun rear part
9) Air filter cover	10) ON/OFF switch (located on both sides)
11) Trigger	12) Mains lead
13) Container	14) Valve
15) Ventilating hose	16) Stirring rod
17) Feed hopper (2 pcs.)	18) Practice poster
19) Lubricating grease*	

* This is inside the container: remove it before starting operations!

5. Field of application

Many different coating substances can be processed with the W 575.

A different spray attachment must be used, depending on the coating substance:

Coating Materials	Spray attachment
Interior and exterior water based acrylic wall, ceiling and fence paints, primers and undercoats.	Wall Extra I-Spray  

6. Coating Materials Suitable for Use

Interior and exterior water based acrylic wall, ceiling and fence paints, primers and undercoats.

The following materials can only be processed with optional accessories:

Water and oil based stains, lacquers, clear finishes and wood preservatives.

7. Coating Materials Not Suitable for Use

Materials that contain highly abrasive components, plaster, facade paint, caustic solutions and acidic coating substances. Flammable materials.

8. Preparation of the workplace (for interior wall paint)



Sockets and plugs must be masked. Risk of an electric shock as a consequence of sprayed material entering the socket!



Mask all the areas and objects that are not to be spray painted, or remove them from the work area. No liability is assumed for damage due to overspray. Silicate paint corrodes glass and ceramic surfaces upon contact! All such surfaces must therefore be completely covered.



Pay attention to the quality of the adhesive tape used. Do not use excessively strong adhesive tape on wallpaper and painted surfaces, in order to avoid damaging these surfaces when removing the tape. Remove adhesive tape slowly and evenly; do not use jerky movements. Do not leave adhesive tape on surfaces any longer than necessary, in order to minimise the possibility of residues when removing. Also observe the adhesive tape manufacturer's instructions.

9. Preparation of the Coating Material

- Mix the material well in the original container. When using interior wall paint, an agitator is recommended.



Flexio Elite has been developed for use with all conventional paints in their undiluted form. If the surface is smooth and the paint you are using is very thick and gel-like, dilute it by 10%. Dilution can be necessary if the atomisation is coarse or if the flow rate is too low even at the maximum setting.

Detailed information about the various materials and the maximum permitted dilution can be found on the manufacturers' technical data sheets (e.g. available on the Internet).



Spray material that is at least at room temperature provides a better spray result.

10. Start-up

Before connecting to the mains supply, be sure that the supply voltage is identical with the value given on the rating plate.

- Unscrew the container from the spray gun.
- Aligning suction tube. (Fig. 2)
If the suction tube is positioned correctly, the container contents can be sprayed without almost any residue.
When working on lying objects: Turn the suction tube forwards. (Fig. 2 A)
Spraying work when working on overhead objects: Turn the suction tube rearwards. (Fig. 2 B)
- Place the container on a paper base and pour in the prepared coating substance with the aid of the feed hopper included in the scope of supply (Fig. 1, 17). Screw the container tightly onto the spray gun.
- Connect the front part with the rear part of the gun (Fig. 3).
- Switch the unit on (Pos. I) using the ON/OFF switch (fig. 4, 1).
- Adjust the spray setting on the spray gun.



The enclosed practice poster is ideal for familiarising yourself with operation of the spray gun. After trying out the sprayer using the poster, it makes sense to test it further on cardboard or a similar surface in order to find out the right flow rate of paint and air for the best spray pattern. Detailed information about these settings can be found in chapter 11-14.

11. Selecting the Spray Setting



WARNING! Danger of injury! Never pull the trigger guard while adjusting the air cap.

2 different spray jet shapes can be set by turning the air cap (fig. 5, 1)



Tighten the union nut (Fig. 5, 2) fully so that no paint is able to penetrate the device. Check regularly whether the union nut has worked loose during operation.

Fig. 6 A = vertical flat jet → for horizontal surfaces

Fig. 6 B = horizontal flat jet → for vertical surfaces

Use the red adjustment lever to also switch between a wide (▷) and a narrow (▷) spray jet.

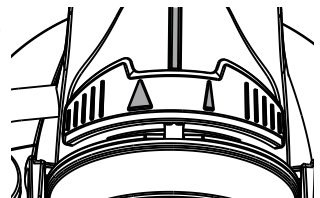

12. Adjusting the Material Volume

The volume of material can be set by turning the material volume control (Fig. 7, 1) in steps from 1 (minimum) to 12 (maximum).

13. Setting the Amount of Air (Fig. 8)



Depending on the viscosity of the material to be sprayed and the finish of the object to be coated, it may be advisable to vary the amount of air. Very low viscosity materials, such as watery glazes do not have to be atomised with the maximum amount of air. In this case it is advisable to reduce the amount of air and thus minimize the spray vapour.

This also applies for the use of the Detail and Corner&Reach spray attachment (accessory).

Turn the air quantity regulator (fig. 8, 1) until the level you want is above the arrow.

thin paint → Level min to 6

thick paint (e.g. interior wall paint) → Level 6 to max

14. Spray Technique



The spray result depends heavily on the smoothness and cleanliness of the surface to be sprayed. Therefore the surface should be carefully prepared and kept free of dust.

- Cover all surfaces not to be sprayed.
- Cover screw threads or similar parts of the target object.



Important: Start at the edge of the area to be sprayed. Start the spray movement first of all, and then press the trigger. Avoid interruptions within the area to be sprayed.

- The spray movement should come from the arm, not just from the wrist. This ensures that a uniform distance is maintained between the spray gun and the spray surface during the spray operation. Select a distance of 5 - 15 cm, depending on the desired spray jet width. When you are using interior wall paint, the distance should be about 20-30 cm (approx. one stirring rod in length).

Fig. 9 A/ 9 B: **CORRECT** Even distance to the object.

Fig. 9 C: **INCORRECT** An uneven distance will result in uneven paint application.

- Move the spray gun evenly cross-wise or up-and-down, depending on the spray pattern setting.
- An even movement of the spray gun results in an even surface quality.



Important: Wipe off the nozzle and air cap regularly to make sure they do not get blocked. If taking a break during spraying, paint will dry over the nozzle. Simply scrape off any dry paint before commencing again.

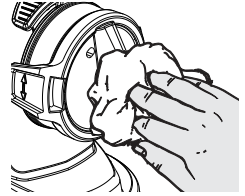

"Cross spray" when using paint with a poor covering capacity or if the surface is highly absorbent (Fig. 10).

- Interior wall paint in strong colour shades should be applied at least twice (allow first paint coat to dry first). This will ensure good coverage.

15. Interruption of Work

- Turn the machine off.
- Put the machine down only on a level, clean surface. Otherwise the machine could tip over!
- During longer breaks, vent the container by briefly opening and then closing it again.
- Clean nozzle openings after an interruption in operation.
- When processing 2-component varnishes, clean the device immediately.

16. Taking Out of Operation and Cleaning

Proper cleaning is the prerequisite for problem-free operation of the paint application device. No warranty claims are accepted in case of improper or no cleaning.



Never hold the spray gun rear part under water or immerse it into liquids. Clean the housing only with a moistened cloth.

- 1) Turn the machine off. Vent the container in case of longer breaks and after the work has been terminated. This can be done by briefly turning open and then closing the container or by pulling the trigger guard and letting the paint into the original paint container.
- 2) Divide the spray gun. Press the hook (Fig. 3 b "click") slightly downwards. Turn the gun front part and gun rear part against each other and take them apart.
- 3) Unscrew the container. Empty any remaining coating material back into the material tin.
- 4) Preclean the container and feed tube with a brush. Clean the ventilating bore (Fig. 11, 1).
- 5) Pour water or solvent into the container. Screw the container back on.
Do not use flammable materials for cleaning purposes.
- 6) Assemble the gun again (Fig. 3).
- 7) Turn on the machine and spray the water or solvent into a container or a cloth.
- 8) Repeat the above procedure until the water or solvent emerging from the nozzle is clear.

- 9) Turn off the machine and remove the plug.
- 10) Divide the spray gun. Press the hook (Fig. 3 b "click") slightly downwards. Turn the gun front part and gun rear part against each other and take them apart.

17. Cleaning the Wall Extra I-Spray spray attachment

- 1) Screw of the container and empty it. Pull out the suction tub with container seal.

CAUTION! Never clean seals, diaphragm and nozzle or air holes of the spray gun with metal objects. The ventilation hose and diaphragm are only solvent-resistant to a limited extent. Do not immerse in solvent, only wipe.

- 2) **The unit may only be operated with an integer diaphragm (Fig. 12, 3).** If any paint has penetrated to the ventilation hose, check and clean the membrane (see the Maintenance chapter).
- 3) Move the air cap (Fig. 13, 1) to the vertical position for easier removal and lift it off.
- 4) Unscrew the union nut (fig. 13, 2). Clean the air cap (1) and nozzle (3) with a brush and solvent or water.



Attention! Never remove the red nozzle seal from the nozzle. If the nozzle seal is either missing or damaged liquids can enter the device and increase the risk of an electric shock.

- 5) Clean the outside of the spray gun and container with a cloth soaked in solvent or water.
- 6) Assemble the parts again (see "Assembly").

Assembly



Attention! Never operate the device if the nozzle seal is either damaged or missing. If the nozzle seal is either missing or damaged liquids can enter the device and increase the risk of an electric shock.

- 1) Check the nozzle seal (fig. 14, 4) in the nozzle.
- 2) Screw the union nut (Fig. 15, 2) onto the gun and tighten it.



Tighten the union nut (Fig. 15, 2) fully so that no paint is able to penetrate the device.

- 3) Engage the air cap (Fig. 16, 1) with the union nut. **Check if the air cap has properly locked into place on both sides. (Fig. 16, 2)**
- 4) Place the container seal from below on the suction tube and slide it over the collar, while turning the container seal slightly.
- 5) Insert the suction tube with container seal in the gun body.

In order to mount the gun more easily apply lubricating grease (enclosed) liberally to the O-ring at the gun front part. (Fig. 18, 3)

18. Maintenance

Air filter



WARNING! Never operate the machine without the air filter; dirt could be sucked in and interfere with the function of the machine. Check the air filter after each use for contaminants. Disconnect plug before changing parts.

- 1) Press both locks (Fig. 17, 1) and remove the filter cover.
- 2) Remove the air filter (2) and replace depending on contamination.
- 3) Click the filter cover in place again.

Ventilating hose / Valve

- 1) Pull the ventilating hose (Fig. 12, 1) at the top from the gun body. Screw off the valve cover (2). Remove the diaphragm (3). **Carefully clean all parts or replace in the event of damage.**
- 2) Place the diaphragm (Fig. 12, 3) **with the pin facing upwards** on the bottom section of the valve. Also see the marking on the gun body.
- 3) Place on the valve cover (Fig. 12, 2) and screw it closed.
- 4) Place the ventilating hose (Fig. 12, 1) on the valve cover and on the nipple at the gun body.

19. Spare Parts

Spare Parts List Wall Extra I-Spray spray attachment (Fig. 18)

Pos.	Designation	Order No.
	Wall Extra I-Spray spray attachment complete with 1300 ml container	2361 746
1	Air cap	2382 753
2	Union nut and nozzle	2382 751
3	O-ring of spray attachment	2362 875
4	Ventilating hose, valve cover, diaphragm	2382 754
5	Suction tube	2389 021
6	Container seal	2389 023
7	Container with cover 1300 ml (only for Wall Extra I-Spray spray attachment)	2305 155

Spare Parts List Flexio Elite (Fig. 19)

Pos.	Designation	Order No.
1	Air filter cover	2397 458
2	Air filter set	2397 460
3	Stirring rod	2304 419
	Lubricating grease (no fig.)	2315 539

20. Accessories

Wagner's unique Click & Paint System means additional spray attachments can be purchased to suit a variety of different projects and surfaces.

Further information about the range of suitable accessories can be found at www.wagneraustralia.com.au

21. Correction of Malfunctions

Problem	Cause	Remedy
No coating material emerges from the nozzle	<ul style="list-style-type: none"> • Device not switched on • Nozzle clogged • Feed tube clogged • Material quantity too small • Feed tube loose • No pressure build-up in container • Ventilating bore (Fig. 11, 1) clogged 	<ul style="list-style-type: none"> • Press the ON/OFF switch on the side of the device • Clean • Clean • Increase the quantity of material • Insert • Tighten container • Clean
Coating material drips from the nozzle	<ul style="list-style-type: none"> • Nozzle loose • Nozzle worn • Nozzle seal is missing or worn • Coating material assembly at air cap, nozzle or needle 	<ul style="list-style-type: none"> • Tighten • Change • Change • Clean
Atomisation too coarse	<ul style="list-style-type: none"> • Coating material too thick • Material volume too large • Nozzle clogged • Air cap assembled incorrectly • Air filter heavily soiled • Too little pressure build-up in container • Amount of air too low 	<ul style="list-style-type: none"> • Dilute • Reduce the material volume • Clean • Snap air cap properly into place (fig. 16, 2) • Change • Tighten container • Increase air quantity
Spray jet pulsates	<ul style="list-style-type: none"> • Coating material in container running out • Air filter heavily soiled • Nozzle seal is missing or worn 	<ul style="list-style-type: none"> • Refill • Change • Change
Coating material causes "paint tears"	<ul style="list-style-type: none"> • Too much coating material applied. 	<ul style="list-style-type: none"> • Reduce the material volume

Problem	Cause	Remedy
Too much fog of coating material (Overspray)	<ul style="list-style-type: none"> Distance to the object too large Too much coating material applied Amount of air too high 	<ul style="list-style-type: none"> Reduce distance Reduce the material volume Decrease air quantity
Paint in the ventilating hose	<ul style="list-style-type: none"> Diaphragm soiled Diaphragm defective 	<ul style="list-style-type: none"> Clean the diaphragm Replace the diaphragm
Poor covering capacity on the wall	<ul style="list-style-type: none"> Spray material is too cold Highly absorbent surface or paint with poor covering capacity Distance too large 	<ul style="list-style-type: none"> The material you are spraying should be at room temperature Cross spray (Fig. 10) Closer to the object

22. Technical Data

Technical Data	
Max. viscosity (Interior wall paint/Wall Extra I-Spray spray attachment):	4000 mPas
Power source:	240 V~, 50 Hz
Power consumption:	630 W
Atomizing output:	200 W (max)
Max. flow rate (Interior wall paint/Wall Extra I-Spray spray attachment):	500 ml/min
Protection Class:	I
Sound pressure level*:	79 dB (A); Uncertainty K = 4 dB
Sound pressure output*:	90 dB (A); Uncertainty K = 4 dB
Oscillation level*:	< 2.5 m/s ² ; Uncertainty K = 1.5 m/s ²
Weight:	1.7 kg

* Measured in accordance with EN 60745-1

Information about the oscillation level

The specified oscillation level has been measured according to a standard test procedure and can be used to compare against electric tools.

The oscillation level is also for determining an initial assessment of the vibrational strain.

Attention! The vibration emission value can differ from the specified value when the electric tool is actually in use, depending on how the electric tool is being used. It is necessary to specify safety measures to protect the operating personnel. These measures

are based on an estimated shutdown during the actual conditions of use (all parts of the operating cycle are taken into consideration here, for example periods when the electric tool is switched off, and, when it is switched on but running without any load).

23. Environmental protection



The device and all accessories and packaging have to be recycled in an environmentally friendly manner. Do not dispose of the appliance with household waste. Support environmental protection by taking the appliance to a local collection point or obtain information from a specialist retailer. Leftover paint and solvents may not be emptied into drains, the sewage system or disposed of as household rubbish. It has to be disposed of separately as special waste. Please pay special attention to the instructions on the product packaging.

24. Important Note regarding Product Liability!

According to an EU directive, the manufacturer is only liable without limitation for faults in the product if all parts come from the manufacturer or have been approved by the manufacturer and have been mounted to the device and are operated properly. If third-party accessories or spare parts are used, the manufacturer is exonerated wholly or partly from his/her liability if use of the third-party accessories or spare parts have caused a defect in the product.

3+1 years guarantee

The guarantee runs for three years, counting from the date of sale (sales slip). The guarantee is extended by a further 12 months if the device is registered online within 4 weeks of the purchase at www.wagner-group.com/3plus1. Registration is only possible if the buyer is in agreement with the data being stored that is entered during registration. The guarantee covers and is restricted to free-of-charge rectification of faults which are demonstrably attributable to the use of faulty materials in manufacture, or assembly errors; or free-of-charge replacement of the defective parts. The guarantee does not cover incorrect use or commissioning or fitting or repair work which is not stated in our operating instructions. Wearing parts are also excluded from the guarantee. The guarantee excludes commercial use. We expressly reserve the right to fulfil the guarantee. The guarantee expires if the tool is opened up by persons other than WAGNER service personnel. Transport damage, maintenance work and loss and damage due to faulty maintenance work are not covered by the guarantee. Under any guarantee claim, there must be proof of purchase of the tool through submission of the original receipt. Wherever legally possible, we exclude all liability for injury, damage or consequential loss, especially if the tool has been used for a purpose other than that stated in the operating instructions, commissioned or repaired other than in accordance with our operating instructions or if repairs are performed by someone who is unqualified. We reserve the right to perform any repairs in excess of those stated in our operating instructions. In case of guarantee or repair, please refer to your point of sale.

EU Declaration of conformity

We declare under sole responsibility that this product conforms to the following relevant stipulations:

2006/42/EC, 2014/30/EU, 2011/65/EU, 2012/19/EU

Applied harmonised norms:

EN 60745-1, EN 50580, EN 62233, EN 55014-1, EN 55014-2, EN 61000-3-2, EN 61000-3-3

D**J. WAGNER GMBH**

Otto-Lilienthal-Str. 18
88677 Markdorf
T +49 0180 - 55 92 46 37
F +49 075 44-505 11 69

SK**E-CORECO SK S.R.O.**

Kráľovská ulica 8/7133
927 01 Šala
T +42 1948882850
F +42 1313700077

CZ**E-CORECO S.R.O.**

Na Roudné 102
301 00 Plzeň
T +42 734 792 823
F +42 227 077 364

F**WAGNER FRANCE S.A.R.L.**

12 Avenue des Tropiques
Z.A. de Courtaboeuf
91978 Les Ulis Cedex
T +33 0825 011 111
F +33 (0)1 69 81 72 57

GB**WAGNER SPRAYTECH (UK) LTD**

Innovation Centre
Silverstone Park
Silverstone
Northants NN12 8GX
T + 44 (0) 1327 368410

DK**DVA A/S**

Marielundvej 48 C
2730 Herlev
T +45 70 234 239

DK**ORKLA HOUSE CARE DANMARK A/S**

Stationsvej 13
3550 Slangerup
Danmark
T +45 47 33 74 00
F +45 47 33 74 01

NOR**ORKLA HOUSE CARE NORGE AS**

Nedre Skøyen vei 26,
PO Box 423, Skøyen
0213 Oslo
T +47 22 54 40 19

PL**PUT WAGNER SERVICE**

ul. E. Imieli 27
41-605 Swietochlowice
T +48/32/346 37 00
F +48/32/346 37 13

S**ORKLA HOUSE CARE AB**

Box 133
564 23 Bankeryd
Sweden
T +46(0)36 37 63 00

ROM**ROMIB S.R.L.**

str. Poligonului nr. 5 - 7
100070 Ploiesti ,judet Prahova
T +40-344801240
F +40-344801239

CH**J. WAGNER AG**

Industriestraße 22
9450 Altstätten
T +41 71 - 7 57 22 11
F +41 71 - 7 57 23 23

E**P****MAKIMPORT
HERRAMIENTAS, S.L.**

C/ Méjico nº 6
Pol. El Descubrimiento
28806 Alcalá de Henares (Madrid)
T 902 199 021 / 91 879 72 00
F 91 883 19 59

AUS**WAGNER SPRAYTECH
AUSTRALIA PTY. LTD.,**

14-16 Kevlar Close
Braeside, VIC 3195
T +61 3 9587 2000
F +61 3 9580 9120

I**FHC SRL**

Via Stazione 94,
26013 Crema (CR)
T 0373 204839
F 0373 204845