



# TITAN®

## OPERATING MANUAL

# HELIX™

## FR 28

AIRLESS, HIGH-PRESSURE  
SPRAYING SYSTEM

WITH SUREFIRE™ HEATING SYSTEM

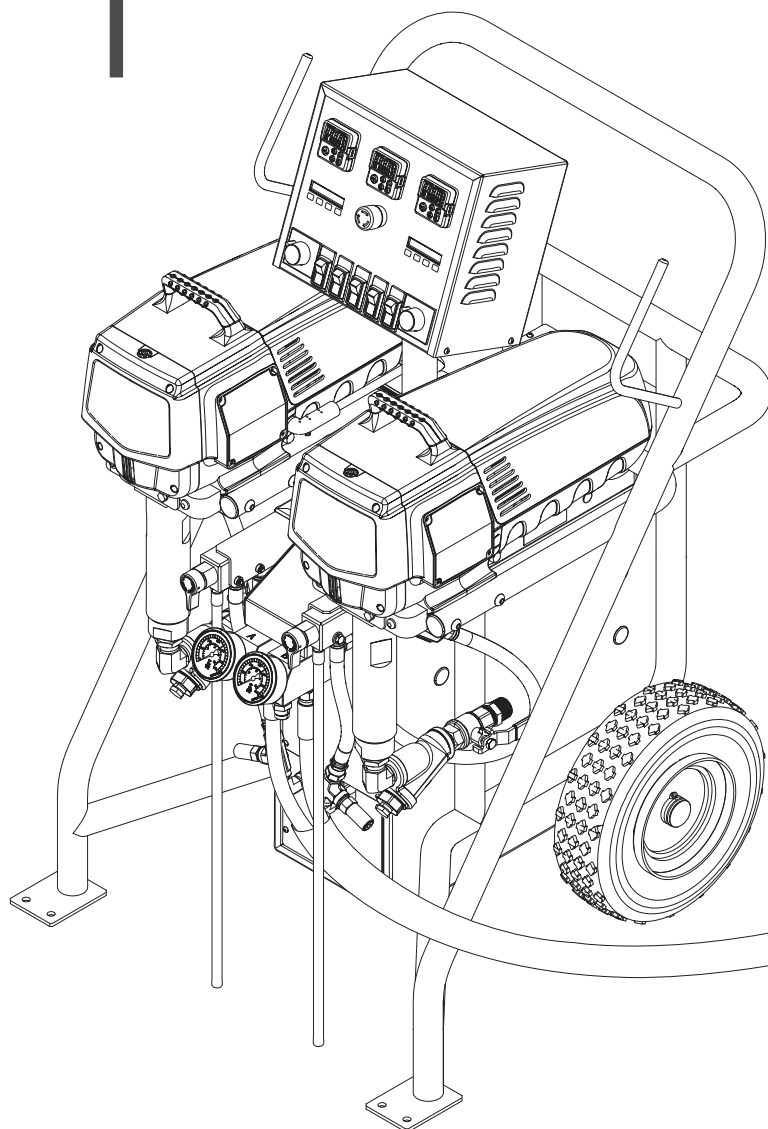

**Models:** 0138010  
0138010 AP  
0138057  
2405634  
2407046

0719 • Form No. 0138874M

# Warning!

**Attention: Danger of injury by injection!**  
Airless units develop extremely high spraying pressures.

**1**

**Never put your fingers, hands or any other parts of the body into the spray jet!**

**Never point the spray gun at yourself, other persons or animals.  
Never use the spray gun without safety guard.**

**Do not treat a spraying injury as a harmless cut. In case of injury to the skin through coating materials or solvents, consult a doctor immediately for quick and expert treatment. Inform the doctor about the coating material or solvent used.**

**2**

**The operating instructions state that the following points must always be observed before starting up:**

1. Faulty units must not be used.
2. Secure the spray gun using the safety catch on the trigger.
3. Ensure that the unit is properly earthed.
4. Check allowable operating pressure of high-pressure hose set and spray gun.
5. Check all connections for leaks.

**3**

**The instructions regarding regular cleaning and maintenance of the unit must be strictly observed.**

**Before any work is done on the unit or for every break in work the following rules must be observed:**

1. Release the pressure from spray gun and hose.
2. Secure the spray gun using the safety catch on the trigger.
3. Switch off unit.
4. Unplug the power cord from the unit.

# Be safety conscious!

<b>1</b>	<b>SAFETY REGULATIONS</b>	<b>4</b>	<b>7</b>	<b>SHUTTING DOWN</b>	<b>25</b>
1.1	Explanation of symbols used	4	7.1	Parking	25
1.2	Isocyanate (ISO) Conditions	6	7.2	Flushing	25
1.3	Electric safety	7			
<b>2</b>	<b>GENERAL DESCRIPTION</b>	<b>8</b>	<b>8</b>	<b>TROUBLESHOOTING</b>	<b>26</b>
2.1	System configurations	8	8.1	Component pump	26
2.2	Clearance diagram	8	8.2	Surefire™ heater block / hose heater controller errors	27
2.3	Electrical / generator requirements	9			
<b>3</b>	<b>SYSTEM DESCRIPTION</b>	<b>10</b>	<b>9</b>	<b>SERVICING</b>	<b>30</b>
3.1	System diagram - without circulation	10	9.1	Replacing the motor assembly	30
3.2	Component description - without circulation	11	9.2	Replacing the gears	31
3.3	System diagram - with circulation	12	9.3	Replacing the transducers	31
3.4	Component description - with circulation	13	9.4	Replacing the PRIME/SPRAY valve	32
3.5	Installing the circulation kit (optional)	13	9.5	Inlet and outlet valves	33
			9.6	Packings	34
			9.7	Electrical schematic (model 0138010 / 2407046)	36/37
<b>4</b>	<b>CONTROL PANEL</b>	<b>14</b>	9.8	Electrical schematic (model 0138057 / 2405634)	38/39
4.1	Surefire™ heater block control	15			
4.2	Surefire™ heated hose temperature control	15			
4.3	Component pump pressure control	16			
4.4	Control Displays	16			
4.5	Control Displays Error Messages	19			
<b>5</b>	<b>SETUP</b>	<b>20</b>			
5.1	Locate the system	20			
5.2	Install the transfer pumps	20			
5.3	Connect the Surefire™ heated hoses	21			
5.4	Connect the electrical cord	22			
5.5	Ground the system	22			
5.6	Lubricate the component pumps	22			
<b>6</b>	<b>OPERATION</b>	<b>23</b>			
6.1	Startup	23			
6.2	Set temperature	23			
6.3	Spraying	24			
6.4	Pressure relief procedure	24			
				<b>SPARE PARTS LISTS</b>	<b>40</b>
				Spare parts list for main assembly	40/41
				Spare parts list for component pump assembly	42/43
				Spare parts list for drive assembly	44/45
				Spare parts list for Surefire™ heater block system	46/47
				Spare parts list for display assembly	48/49
				Spare parts list for fluid section	50/51
				Spare parts list for cart assembly	52
				Spare parts list for PRIME/SPRAY valve assembly	53
				Spare parts list for Surefire™ heater block	54
				<b>WARRANTY</b>	<b>55</b>

# 1 SAFETY REGULATIONS

## 1.1 EXPLANATION OF SYMBOLS USED

This manual contains information that must be read and understood before using the equipment. When you come to an area that has one of the following symbols, pay particular attention and make certain to heed the safeguard.



→ This symbol indicates a potential hazard that may cause serious injury or loss of life. Important safety information will follow.



→ This symbol indicates a potential hazard to you or to the equipment. Important information that tells how to prevent damage to the equipment or how to avoid causes of minor injuries will follow.



→ Danger of skin injection



→ Danger of fire from solvent and spray fumes



→ Danger of explosion from solvent, spray fumes and incompatible materials



→ Danger of injury from inhalation of harmful vapors



→ Danger of injury from burns



→ Danger of injury from electric shock



→ Notes give important information which should be given special attention.



### HAZARD: INJECTION INJURY

Attention: Danger of injury by injection! A high pressure stream produced by this equipment can pierce the skin and underlying tissues, leading to serious injury and possible amputation.

Do not treat a spraying injury as a harmless cut. In case of injury to the skin through coating materials or solvents, consult a doctor immediately for quick and expert treatment. Inform the doctor about the coating material or solvent used.

### PREVENTION:

- NEVER aim the gun at any part of the body.
- NEVER allow any part of the body to touch the fluid stream. DO NOT allow body to touch a leak in the fluid hose.
- NEVER put your hand in front of the gun.
- ALWAYS lock the gun trigger, shut the fluid pump off and release all pressure before servicing, cleaning the tip guard, changing tips, or leaving unattended. Pressure will not be released by turning off the engine. The PRIME/SPRAY valve(s) or pressure bleed valve must be turned to their appropriate positions to relieve system pressure.
- All accessories must be rated at or above the maximum operating pressure range of the sprayer. This includes guns, extensions, and hose.



### HAZARD: EXPLOSION OR FIRE

Solvent and material fumes can explode or ignite. Severe injury and/or property damage can occur.



### PREVENTION:

- Only spray coating materials with a flash point of at least 5 kelvin higher than the set temperature (minimum flash point is 38°C). The flash point is the lowest temperature at which vapors develop from the coating material. These vapors are sufficient to form an inflammable mixture over the air above the coating material.
- Do not use a material or solvent containing halogenated hydrocarbons. Such as chlorine, bleach mildewcide, methylene chloride and trichloroethane. They are not compatible with aluminum. Contact the coating supplier about compatibility of material with aluminum.
- Do not use the unit in work places which are covered by the explosion protection regulations.
- Provide extensive exhaust and fresh air introduction to keep the air within the spray area free from accumulation of flammable vapors.

- Avoid all ignition sources such as static electricity sparks, electrical appliances, flames, pilot lights, hot objects, and sparks from connecting and disconnecting power cords or working light switches.
- Do not smoke in spray area.
- Place sprayer sufficient distance from the spray object in a well ventilated area. Flammable vapors are often heavier than air. Floor area must be extremely well ventilated. The pump contains arcing parts that emit sparks and can ignite vapors.
- The equipment and objects in and around the spray area must be properly grounded to prevent static sparks.
- Use only conductive or earthed high pressure fluid hose. Gun must be earthed through hose connections.
- Power cord must be connected to a grounded circuit (electric units only).
- Follow material and solvent manufacturer’s warnings and instructions. Be familiar with the coating material’s SDS sheet and technical information to ensure safe use.
- Use lowest possible pressure to flush equipment.
- When cleaning the unit with solvents, the solvent should never be sprayed or pumped back into a container with a small opening (bunghole). An explosive gas/air mixture can arise. The container must be earthed.



**HAZARD: HAZARDOUS VAPORS**

Solvents and other materials can be harmful if inhaled or come in contact with body. Vapors can cause severe nausea, fainting, or poisoning.

**PREVENTION:**

- Wear respiratory protection when spraying. Read all instructions supplied with the mask to be sure it will provide the necessary protection.
- All local regulations regarding protection against hazardous vapors must be observed.
- Wear protective eyewear.
- Protective clothing, gloves and possibly skin protection cream are necessary for the protection of the skin. Observe the regulations of the manufacturer concerning coating materials, solvents and cleaning agents in preparation, processing and cleaning units.



**HAZARD: BURN HAZARD**

Certain components of the equipment are heated and become hot during operation.

**PREVENTION:**

- To avoid severe burns and injury, do not touch heated fluid or equipment. Wait until the equipment has completely cooled.



**HAZARD: THERMAL EXPANSION**

Heated fluids, when in confined areas such as spray hoses, can create a rapid rise in pressure due to thermal expansion. Over-pressurization can lead to a rupture and serious injury.

**PREVENTION:**

- During system heating, make sure PRIME/SPRAY valves are set to SPRAY.
- Before each use, check all hoses for cuts, leaks, abrasion or bulging of cover. Check for damage or movement of couplings. Immediately replace the hose if any of these conditions exist. Never repair a spray hose. Replace it with another earthed high-pressure hose.



**HAZARD: HIGH PRESSURE HOSE**

The spray hose can develop leaks from wear, kinking and abuse. A leak can inject material into the skin. Inspect the hose before each use.

**PREVENTION:**

- High-pressure hoses must be checked thoroughly before they are used.
- Replace any damaged high-pressure hose immediately.
- Never repair defective high-pressure hoses yourself!
- Avoid sharp bends and folds: the smallest bending radius is about 20 cm.
- Do not drive over the high-pressure hose. Protect against sharp objects and edges.
- Never pull on the high-pressure hose to move the device.
- Do not twist the high-pressure hose.
- Use only compatible cleaning solutions.
- Lay the high-pressure hose in such a way as to ensure that it cannot be tripped over.



Only use approved original-high-pressure hoses in order to ensure functionality, safety and durability.

**HAZARD: GENERAL**

This product can cause severe injury or property damage.

**PREVENTION:**

- Follow all appropriate local, state, and national codes governing ventilation, fire prevention, and operation.
- Pulling the trigger causes a recoil force to the hand that is holding the spray gun. The recoil force of the spray gun is particularly powerful when a high pressure has been set on the airless pump. When cleaning, set the pressure control to the lowest pressure.
- Use only manufacturer authorized parts. User assumes all risks and liabilities when using parts that do not meet the minimum specifications and safety devices of the pump manufacturer.
- ALWAYS follow the material manufacturer's instructions for safe handling of chemicals.
- Clean up all material and solvent spills immediately to prevent slip hazard.
- Never leave this equipment unattended. Keep away from children or anyone not familiar with the operation of airless equipment.
- Device weighs in excess of 36 kg. Three-person lift is required.
- The device and all related liquids (i.e. hydraulic oil) must be disposed of in an environmentally friendly way.

**1.2 ISOCYANATE (ISO) CONDITIONS**

Important Information Regarding Two-Component Material. Read before using the equipment.

**ISOCYANATE (ISO) CONDITIONS**

- Use only Methyl-diisocyanates (MDI).
- Spraying materials that contain isocyanates (ISO) creates mists, vapors and atomized particulates that are potentially harmful.
- Be familiar with the spray material's SDS in order to understand specific hazards and necessary precautions that are related to the use of spray materials containing isocyanates.
- Provide extensive exhaust and fresh air introduction to keep the air within the spray area free from harmful isocyanate vapors. If sufficient ventilation is not available, a supplied-air respirator must be available to everyone in the work area.
- **AVOID ANY BARE-SKIN CONTACT WITH ISOCYANATES.** To prevent contact with isocyanates, all persons located within the spray area must be wearing the appropriate protective equipment, including chemically impermeable gloves, boots, aprons and goggles.

**MATERIAL IGNITION**

- Some materials may become self-igniting if applied too thickly. Read material manufacturer's warnings and material SDS.

**KEEP SPRAY COMPONENTS SEPARATE**

- Cross-contamination of individual spray materials can result in cured material in fluid lines which can cause severe injury and/or damage to the equipment.
- To prevent cross-contamination of the equipment wetted parts, **NEVER** interchange Component A (isocyanate) parts with Component B (resin) parts.

**MOISTURE SENSITIVITY**

Isocyanates (ISO) are catalysts used in two-component foam and polyurea coatings. ISO will react with moisture (such as humidity) to form small, hard abrasive crystals. These crystals will then contaminate the fluid. Eventually a film will form on the fluid surface and the ISO will begin to gel, increasing in viscosity. Fluid contaminated with partially cured ISO, if used, will reduce spray performance and the overall life of the component wetted parts.



The amount of film formation and the rate of crystalization varies depending upon the blend of ISO, the humidity and the temperature.

**PREVENTION:**

- Always use a sealed container with a desiccant dryer in the vent, or a nitrogen atmosphere. NEVER store ISO in an open container.
- Use ONLY the moisture-proof hoses specifically designed for ISO that are supplied with your system. If new hoses need to be ordered, contact Titan Technical Service.
- Never flush reclaimed solvents through the system. Reclaimed solvents can contain moisture. Always keep solvent containers closed when not being used to prevent moisture contamination.
- Never use solvent on one side if it has been contaminated from the other side.
- Always lubricate threaded parts with ISO pump oil or grease when reassembling.
- Always circulate a hose and pump that contains ISO at least once a week to prevent the ISO from crystalizing.

**CHANGING MATERIALS**



- When changing spray materials, thoroughly flush the equipment multiple times to ensure that it is fully clean.
- Always clean the fluid inlet strainers after flushing.
- Check with your material manufacturer for chemical compatibility.
- Most materials use ISO with Component A, but some use ISO with Component B.
- Epoxies often have amines (hardener) with Component B. Polyureas often have amines with Component B (resin).

**FOAM RESINS WITH 245FA BLOWING AGENT**

Some blowing agents will froth at temperatures above 90° F (33°C) when not under pressure, especially if agitated. To reduce frothing, minimize preheating in a circulation system.

**1.3 ELECTRIC SAFETY**

Electric models must be earthed. In the event of an electrical short circuit, earthing reduces the risk of electric shock by providing an escape wire for the electric current. Connection to the mains only through a special feed point, e.g. through an error protection installation with INF < 30 mA.

	DANGER — Work or repairs at the electrical equipment may only be carried out by a skilled electrician. No liability is assumed for incorrect installation. Switch the unit off. Before all repair work, unplug the power plug from the outlet.
	Danger of short-circuits caused by water ingressing into the electrical equipment. Never spray down the unit with high-pressure or high-pressure steam cleaners.

**OPERATING TEMPERATURE**

This equipment will operate correctly in its intended ambient, at a minimum between +10°C and +40°C.

**RELATIVE HUMIDITY**

The equipment will operate correctly within an environment at 50% RH, +40°C. Higher RH may be allowed at lower temperatures.

Measures shall be taken by the Purchaser to avoid the harmful effects of occasional condensation.

**ALTITUDE**

This equipment will operate correctly up to 2100 m above mean sea level.

**TRANSPORTATION AND STORAGE**

This equipment will withstand, or has been protected against, transportation and storage temperatures of -25°C to +55°C and for short periods up to +70°C.

It has been packaged to prevent damage from the effects of normal humidity, vibration and shock.

## 2 GENERAL DESCRIPTION

The Helix Plural Component System is a dual, high pressure airless sprayer system that can be linked in order to spray multi-component fluids.

### 2.1 SYSTEM CONFIGURATIONS

The Plural Component System is available in the following configuration(s) which is based upon the number of heating elements, hose length, electrical phases and the required power cord (not supplied). Refer to the chart below.

Model	Voltage (phase)	Circuit breaker	Hose Watts	System Watts	# Heating Elements	Heated Hose	Max Flow (gal/min)	Max Fluid Pressure	Cord Specification AWG (mm <sup>2</sup> )
0138010	230V (1)	50A minimum	2200	13200	3	200' (61 m)	2.2	2000 PSI	6 (13.7), 3 wire + ground
0138057	208V (3)	40A minimum	1800	11850	3	200' (61 m)	2.2	2000 PSI	8 (8.0), 3 wire + ground
2405634	208V (3)	40A minimum	1800	11850	3	200' (31 m)	2.2	2000 PSI	8 (8.0), 3 wire + ground
2407046	230V (3)	50A minimum	2200	13200	3	200' (31 m)	2.2	2000 PSI	6 (13.7), 3 wire + ground



The spray gun provided with this system or sold individually is not Intertek approved.

### 2.2 CLEARANCE DIAGRAM





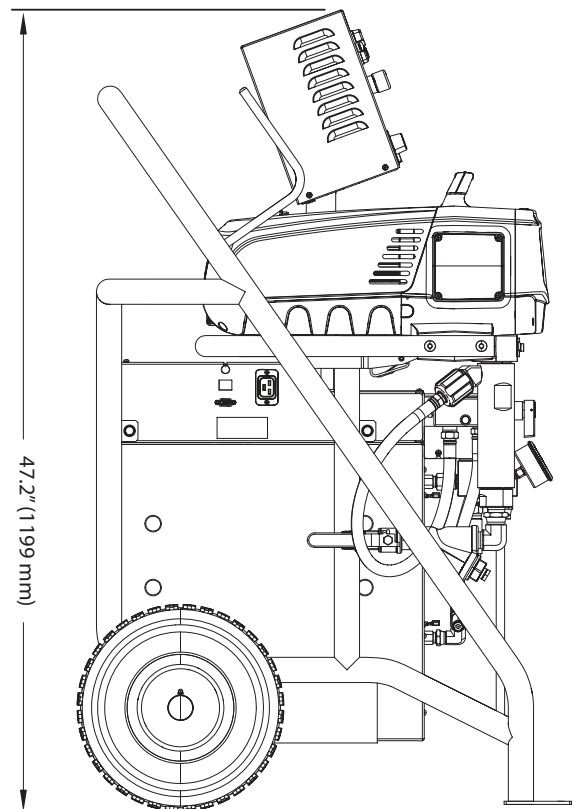
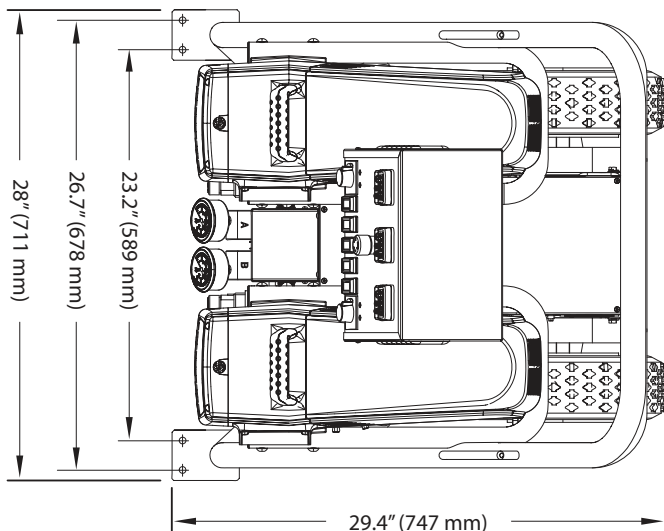

When determining the location of the Helix system, use the diagram below to determine space clearance and mounting hole dimensions.





**2.3 ELECTRICAL / GENERATOR REQUIREMENTS**

	<p>It is recommended that the Helix System be used with a generator. This provides the flexibility with not having to use the public power grid.</p> <p>When connected to the public, low-voltage network, it is possible that an approval of the network operator is required. Check the regulations in your country and contact your network operator before connecting the unit to a public electricity grid.</p>
	<p>The Helix System requires a 208-240V capacity. Make sure the power source is rated to this specification.</p>
	<p>When working at altitudes above 2100m, check the generator manufacturer’s specifications for power loss offset.</p>

 <p>Attention</p>	<p>If powering the Helix system with a generator, make sure the generator has ample power to run the system. An inadequate generator will cause RPM fluctuations in the Component Pump motors during usage and can cause damage.</p>
---	--

Follow the steps below to determining if your generator is able to supply sufficient power to the Helix system.

1. Perform this equation:  

$$\text{System Watts } 13,300 \times 1.25 = \text{kVA (kilovolt / amperes)}$$
2. If your generator’s kVA rating is **higher** than what was determined in the equation above, the generator will be able to power the system.  
  
 If your generator’s kVA rating is **lower** than what was determined in the equation above, the generator WILL NOT be able to power the system. A larger generator is required.

### 3 SYSTEM DESCRIPTION

#### 3.1 SYSTEM DIAGRAM - WITHOUT CIRCULATION

②

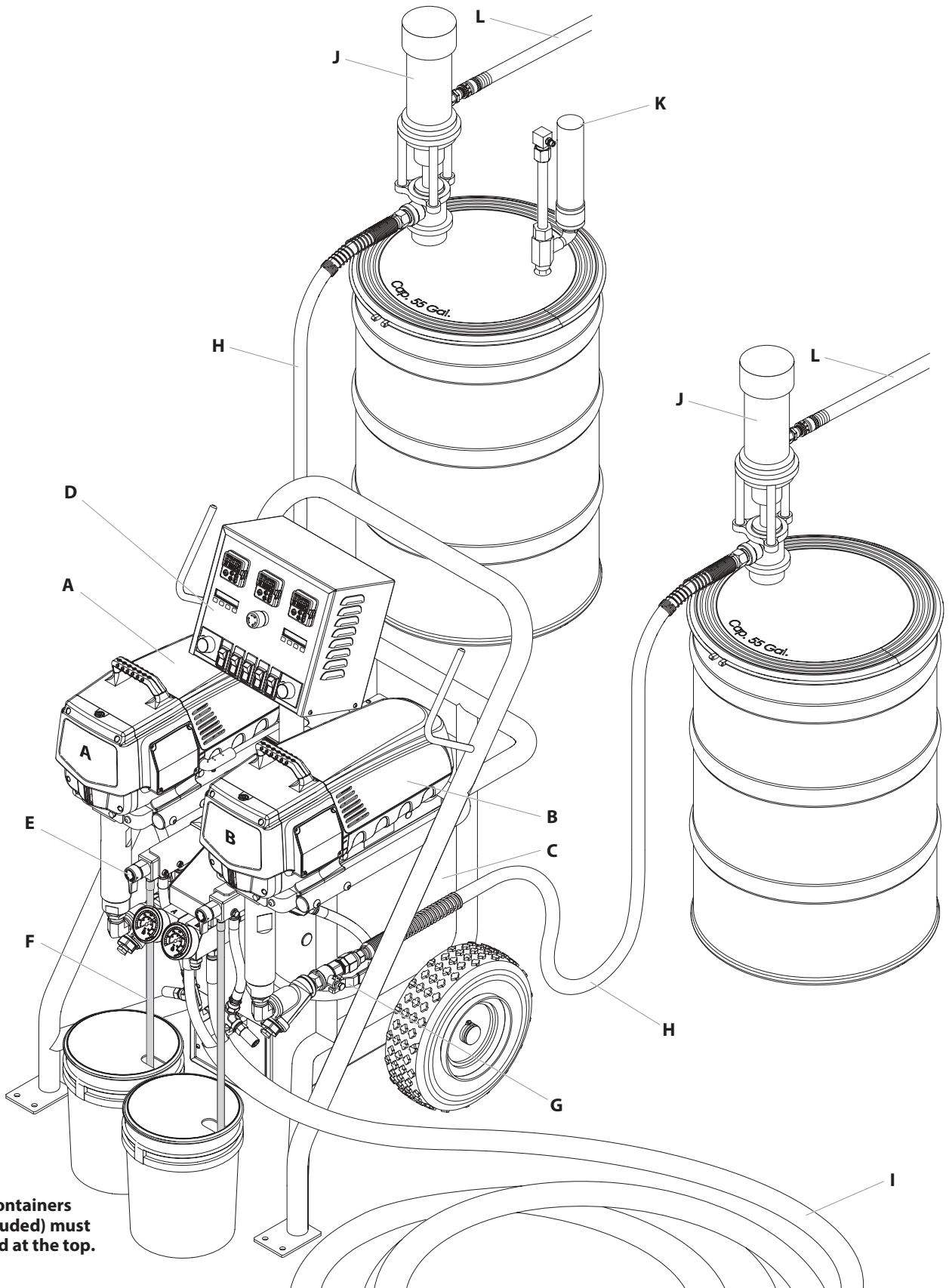

Waste containers  
(not included) must  
be closed at the top.

**3.2 COMPONENT DESCRIPTION - WITHOUT CIRCULATION**

<b>ITEM</b>	<b>DESCRIPTION</b>	<b>FUNCTION</b>
<b>A</b>	Component Pump A	In a two-component system, Component Pump A typically pumps the ISO or activator material.
<b>B</b>	Component Pump B	In a two-component system, Component Pump B typically pumps the resin material.
<b>C</b>	Surefire™ Heater Block	Material flows from the supply containers into the fluid pumps, where the material is pressurized to the desired pressure(s), based on the Control Panel settings. The Surefire™ heater block heats the material on its way to the material pumps.
<b>D</b>	Control Panel	The control panel contains all of the system controls that allow the sprayer to function properly, as well as being the main display panel that gives information about the system.
<b>E</b>	PRIME/SPRAY knob	The PRIME/SPRAY knob directs material to the spray hose when in the SPRAY position and to the prime hoses when in the PRIME position. Turning the PRIME/SPRAY knob will relieve any pressure built up in the system.
<b>F</b>	Prime hoses	When the PRIME/SPRAY knobs are set to PRIME, spray material will circulate into the Component pumps and then out of the prime hoses.
<b>G</b>	Inlet valves	The inlet valves allow material to be drawn from the material containers into the system. They can be turned off in order to prevent material from entering the system.
<b>H</b>	Supply hoses	The two supply hoses deliver fluid from the supply drums to the Component pumps.
<b>I</b>	Dual heated hose	The dual heated hose delivers spray material from the two Component Pumps to the spray gun.
<b>J</b>	Transfer pump	The two transfer pumps pump material from the supply containers, into the supply hoses and then to the Component Pumps. The transfer pumps are powered by an air compressor.
<b>K</b>	Desiccant dryer	The Desiccant dryers remove any moisture that is present in the air pockets left by the removal of material from the supply drums.
<b>L</b>	Transfer pump air hose	The transfer pump air hose delivers air from the compressor to the transfer pumps.

**3.3 SYSTEM DIAGRAM - WITH CIRCULATION**

3

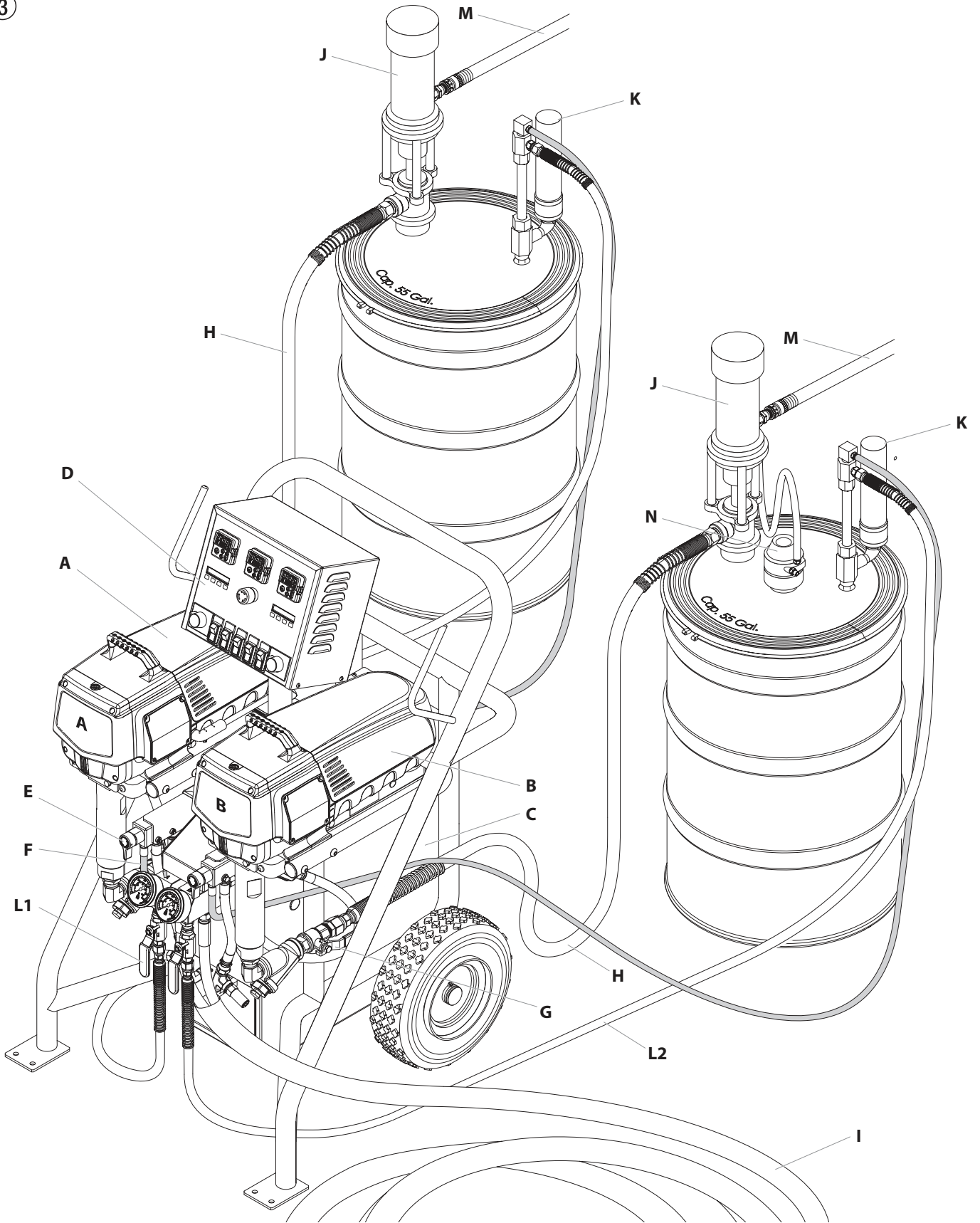

**3.4 COMPONENT DESCRIPTION - WITH CIRCULATION**



This configuration is only possible with the purchase of circulation kit P/N 0138914, sold separately. The parts included in the kit are labeled with an asterisk (\*).

ITEM	DESCRIPTION	FUNCTION
<b>A</b>	Component Pump A	In a two-component system, Component Pump A typically pumps the ISO or activator material.
<b>B</b>	Component Pump B	In a two-component system, Component Pump B typically pumps the resin material.
<b>C</b>	Surefire™ Heater Block	Material flows from the supply containers into the fluid pumps, where the material is pressurized to the desired pressure(s), based on the Control Panel settings. The Surefire™ heater block heats the material on its way to the material pumps.
<b>D</b>	Control Panel	The control panel contains all of the system controls that allow the sprayer to function properly, as well as being the main display panel that gives information about the system.
<b>E</b>	PRIME/SPRAY knob	The PRIME/SPRAY knob directs material to the spray hose when in the SPRAY position and to the prime hoses when in the PRIME position. Turning the PRIME/SPRAY knob will relieve any pressure built up in the system.
<b>F</b>	Prime hoses	When the PRIME/SPRAY knobs are set to PRIME, spray material will circulate into the Component pumps and then out of the prime hoses.
<b>G</b>	Inlet valves	The inlet valves allow material to be drawn from the material containers into the system. They can be turned off in order to prevent material from entering the system.
<b>H</b>	Supply hoses	The two supply hoses deliver fluid from the supply drums to the Component pumps.
<b>I</b>	Dual heated hose	The dual heated hose delivers spray material from the two Component Pumps to the spray gun.
<b>J</b>	Transfer pump	The two transfer pumps pump material from the supply containers, into the supply hoses and then to the Component Pumps. The transfer pumps are powered by an air compressor.
<b>K</b>	Desiccant dryer	The Desiccant dryers remove any moisture that is present in the air pockets left by the removal of material from the supply drums.
<b>L*</b>	Circulation valves / hoses	When open, the circulation valves (L1) allow material to circulate through the heater block and back through the hoses (L2) into the supply containers. This allows the material to be heated more quickly.
<b>M</b>	Transfer pump air hose	The transfer pump air hose delivers air from the compressor to the transfer pumps.
<b>N</b>	Agitator	The agitator stirs the material on the resin (B) side material container.

**3.5 INSTALLING THE CIRCULATION KIT (OPTIONAL)**



The circulation kit is available for separate purchase. Follow the steps below to install it. Refer to section 2.2 for Clearance Diagram.

1. Make sure the system is turned off and depressurized.
2. Remove the two inlet plugs (Fig. 4, item 1) from the bottom of the hose heater manifold. Remove return tubes (2).
3. Thread a shut-off valve (Fig. 3, item L1) from the circulation kit into each of the ports underneath the hose heater manifold. Thread the longer return tubes (Fig. 2, item F) underneath each of the PRIME/SPRAY valve manifolds.
4. Attach a hose to each of the shut-off valves. Run the hoses (Fig. 3, item L2) and return hoses (Fig. 3, item F)

back towards the material containers and thread into their respective ports on the desiccant dryers.

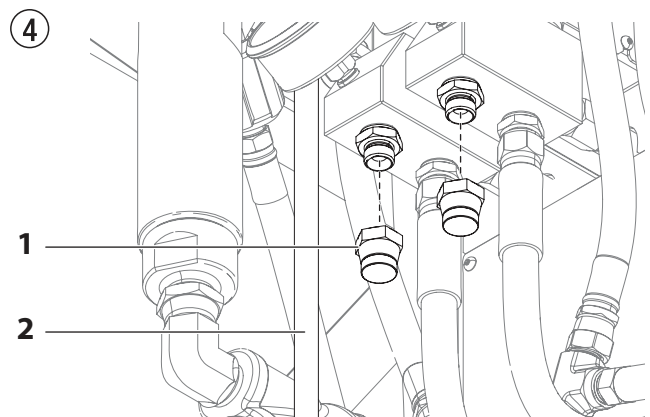

# 4 CONTROL PANEL

The control panel contains all of the system controls that allow the sprayer to function properly, as well as being the main display panel that gives information about the system.

**i** Items 1 - 5 below are duplicated - one for each pump. If they are located on the left side of the panel, they serve the "A" side of the system. If they are located on the right, they serve the "B" side. If it is located in the middle, it serves the entire system.

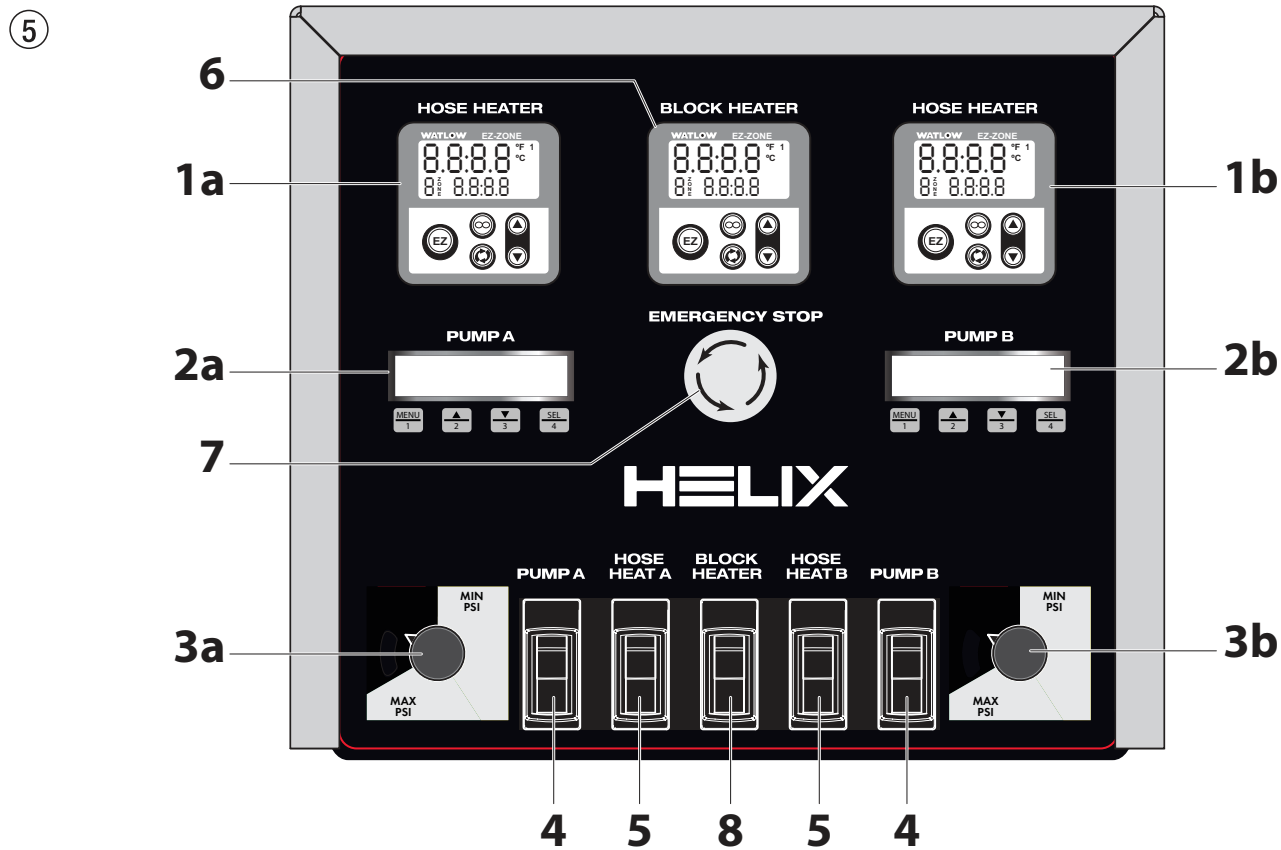

1	Heated hose temperature control	This panel regulates the spray material temperature for the applicable heated hose.
2	Control Displays	The displays show various menu screens that allow the user to customize and monitor pump operation using the function keys (1 - 4).
a	Master controller / A-side independent controller	When the component pumps are linked, the master controller controls both component pumps. When the component pumps are unlinked, this controls Component Pump A only.
b	B-side independent controller	When the component pumps are unlinked, this controls Component Pump B.
3	Component pump pressure control	Adjusts the pump pressure of the applicable Component Pump.
4	ON/OFF switch, Component Pump	This switch turns the applicable Component Pump ON and OFF.
5	ON/OFF switch, hose heater	This switch turns the applicable hose heater ON and OFF.
6	Surefire™ heater block control	This panel regulates the temperature of the Surefire™ heater block
7	Emergency Shutoff	Pushing this button will instantly shut down the system. <b>However, pressing this button WILL NOT depressurize the system. Follow the Pressure Relief Procedure.</b>
8	ON/OFF switch, heater block	This switch turns the heater block ON and OFF

**4.1 SUREFIRE™ HEATER BLOCK CONTROL**

**i** Refer to item 8 in section 4. The block heater control regulates the temperature of spray material as it passes through the heater block, prior to it reaching the heated hoses.

⑥

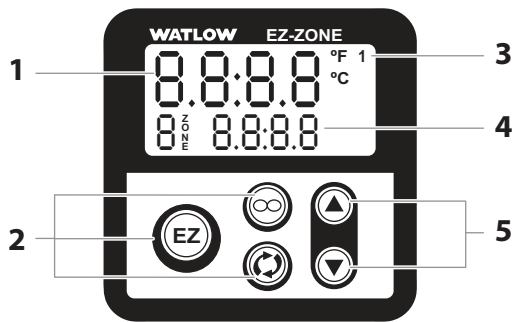

1	Temperature display	Shows actual temperature of the heater block.
2	Programming buttons	These are non-functioning factory programming buttons. Do not use.
3	Power indicator	The flashing or steady "1" indicates sufficient power is being delivered to the system's electrical relay.
4	Temperature setting	Shows the desired temperature of the heater block set by the operator
5	Temperature adjustment	These buttons will increase (▲) or decrease (▼) the temperature of the heater block. The temperature will change in increments of 1°F. Press and hold the button to increase the increments by 10°F.

**i** Refer to section 8.2 to review the controller error messages.

**4.2 SUREFIRE™ HEATED HOSE TEMPERATURE CONTROL**

**i** Refer to item 1 in section 4. The heated hose temperature control maintains the temperature of the spray material once it passes through the heater block and into the heated hoses.

⑦

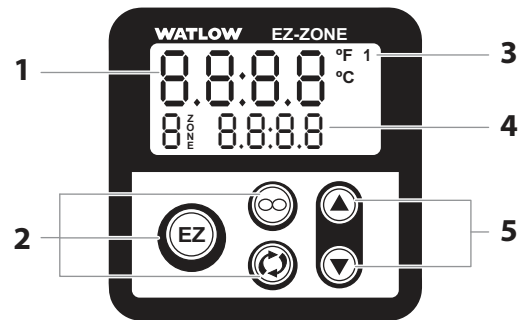

1	Display	Displays the current temperature of the heated hose set
2	Programming buttons	These are non-functioning factory programming buttons. Do not use.
3	Power indicator	The flashing or steady "1" indicates sufficient power is being delivered to the system's electrical relay.
4	Temperature setting	Shows the desired temperature of the heated hoses set by the operator
5	Temperature adjustment	These buttons will increase (▲) or decrease (▼) the temperature of the heated hose set. The temperature will change in increments of 1°F. Press and hold the button to increase the increments by 10°F.

**i** Refer to section 8.2 to review the controller error messages.

**i** Decreased voltage under 230V AC may increase initial heat time.

### 4.3 COMPONENT PUMP PRESSURE CONTROL

**i** Refer to item 2 in section 4. The following items control the pressure of the individual Component Pumps.

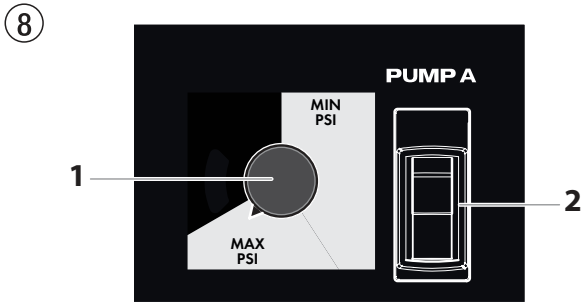

1	Pressure control knob	Adjusts the pump pressure of the applicable Component Pump when unlinked. When Component pumps are linked, the (A) pump pressure control knob will control the pressure of both pumps.
2	Component Pump ON/OFF switch	Switches the Component Pump ON and OFF.

### PRESSURE CONTROL KNOB SETTINGS

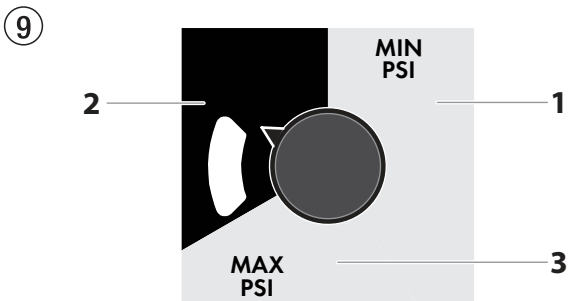

1	Minimum pressure setting
2	Black zone – no pressure generation
3	Maximum pressure setting

### 4.4 CONTROL DISPLAYS

**i** Refer to item 2 in section 4. The graphic below applies to both the Component Pump (A) and Component Pump (B).

The Control Displays increase the functionality of the applicable Component Pump.

It consists of a display (1) and four function keys (2). The display shows various menu screens that allow the user to customize and monitor sprayer operation using the function keys.

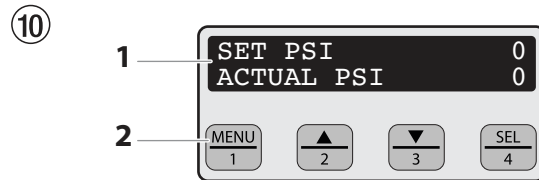

**i** When both component pumps are turned ON, the system will automatically link after 12 seconds. After the pumps are linked together, component pump (B) will be controlled by component pump (A) and the pressure control knob of component pump (B) will be disabled. The pressure set point is managed by the pressure control knob on pump (A).

**i** The pressure control knob overrides the Control Display settings. Anytime the pressure control knob is turned, the sprayer pressure will change accordingly.

### FUNCTION KEYS

The function keys are numbered 1–4. Each key is labeled with an additional function as well.

<b>#1/Menu Key</b>	Pressing the #1 key scrolls through the available menu screens or performs a function described on the active menu screen.
<b>#2/▲ Key</b>	Pressing the #2 key performs a function described on the active menu screen or increases a value.
<b>#3/▼ Key</b>	Pressing the #3 key performs a function described on the active menu screen or decrease a value.
<b>#4/Select Key</b>	Pressing the #4 key selects the active menu screen or performs a function described on the active menu screen.



**MENU SCREENS**

Several menu screens are available for the user to customize and monitor sprayer operation. They include Main Screen, Vis-Comp (Viscosity Compensation)\*, Linked/Unlinked\* Alarm Range\*, Alarm Status\*, Total Cycles\*, Job Cycles\*, Unit Serial #, Timers, Job Timers, Service Time, Security Code\*, and Prime.



Screens noted with an asterisk (\*) are screens that apply to Component Pump (B) only. All other screens apply to both (A) and (B) pumps.

**Main Screen**

The Main Screen is the default screen for the control system at sprayer startup.

SET PSI 0  
ACTUAL PSI 0

Pressing the #2 key switches between PSI, Bar, and MPa units of measure. Press the #1 key to scroll through the remaining menu screens.

**(B) Pump Only** - The "L-" before the "Set PSI" text on the Main Screen indicates that the two Component Pumps are linked.

L-SET PSI 0  
ACTUAL PSI 0



For sprayers equipped with an nine-language Control Display:  
Pressing the #2 key at the Main Screen switches between PSI, Bar and MPa units of measure.  
Pressing the #3 key at the Main Screen changes the language of the text on the display. There are a total of nine languages available. Each time the #1 key is pressed, a different language will appear. The languages, in order of appearance, are: English, Spanish, Dutch, Danish, Swedish, German, French, Italian, and Portuguese.

**VisComp (Viscosity Compensation) Screen\***

The VisComp screen on the (A) pump allows the user to see and/or adjust slight differences in viscosity between the (A) pump material and the (B) pump material.

VISCOMP 1%  
1-NEXT +2 -3

Pressing the #2 key will increase the spraying ratio in increments of 1% (up to 5%). Pressing the #3 key will decrease the spraying ratio in increments of 1% (up to 5%). Pressing the #4 key will increase the ratio by increments of .250.

**Linked/Unlinked Screen\***

The Status Screen shows the link status of the (A) pump and (B) pump.

LINKED  
LINK-2 UNLINK-3

When turning the system on, the two pumps will automatically be linked after 12 seconds, which means the (B) pump is controlled by the (A) pump.

UNLINKED  
LINK-2 UNLINK-3

When the Linked Screen is showing, pressing the #3 key will unlink the two pumps, and the (A) pump and (B) pump will operate independently and the (B) pump control display keys will be enabled.

If the pumps have been unlinked, pressing the #2 key will link the two pumps back together, and the (B) pump will now be controlled by the (A).

**Alarm Range Screen\***

The Alarm Range Screen allows the user to adjust the allowable pressure discrepancy between the (A) and (B) pumps.

ALARM RANGE PSI  
2+ 3- 4^ XXX

Pressing the #2 key will increase the allowable pressure discrepancy by 10 PSI. Pressing the #3 key will decrease the allowable pressure discrepancy by 10 PSI. Pressing the #4 key will toggle between 10 and 100 PSI The range is 300 psi - 1000 psi.

**Alarm Status Screen\***

The Alarm Status Screen allows the user to switch ON or OFF the internal alarm that alerts the user to a non-allowable pressure imbalance.

ALARM ON  
ON-2 OFF-3 EXT-4

Pressing the #2 key will turn the alarm ON. Pressing the #3 key will turn the alarm OFF.



If a pressure imbalance is detected in the system with the alarm status set to ON, the system will automatically shut down and the display will show an Imbalance. Refer to Control Display Error Messages.

**Display Cycles / Volume Screen\***

The Display Cycles / Volume Screen shows the total number of piston cycles a component pump has performed during its lifetime.

DISPLAY	2-CYCLE
1-NEXT	3-VOLUME

Pressing the #2 key will display the cycles screen. This screen shows the total cycles for the life of the unit and cannot be reset.

CYCLES	XXXX
MENU-1	

Pressing the #3 key on the Cycles/ Volume screen will display the volume screen where litres and gallons are displayed. Pressing the #2 key will toggle between litres and gallons. Pressing the 3 key will reset the volume to zero.

LITRES	X
MENU-1	GALLONS-2

LITRES	0
MENU-1	RESET-3

**Job Cycles Screen\***

The Job Cycles Screen shows the total number of piston cycles a component pump performs during a spray job.

JOB CYCLES	
MENU-1	SELECT-4

Pressing the #3 key will reset the cycle count to zero. Pressing the #1 key will bring the control panel back to the Main Screen.

CYCLES	XXXX
MENU-1	RESET-3

**Cycles Per Minute (CPM) Screen**

The Cycles Per Minute (CPM) screen can be accessed from the main menu by pressing the #4 key. This screen will show the speed of the pump while running.

CPM	X
HALL CMD	X

Pressing the #1 key will bring the control panel to the Creep Mode screen.

**Creep Mode Screen**

Creep Mode allows the pump crank shaft to be rotated very slowly. This slow rotation allows the pump piston to be placed at bottom dead center for long term storage and fluid section removal.

CREEP MODE
------------

To access Creep Mode, the display needs to be on the CPM screen and then press the #1 key. Rotate the pressure control knob from Min to Max for the crank shaft to rotate slowly. When the piston is in the desired location, turn the pressure control knob back to Min.

Pressing the #4 key will exit Creep Mode and Pressing the #4 key again will exit the CPM screen.

**Unit Serial # Screen**

The Unit Serial # screen shows the sprayer's serial number.

UNIT SERIAL #	
MENU-1	SELECT-4

To select the Unit Serial # screen, press the #4 key.

SER # XXXXXXXXXXXX
MENU-1

**Timers Screen**

The Timers screen shows the total time the sprayer has been turned on as well as the total time the sprayer has been running (pumping).

TIMERS	
MENU-1	SELECT-4

To select the Timers screen, press the #4 key.

ON TIME	XXXX
RUN TIME	XXXX

**Job Timers Screen**

The Job Timers screen allows the user to reset the "ON TIME" and "RUN TIME" to track time on specific jobs.

JOB TIMERS	
MENU-1	SELECT-4

To select the Job Timers screen, press the #4 key. "JOB ON" screen will appear. Press #3 to reset. Press #1 to continue to "JOB RUN" screen. Press #3 to reset. Press #1 to scroll through the remaining menu screens.

JOB ON	X
MENU-1	RESET-3

JOB RUN	X
MENU-1	RESET-3

**Service Time Screen**

The Service Time screen allows the user to set a service time interval (in hours). Below the set time, the screens shows the current amount of hours on the sprayer since the last activation of the service timer. To select the Service Timer screen, press the #4 key.

SERVICE TIME	
MENU-1	SELECT-4

To set the service time, press the #2 (up) and/or the #3 (down) keys to the desired time (run hours will increase/decrease in increments of 1 for each time you press a key).

SERVICE @	XX
RUN HOURS	XX

When the service time interval is set and met by the run hours, the display will show a "Service Required" screen. The pump will remain functional. To return to the Main Screen, press the #1 key. Doing so will reset the "Service @" and "Run Hours" displayed on the Service Screen back to 0.

**Security Code Screen\***

The Security Code screen allows the user to set a four digit security code to prevent unauthorized use of the sprayer. If a security code has been set, the control system display will ask for the code at startup. If the correct code is entered, the display will show the Main Screen and the sprayer will operate. If the wrong code is entered, the display will continue to ask for the correct code and the sprayer will be disabled. To set or change the security code, press the #2 key.

SECURITY CODE	
MENU-1	CHANGE-2



If the sprayer is new, no security code is set and the Main Screen will appear at startup. When setting a security code for the first time, the "Enter Old Code Number" screen will appear, and you will need to enter "1111".

Enter the old security code number to access the screen that allows the code change. If the wrong code is entered, the display will continue to ask for the correct code and the security code cannot be changed.

ENTER OLD CODE NUMBER

Enter the new security code. Once the new code is entered, the display will automatically ask that the new code be re-entered for verification. If the same new code is re-entered, the display will confirm that the new code has been accepted and return to the Main Screen. If the new code is re-entered incorrectly, the display will return to the "Enter New Code Number" screen and the process will repeat.

ENTER NEW CODE NUMBER XXXX

RE-ENTER NEW NUMBER XXXX

NEW CODE NUMBER ACCEPTED

If you forget or misplace your security code, you can call Titan customer service for assistance.



To inactivate the Anti-Theft Digital Lockout security function, enter "1111" at the "Enter New Code Number" screen (this is the default code that leaves the sprayer unlocked). As a result, the Main Screen will appear at sprayer startup.



If there is no action at any menu screen for 10 seconds, the display will go back to the Main Screen.

## 4.5 CONTROL DISPLAYS ERROR MESSAGES

The following error message screens appear whenever the Control Display detects a problem with the system. Once a problem occurs and the error message appears, the system will shut down.



Before proceeding, follow the Pressure Relief Procedure outlined in this manual. Additionally, follow all other warnings to reduce the risk of an injection injury, injury from moving parts or electric shock. Always unplug the system before servicing!

### Check Transducer Screen

The Check Transducer screen appears when the transducer has become disconnected or is defective. Take the sprayer to a Titan authorized service center for repair.

CHECK TRANSDUCER

### Check Potentiometer Screen

The Check Potentiometer screen appears when the potentiometer has become disconnected or is defective. Take the sprayer to a Titan authorized service center for repair.

CHECK POTENTIOMETER

### Low Voltage Screen

The Low Voltage screen appears when the sprayer shuts down because of low input voltage. Check the power supply and correct the problem. Restart the system.

LOW VOLTAGE

### High Motor Temperature Screen

The High Motor Temperature screen appears when the temperature of the motor has risen too high. Take the sprayer to a Titan authorized service center for repair.

HIGH MOTOR TEMPERATURE

### High Mechanical Load

The High Mechanical Load screen appears when the sprayer shuts down because of high current or when the sprayer goes into current fold back mode. Take the sprayer to a Titan authorized service center for repair.

HIGH MECHANICAL LOAD

### Imbalance Screen

The Imbalance screen appears when there is a non-allowable pressure discrepancy between the (A) and (B) pumps while linked. If an imbalance occurs, turn both pressure control knobs down to Min PSI (Bar) then press the #3 key to unlink each pump. Once the pumps are unlinked, press the #1 key to return to the Main Screen.

IMBALANCE 3-CLEAR

## 5 SETUP

	<p>In order to prevent accidental startup, make sure the system's power cord is not connected during setup, until instructed to do so.</p>
	<p>Make sure the air pressure supply is shut off while connecting any air hoses to the air supply.</p>

### 5.1 LOCATE THE SYSTEM

1. Locate the system on a level surface. Refer to dimensions in section 2.2 for clearance and mounting hole dimensions.
2. Mount in a dry area.
3. For best results, the machine should be bolted into place.

### 5.2 INSTALL THE TRANSFER PUMPS

	<p>The transfer pumps draw material directly from the spray material container to component pumps in the system. The transfer pumps are powered by an air compressor.</p>
--	---

Refer to section 3.1 for the corresponding illustrations to the steps below.

1. Install the transfer pumps into Component A and Component B supply containers.
  - a. With certain exceptions, the "A" component (hardener) should be located on the "A" side of the system.
  - b. With certain exceptions, the "B" component (resin) should be located on the "B" side of the system.

	<p>Consult the spray material's manufacturer if you are unsure about which Component Pump is compatible with each individual spray component.</p>
--	---

2. Seal the container holding Component A material and install the desiccant dryer in the vent hole.
3. If necessary, install an agitator into the Component B material container.
4. Make sure the Component A and Component B inlet valves are in the closed position (handle should be 90° to the valve).

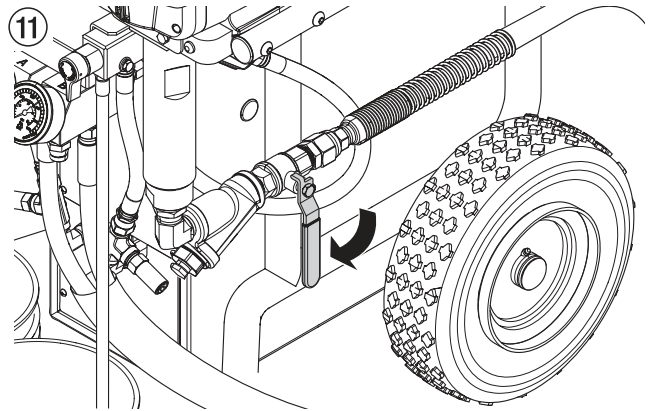



5. Attach the transfer pump air hose to their individual air fittings.
6. Connect the other end of the transfer pump air hose to the powered air pressure supply.

	<p>Do not install shutoff valves downstream of the prime tubes. The PRIME/SPRAY valves function as overpressure relief valves when set to SPRAY.</p>
--	--

**5.3 CONNECT THE SUREFIRE™ HEATED HOSES**

**CONNECT THE HEATED HOSES**

 <p><b>Attention</b></p>	<p>The heated hose assembly and dual whip hose come pre-installed with the system and should not be removed or disassembled unless it is being completely replaced.</p>
	<p>Refer to the Helix Surefire™ Dual Heated Hose Manual included with your system.</p>

1. Attach the JIC fittings (packaged separately with the heated hose set) to their appropriate whip hoses.
  - a. Connect the smaller JIC fitting to the "A" side whip hose.
  - b. Connect the larger JIC fitting to the "B" side whip hose.

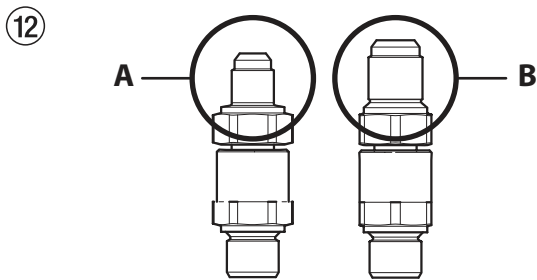

2. Remove the coupling block from the spray gun (refer to the spray gun manual).
3. Close gun manifold valves A and B.

 <p><b>Attention</b></p>	<p>Always close the manifold valves if the system is idle for more than 1 minute under heat and/or pressure. Failure to do so can cause a pressure imbalance which can then lead to a material "crossover" inside the gun, leaving the gun inoperable.</p>
--	--

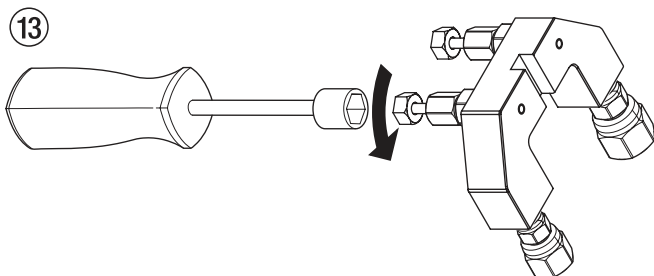

4. Attach the dual heated whip hose to the coupling block.
  - a. Secure the "A" hose to the "A" side of the coupling block.
  - b. Secure the "B" hose to the "B" side (or "R" side) of the coupling block.

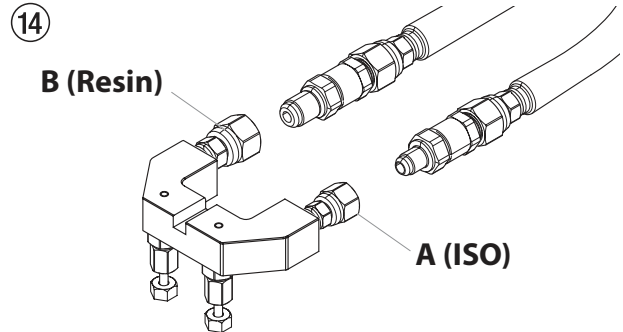



5. Tighten both hose connections with a wrench.

**CONNECT THE SUPPLY HOSES**

1. Make sure the valve handles on the inlet valves for both Component pumps are in the OFF position (see fig. 11).
2. Attach one end of the feed hose to the inlet valve of Component pump A. Repeat for Component pump B with another hose.
3. Connect the other end of each hose to their appropriate transfer pumps (i.e. the "A" hose should run from Component pump A to the transfer pump installed into material supply drum "A").
4. Make sure all connections are wrench tight.
5. Arrange the return hoses:
  - a. For non-circulation configurations (see figure 2, section 3.1), place a waste bucket underneath each of the return hoses.
  - b. For circulation configurations (see figure 3, section 3.3) Attach the return hoses tubes to the dessicant dryers of the appropriate material supply drum (i.e. the "A" return tube for should run from Component pump A to the dessicant dryer installed into material supply drum "A").

### 5.4 CONNECT THE ELECTRICAL CORD

	A 230V power cord is not included with the system. Make sure a grounded, 230V outlet is available in order to power the system.
	It is recommended that the Helix System be used with a generator. This provides the flexibility with not having to use the public power grid. When connected to the public, low-voltage network, it is possible that an approval of the network operator is required. Check the regulations in your country and contact your network operator before connecting the unit to a public electricity grid.

Power Cord Connector Requirements		
Models	0138010 / 2407046	0138057 / 2405634
Connector	Twistlock	Twistlock
AMP	50	50
Number of Poles	3	3
Number of Wires	4	4
Phases	1	3
Voltage	125 / 250 VAC	250 V
Recommended Manufacturer	Pass & Seymour, P/N CS6364	LEVITON P/N CS8364

	If using a generator to power the system, refer to section 2.2 prior to plugging in the power cord.
---	---

1. First plug the adapter end of the supplied power cord into the power cord port located on the side of the block heater.
2. Plug the other end of the supplied power cord into a grounded, 230V outlet.

### 5.5 GROUND THE SYSTEM

	Proper grounding (earthing) is important. The passage of some materials through the nylon fluid hose will build up a static electric charge, which if discharged, could ignite solvent vapors present and create an explosion.
---	--

Component	Grounding Method
System	The system and heated hoses are grounded through the power cord.

Spray Gun	The spray gun is grounded through the whip hose ground wire. Do not spray without using the whip hose.
Fluid Supply Chambers	Follow the local code.
Object being sprayed	Follow the local code.
Waste Containers	Follow the local code. Only use metal containers placed on a grounded surface when flushing the system. Do not place metal waste containers on paper or cardboard surface. A non-conductive surface such as these can interrupt grounding continuity.

	While flushing or relieving system pressure, ground the gun by holding it against the edge of the metal container. Failure to do so may lead to a static electric discharge, which may cause a fire.
---	--

### 5.6 LUBRICATE THE COMPONENT PUMPS

1. Remove the cup cap with a straight-slot screwdriver.
2. Fill the cup reservoir with DOP (Diocetylphthalate) or compatible plasticizer (Fig. 15) until the gauge (1) is showing that it is full.

 <b>Attention</b>	DOP (Diocetylphthalate) or a compatible plasticizer prevents increased wear and tear to the packings and will keep spray material from crystalizing on the fluid section.
---	---

3. Replace cup cap.
4. Press button (2) 2-5 times to prime the dispenser. Press once for every eight hours of usage to lubricate and protect the fluid section.

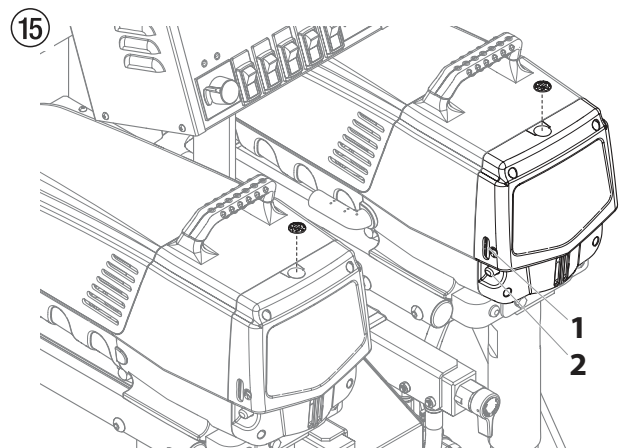

## 6 OPERATION



Prior to startup, make sure the generator has fuel. Running out of fuel will cause electrical fluctuations in the system that could result in damage to the electrical components of the system.

### 6.1 STARTUP

1. If using a generator, make sure the main breaker on the generator is in the OFF position.
2. If using a generator, start the generator. Allow it to run to full power.
3. If using an air compressor to power the transfer pumps, start the compressor, making sure the bleed valve is in the closed position on the compressor.
4. Turn the breaker on the generator to ON. Switch both of the Component Pump ON/OFF switches to ON. (these are the outermost ON/OFF switches located on the control panel).



Do not turn on the block heater or hose heater ON/OFF switches ON yet. Turning the hose heaters on when there is no fluid in the hoses can cause damage to the hoses.

5. Turn the PRIME/SPRAY valves on both of the Component Pumps to SPRAY.
6. Open the fluid inlet valves. Check for leaks.
7. Place the coupling block (with hoses attached) over two separate, grounded waste containers. Make sure the ports on the manifold each aim into a different container.



NEVER mix components A and B during startup. Use two separate grounded waste containers to keep Component A and Component B separate.

16

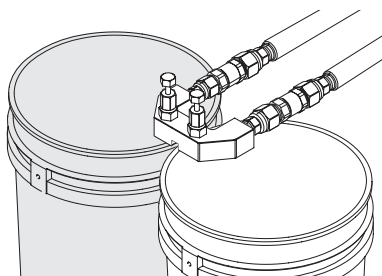

8. While holding the coupling block over the waste containers, slowly open fluid valves A then B. Allow them to remain open until clean, air-free fluid comes from the valves.
9. Close fluid valves A then B.

### 6.2 SET TEMPERATURE



Refer to section 4 to review temperature controls.



Equipment surfaces can become hot. To avoid severe burn injury:

- 1) Do not touch hot fluid or equipment.
- 2) Allow equipment to cool completely before coming into contact with it.
- 3) Wear gloves when dealing with temperatures in excess of 110°F (43°C)

1. Set the temperature of the heater block:
  - a. Switch the heater block ON/OFF switch to ON (this is the ON/OFF switch in the middle of the control panel).
  - b. Using the heater block controls, set the heater block to the desired temperature. Press the (▲) button until the bottom set of numbers (1) shows the desired temperature.

17

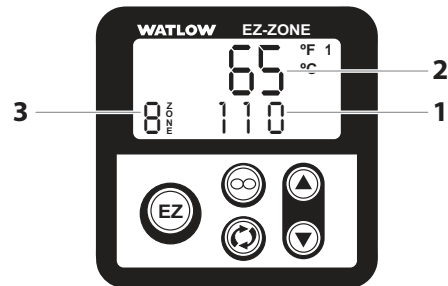

The top number (2) on the heater block displays the actual temperature. When the light (3) goes out, the block heater is sufficiently heated.

2. Set the temperature of the heated hoses (repeat each of the following steps for both A and B hoses):
  - a. Switch the heated hose ON/OFF switches to ON (these are the switches immediately on either side of the heater block switch in the middle of the control panel).
  - b. Using the heated hose controls, set the heated hoses to the desired temperature. Press the (▲) button until the bottom set of numbers (1) shows the desired temperature.
  - c. The temperature settings of the heated hoses can also be adjusted to balance spraying pressures as well as the desired Viscosity Compensation (Vis-Comp).



Adjusting the hose heat should ONLY be a secondary method of achieving the correct Vis-Comp. Use the Vis-Comp Screen on the Control Display first.

### 6.3 SPRAYING



Refer to the safety information in the beginning of this manual for injury prevention guidelines. Refer to the safety and operation instructions of the gun manual.

1. Engage the trigger safety (refer to the spray gun instruction manual).
2. Make sure the valves A / B on the coupling block are closed.
3. Reattach the coupling block (with hoses attached) to the spray gun.
4. Connect the end of the air hose that is closest to the pump to an air supply (the air hose is housed within the velco sheathing that also contains the dual heated hoses). Connect the other end of the air hose to the spray gun. Make sure the air valve on the air hose (if any) is open.
5. Make sure the PRIME/SPRAY valves on the component pumps are set to SPRAY.
6. Verify that the temperature readings are showing the desired temperatures.
7. Verify pressure readings:
  - a. Check pressure gauges mounted on the front of the system, or
  - b. For each component pump, go to the Control Display Main Screen on the control panel.



The pressures shown on either the gauges or the Control Display Screens should be within 200 PSI. If pressure is unbalanced, unlink the pumps, and then adjust the pressure to desired balanced pressure. Once pressure is balanced, re-link the pumps.

8. Open the coupling block valves A and B on the spray gun.



NEVER open the manifold valves on the coupling block or trigger the spray gun if the pressure readings are unbalanced.

9. Disengage the trigger safety (refer to the spray gun instruction manual).
10. Test your spray on a piece of scrap wood or cardboard. Adjust pressure and temperatures as necessary to achieve desired results.



Always close the manifold valves if the system is idle for more than 1 minute under heat and/or pressure. Failure to do so can cause a pressure imbalance which can then lead to a material "crossover" inside the gun, leaving the gun inoperable.

Make sure the Component Pump pressures are balanced prior to opening the manifold valves and resuming spraying.

### 6.4 PRESSURE RELIEF PROCEDURE



Perform the Pressure Relief Procedure when shutting down for any reason.

1. Engage the trigger safety (refer to the spray gun instruction manual).
2. Close the manifold valves A and B on the spray gun.
3. Perform all of these steps on both component pumps:
  - a. Turn the pressure control knob fully counterclockwise to minimum.
  - b. Turn the PRIME/SPRAY knob to PRIME.
4. Disconnect the spray gun air supply line.



## 7 SHUTTING DOWN



It is important to the system's electrical reliability to maintain steady electrical voltage during shutdown. Failure to follow these procedures can cause voltage fluctuations that can damage the equipment and void the warranty.

1. Perform the Pressure Relief Procedure (section 6.4).
2. Turn the block heater ON/OFF switch to OFF (this is the switch located in the center of the control panel).
3. Turn both hose heater A and B ON/OFF switches to OFF (these are the switches on either side of the heater block ON/OFF switch).
4. Switch off the air compressor and any other auxiliary equipment, if being used.
5. Open the bleed valve on the air compressor in order to relieve pressure and remove any water that may have formed in the tank.
6. Turn the Component (A) and Component (B) inlet valve handles to the closed position (handle should be 90° to the valve).
7. Shut down the transfer pumps as required.

### 7.1 PARKING



Perform the following steps on the (A) Component Pump ONLY unless otherwise specified. The following must be done in order to prevent spray material build-up on the (A) side Component Pump fluid section.

1. Turn the pressure control knob to "MIN PSI" setting in the yellow zone.
2. Press the #4 key on the Control Display control panel. The Cycles Per Minute (CPM) screen will appear. Now press the #1 key on the control panel. The Creep Mode screen will now appear.
3. Slowly turn the pressure control knob clockwise to increase the pressure. The crankshaft/slider assembly will begin to move very slowly.
4. Wait until the crankshaft/slider starts moving downward. When it begins its downstroke, turn the Component (A) PRIME/SPRAY valve to SPRAY.
5. When the crankshaft/slider reaches the bottom, dead-center of its stroke, turn the pressure control knob fully counterclockwise. The crankshaft/slider assembly should stop.

6. Press the cup button 6-8 times to lubricate the piston on both (A) and (B) Component Pumps.
7. Turn the ON/OFF switches for both Component Pumps to OFF.
8. Switch the generator OFF. Allow generator dwell time, per the manufacturer recommendations.

### 7.2 FLUSHING



Flush the system in a well-ventilated area. Do not turn on hose heaters or block heater when flushing with flammable solvents.



If the new Isocyanate being introduced is compatible with Polyol, it is not necessary to flush the (A) side.

1. Flush out the old fluid with new fluid, or flush the old fluid with a compatible solvents prior to introducing a new fluid (check with the old fluid manufacturer in order to determine a compatible flushing solvent).
2. Always use the lowest possible pressure when flushing the sprayer. Make sure the Component Pump pressure control knobs are turned as far counterclockwise as possible in the "MIN PSI" yellow zone.
3. Use only moisture-free solvents when flushing the system.

## 8 TROUBLESHOOTING

### 8.1 COMPONENT PUMPS

Problem	Cause	Solution
A. The unit will not run.	<ol style="list-style-type: none"> <li>1. The unit is not plugged in to a power source.</li> <li>2. Tripped breaker.</li> <li>3. The pressure is set too low (pressure control knob set at minimum setting does not supply power to unit).</li> <li>4. Faulty or loose wiring.</li> <li>5. Excessive motor temperature.</li> <li>6. ON/OFF switch is defective.</li> </ol>	<ol style="list-style-type: none"> <li>1. Plug the power cord into a grounded, 230V outlet.</li> <li>2. Reset the breaker.</li> <li>3. Turn the pressure control knob clockwise to supply power to the unit and increase the pressure setting.</li> <li>4. Inspect or take to an authorized service center.</li> <li>5. Allow motor to cool.</li> <li>6. Replace the ON/OFF switch.</li> </ol>
B. The unit will not build or maintain pressure.	<ol style="list-style-type: none"> <li>1. The pressure control knob is not set properly.</li> <li>2. Material flows from the return hose when the PRIME/SPRAY valve is in the SPRAY position.</li> <li>3. Air leak in material feed hoses.</li> <li>4. There is external fluid leak.</li> <li>5. There is an internal fluid section leak (packings are worn and/or dirty, valve balls are worn).</li> <li>6. Worn valve seats</li> <li>7. Motor powers but fails to rotate</li> <li>8. Transfer pumps not supplying material.</li> </ol>	<ol style="list-style-type: none"> <li>1. Turn the pressure control knob clockwise to increase the pressure setting.</li> <li>2. Clean or replace the PRIME/SPRAY valve.</li> <li>3. Check the inlet valve / feed hose connection. Tighten or wrap the threads with Teflon tape.</li> <li>4. Check for external leaks at all connections. Tighten connections, if necessary.</li> <li>5. Clean the valves and service the fluid section following the steps in section 9.5 and 9.6 in this manual.</li> <li>6. Reverse or replace the valve seats following the steps in section 9.5 and 9.6 in this manual.</li> <li>7. Take unit to a authorized service center.</li> <li>8. Check air supply and valves, or service the transfer pumps.</li> </ol>
C. Fluid leakage at the upper end of the fluid section.	<ol style="list-style-type: none"> <li>1. The upper packings are worn.</li> <li>2. The piston rod is worn.</li> </ol>	<ol style="list-style-type: none"> <li>1. Repack the pump following the steps in section 9.5 and 9.6 in this manual.</li> <li>2. Replace the piston rod following the steps in section 9.5 and 9.6 in this manual.</li> </ol>



**8.2 SUREFIRE™ HEATER BLOCK / HOSE HEATER CONTROLLER ERRORS**

<b>Problem</b>	<b>Cause</b>	<b>Solution</b>
<p>A. Alarm will not clear or Reset with keypad or digital input.</p>	<ol style="list-style-type: none"> <li>1. Alarm latching is active</li> <li>2. Alarm set to incorrect output</li> <li>3. Alarm is set to incorrect source</li> <li>4. Sensor input is out of alarm set point range</li> <li>5. Alarm set point is incorrect</li> <li>6. Alarm is set to incorrect type</li> <li>7. Digital input function is incorrect</li> </ol>	<ol style="list-style-type: none"> <li>1. Reset alarm when process is within range or disable latching</li> <li>2. Set output to correct alarm source instance</li> <li>3. Set alarm source to correct input instance</li> <li>4. Correct cause of sensor input out of alarm range</li> <li>5. Set alarm set point to correct trip point</li> <li>6. Set digital input function and source instance</li> </ol>
<p>B. Alarm will not activate output.</p>	<ol style="list-style-type: none"> <li>1. Alarm silencing is active</li> <li>2. Alarm blocking is active</li> <li>3. Alarm is set to incorrect output</li> <li>4. Alarm is set to incorrect source</li> <li>5. Alarm set point is incorrect</li> <li>6. Alarm is set to incorrect type</li> </ol>	<ol style="list-style-type: none"> <li>1. Disable alarm silencing, if required</li> <li>2. Disable alarm blocking, if required</li> <li>3. Set output to correct alarm source instance</li> <li>4. Set alarm source to correct input instance</li> <li>5. Set alarm set point to correct trip point</li> <li>6. Set alarm type to correct type</li> </ol>
<p>C. Alarm Error. Alarm status cannot be determined due to a lack of sensor input.</p> <p>ALE1 ALE2 ALE3 ALE4</p>	<ol style="list-style-type: none"> <li>1. Sensor improperly wired or open</li> <li>2. Incorrect setting of sensor type</li> <li>3. Calibration corrupt</li> </ol>	<ol style="list-style-type: none"> <li>1. Correct wiring or replace sensor</li> <li>2. Match setting to sensor used</li> <li>3. Check calibration of controller</li> </ol>
<p>D. Alarm Low. Sensor input below low alarm set point.</p> <p>ALL1 ALL2 ALL3 ALL4</p>	<ol style="list-style-type: none"> <li>1. Temperature is less than alarm set point</li> <li>2. Alarm is set to latching and an alarm occurred in the past</li> <li>3. Incorrect alarm set point</li> <li>4. Incorrect alarm source</li> </ol>	<ol style="list-style-type: none"> <li>1. Check cause of under temperature</li> <li>2. Clear latched alarm</li> <li>3. Establish correct alarm set point</li> <li>4. Set alarm source to proper setting</li> </ol>
<p>E. Alarm High. Sensor input above high alarm set point.</p> <p>ALH1 ALH2 ALH3 ALH4</p>	<ol style="list-style-type: none"> <li>1. Temperature is greater than alarm set point</li> <li>2. Alarm is set to latching and an alarm occurred in the past</li> <li>3. Incorrect alarm set point</li> <li>4. Incorrect alarm source</li> </ol>	<ol style="list-style-type: none"> <li>1. Check cause of over temperature</li> <li>2. Clear latched alarm</li> <li>3. Establish correct alarm set point</li> <li>4. Set alarm source to proper setting</li> </ol>
<p>F. Error Input. Sensor does not provide a valid signal to controller</p> <p>ER.,1</p>	<ol style="list-style-type: none"> <li>1. Sensor improperly wired or open</li> <li>2. Incorrect setting of sensor type</li> <li>3. Calibration corrupt</li> </ol>	<ol style="list-style-type: none"> <li>1. Correct wiring or replace sensor</li> <li>2. Match setting to sensor used</li> <li>3. Check calibration of controller</li> </ol>
<p>G. Limit will not clear or Reset with keypad or digital input</p>	<ol style="list-style-type: none"> <li>1. Sensor input is out of limit set point range</li> <li>2. Limit set point is incorrect</li> <li>3. Digital input function is incorrect</li> </ol>	<ol style="list-style-type: none"> <li>1. Correct cause of sensor input out of limit range</li> <li>2. Set limit set point to correct trip point</li> <li>3. Set digital input function and source instance</li> </ol>
<p>H. Limit Error. Limit status cannot be determined due to a lack of sensor input, limit will trip.</p> <p>L.,E1</p>	<ol style="list-style-type: none"> <li>1. Sensor improperly wired or open</li> <li>2. Incorrect setting of sensor type</li> <li>3. Calibration corrupt</li> </ol>	<ol style="list-style-type: none"> <li>1. Correct wiring or replace sensor</li> <li>2. Match setting to sensor used</li> <li>3. Check calibration of controller</li> </ol>
<p>I. Limit Low. Sensor input below low limit set point.</p> <p>L.,L1</p>	<ol style="list-style-type: none"> <li>1. Temperature is less than limit set point</li> <li>2. Limit outputs latch and require Reset</li> <li>3. Incorrect alarm set point</li> </ol>	<ol style="list-style-type: none"> <li>1. Check cause of under temperature</li> <li>2. Clear limit</li> <li>3. Establish correct limit set point</li> </ol>
<p>J. Limit High. Sensor input above high limit set point.</p> <p>L.,H1</p>	<ol style="list-style-type: none"> <li>1. Temperature is greater than limit set point</li> <li>2. Limit outputs latch and require Reset</li> <li>3. Incorrect alarm set point</li> </ol>	<ol style="list-style-type: none"> <li>1. Check cause of over temperature</li> <li>2. Clear limit</li> <li>3. Establish correct limit set point</li> </ol>

<p>K. Loop Open Error. Open Loop Detect is active and the process value did not deviate by a user-selected value in a user specified period with PID at 100%.</p> <p>LP.01 LP.02</p>	<ol style="list-style-type: none"> <li>1. Setting of Open Loop Detect Time incorrect.</li> <li>2. Setting of Open Loop Detect Deviation incorrect.</li> <li>3. Thermal loop is open.</li> <li>4. Open Loop Detect function not required but activated.</li> </ol>	<ol style="list-style-type: none"> <li>1. Set correct Open Loop Detect Time for application.</li> <li>2. Set correct Open Loop Deviation value for application.</li> <li>3. Determine cause of open thermal loop: misplaced sensors, load failure, loss of power to load, etc.</li> <li>4. Deactivate Open Loop Detect feature.</li> </ol>
<p>L. Loop Reversed Error. Open Loop Detect is active and the process value is headed in the wrong direction when the output is activated based on deviation value and user-selected value.</p> <p>LP.R1 LP.R2</p>	<ol style="list-style-type: none"> <li>1. Setting of Open Loop Detect Time incorrect.</li> <li>2. Setting of Open Loop Detect Deviation incorrect.</li> <li>3. Output programmed for incorrect function.</li> <li>4. Thermocouple sensor wired in reverse polarity.</li> </ol>	<ol style="list-style-type: none"> <li>1. Set correct Open Loop Detect Time for application.</li> <li>2. Set correct Open Loop Deviation value for application.</li> <li>3. Set output function correctly.</li> <li>4. Wire thermocouple correctly (red wire is negative).</li> </ol>
<p>M. Ramping Error. Controller is ramping to new set point.</p> <p>RP 1 RP 2</p>	<ol style="list-style-type: none"> <li>1. Ramping feature is activated.</li> </ol>	<ol style="list-style-type: none"> <li>1. Disable ramping feature if not required.</li> </ol>
<p>N. Autotuning Error. Controller is autotuning the control loop.</p> <p>EUN1 EUN2</p>	<ol style="list-style-type: none"> <li>1. User started the autotune function.</li> <li>2. Digital input is set to start autotune.</li> </ol>	<ol style="list-style-type: none"> <li>1. Wait until autotune completes or disable autotune feature.</li> <li>2. Set digital input to function other than autotune, if desired.</li> </ol>
<p>O. No heat/cool action. Output does not activate load.</p>	<ol style="list-style-type: none"> <li>1. Output function is incorrectly set.</li> <li>2. Control mode is incorrectly set.</li> <li>3. Output is incorrectly wired.</li> <li>4. Load, power or fuse is open.</li> <li>5. Control set point is incorrect.</li> <li>6. Incorrect controller model for application.</li> </ol>	<ol style="list-style-type: none"> <li>1. Set output function correctly.</li> <li>2. Set control mode appropriately (Open vs. Closed Loop).</li> <li>3. Correct output wiring.</li> <li>4. Correct fault in system.</li> <li>5. Set control set point in appropriate control mode and check source of set point: remote, idle, profile, closed loop, open loop.</li> <li>6. Obtain correct controller model for application.</li> </ol>
<p>P. No display indication or LED illumination.</p>	<ol style="list-style-type: none"> <li>1. Power to controller is off</li> <li>2. Fuse open</li> <li>3. Breaker tripped</li> <li>4. Safety interlock switch open</li> <li>5. Separate system limit control activated</li> <li>6. Wiring error</li> <li>7. Incorrect voltage to controller</li> </ol>	<ol style="list-style-type: none"> <li>1. Turn on power</li> <li>2. Replace fuse</li> <li>3. Reset breaker</li> <li>4. Close interlock switch</li> <li>5. Reset limit</li> <li>6. Correct wiring issue</li> <li>7. Apply correct voltage, check part number</li> </ol>
<p>Q. No serial communication. Cannot establish serial communications with the controller.</p>	<ol style="list-style-type: none"> <li>1. Address parameter incorrect</li> <li>2. Incorrect protocol selected</li> <li>3. Baud rate incorrect</li> <li>4. Parity incorrect</li> <li>5. Wiring error</li> <li>6. EIA-485 converter issue</li> <li>7. Incorrect computer or PLC communications port</li> <li>8. Incorrect software setup</li> <li>9. Termination resistor may be required</li> </ol>	<ol style="list-style-type: none"> <li>1. Set unique addresses on network</li> <li>2. Match protocol between devices</li> <li>3. Match baud rate between devices</li> <li>4. Match parity between devices</li> <li>5. Correct wiring issue</li> <li>6. Check settings or replace converter</li> <li>7. Set correct communication port</li> <li>8. Correct software setup to match controller</li> <li>9. Place 120 Ω resistor across EIA-485 on last controller</li> </ol>

<p>R. Process does not control to set point. Process is unstable or never reaches set point.</p>	<ol style="list-style-type: none"> <li>1. Controller not tuned correctly.</li> <li>2. Control mode is incorrectly set.</li> <li>3. Control set point is incorrect.</li> </ol>	<ol style="list-style-type: none"> <li>1. Perform autotune or manually tune system.</li> <li>2. Set control mode appropriately (Open vs. Closed Loop).</li> <li>3. Set control set point in appropriate control mode and check source of set point: remote, idle, profile, closed loop, open loop.</li> </ol>
<p>S. Temperature runaway. Process value continues to increase or decrease past set point.</p>	<ol style="list-style-type: none"> <li>1. Controller output incorrectly programmed</li> <li>2. Thermocouple reverse wired</li> <li>3. Controller output wired incorrectly</li> <li>4. Short in heater</li> <li>5. Power controller connection to controller defective</li> <li>6. Controller output defective</li> </ol>	<ol style="list-style-type: none"> <li>1. Verify output function is correct (heat or cool)</li> <li>2. Correct sensor wiring (red wire negative)</li> <li>3. Verify and correct wiring</li> <li>4. Replace heater</li> <li>5. Replace or repair power controller</li> <li>6. Replace or repair controller</li> </ol>
<p>T. Device Error. Controller displays internal malfunction message at power up.</p> <p><b>100</b> <b>RETN</b></p>	<ol style="list-style-type: none"> <li>1. Controller defective</li> <li>2. Miss wired input or ground loop</li> </ol>	<ol style="list-style-type: none"> <li>1. Replace or repair controller</li> <li>2. Correct wiring or remove ground loop circuit</li> </ol>
<p>U. Heater Error.</p> <p><b>H. ER</b></p>	<ol style="list-style-type: none"> <li>1. Current through load is above current trip set point.</li> <li>2. Current through load is below current trip set point.</li> </ol>	<ol style="list-style-type: none"> <li>1. Check that the load current is proper. Correct cause of overcurrent and/or ensure current trip set point is correct.</li> <li>2. Check that the load current is proper. Correct cause of undercurrent and/or ensure current trip point is correct.</li> </ol>
<p>V. Current Error. Load current incorrect.</p> <p><b>C. ER</b></p>	<ol style="list-style-type: none"> <li>1. Short solid-state or mechanical relay.</li> <li>2. Open solid-state or mechanical relay.</li> <li>3. Current transformer load wire associated to wrong output.</li> <li>4. Defective current transformer or controller.</li> <li>5. Noisy electrical lines.</li> </ol>	<ol style="list-style-type: none"> <li>1. Replace relay.</li> <li>2. Replace relay.</li> <li>3. Route load wire through current transformer from correct output, and go to the Source Output Instance parameter (Setup Page, Current Menu) to select the output that is driving the load.</li> <li>4. Replace or repair sensor or controller.</li> <li>5. Route wires appropriately, check for loose connections, add line filters.</li> </ol>
<p>W. Menus inaccessible. Unable to access:</p> <p><b>SET</b> <b>OPER</b> <b>FCTY</b> <b>PROF</b></p> <p>menus or particular prompts in Home Page.</p>	<ol style="list-style-type: none"> <li>1. Lockout or Security set to incorrect level</li> <li>2. Digital input set to lockout keypad</li> <li>3. Custom parameters incorrect</li> </ol>	<ol style="list-style-type: none"> <li>1. Check lockout setting in Factory Page</li> <li>2. Change state of digital input</li> <li>3. Change custom parameters in Factory Page</li> </ol>
<p>X. EZ-Keys do not activate required function.</p>	<ol style="list-style-type: none"> <li>1. EZ-Key function incorrect</li> <li>2. EZ-Key function instance not correct</li> <li>3. Keypad malfunction</li> </ol>	<ol style="list-style-type: none"> <li>1. Verify EZ-Key function in Setup Menu</li> <li>2. Check that the function instance is correct</li> <li>3. Replace or repair controller</li> </ol>
<p>Y. Value too low to be displayed in 4 digit LED display.</p> <p><b>VAL.L</b></p>	<ol style="list-style-type: none"> <li>1. Incorrect setup</li> </ol>	<ol style="list-style-type: none"> <li>1. Check scaling of source data</li> </ol>
<p>Z. Value too high to be displayed in 4 digit LED display.</p> <p><b>VAL.H</b></p>	<ol style="list-style-type: none"> <li>1. Incorrect setup</li> </ol>	<ol style="list-style-type: none"> <li>1. Check scaling of source data</li> </ol>

## 9 SERVICING

 <b>Attention</b>	<p>Before proceeding, follow the Pressure Relief Procedure outlined previously in this manual. Additionally, follow all other warnings to reduce the risk of an injection injury, injury from moving parts or electric shock. Always unplug the sprayer before servicing!</p>
	<p>All service instructions apply to both Component A and Component B pumps, unless otherwise specified. If ordering a new motor controller (Fig. 17, item 12), make sure to order it for the correct Component Pump (see "Drive Assembly" in the Spare Parts List section, page 88-89).</p>

### 9.1 REPLACING THE MOTOR ASSEMBLY (FIG. 17)

1. Disconnect the power cord.
2. Loosen and remove the two motor shroud screws (1). Remove the motor shroud (2).
3. Loosen and remove the three belly pan screws (3). Remove the belly pan (4).
4. Loosen and remove the two motor cover screws (5). Remove the motor cover (6).
5. Disconnect all wires between the motor and the sprayer.
6. Disconnect the wires between the motor (9) and the control panel.
7. Loosen and remove the two motor controller screws (11). Remove the motor controller (12).
8. Loosen and remove the four motor baffle screws (13). Remove the motor baffle (14).
9. Loosen and remove the three motor mounting screws (15).
10. Pull the motor out (9) of the gearbox housing (16).
11. With the motor removed, inspect the gears in the gearbox housing for damage or excessive wear. Replace the gears, if necessary.
12. Install the new motor (9) into the gearbox housing.
13. Secure the motor with the three motor mounting (15) screws.
14. Reconnect the wires between the sprayer and the new motor (refer to the **Electrical Schematic**, section 9.7).
15. Place the baffle (14) over the end of the motor assembly (9). Secure with the four motor baffle screws (13).
16. Place motor controller (12) back into place behind the motor baffle (14). Secure with the two motor controller screws (11).
17. Reconnect all wires between the motor and sprayer.
18. Reconnect the wires between the motor and the control panel.
19. Place the motor cover back over the motor controller. Secure with the two (5) motor cover screws.
20. Put the belly pan (4) back in place and secure with the three belly pan screws (3).
21. Slide the motor shroud (2) over the motor assembly (9).
22. Secure the motor shroud (2) with the two motor shroud screws (1).

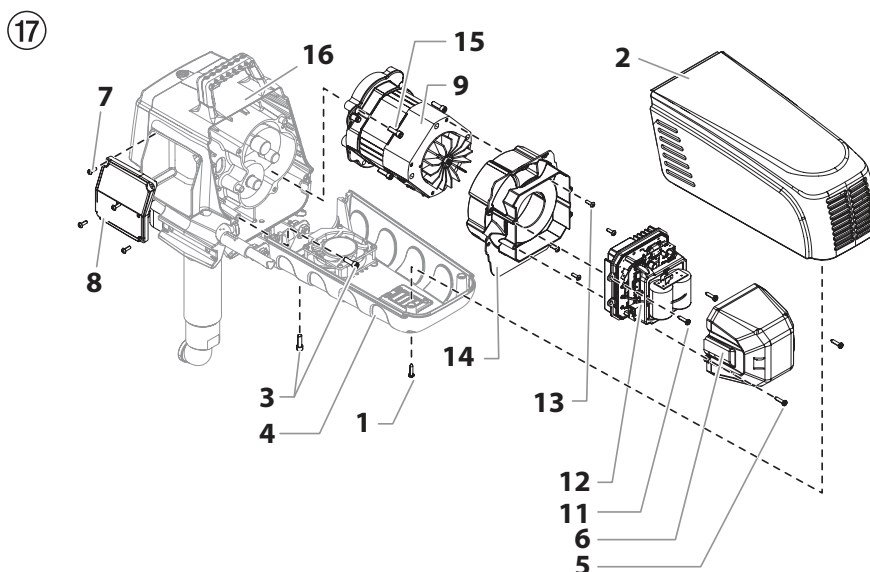

**9.2 REPLACING THE GEARS (FIG. 18)**

1. Follow steps 1-10 in **Replacing the Motor Assembly** to remove the motor and control panel.
2. Inspect the armature gear (1) on the end of the motor for damage or excessive wear. If the gear is completely worn out, replace the motor assembly.
3. Remove and inspect the 1st stage gear (2) and 2nd stage gear (3) assemblies for damage or excessive wear. Replace, if necessary.
4. Inspect the front gear box assembly (4) for damage or excessive wear. If damaged or worn, replace the front gear box assembly.



Clean and refill the gear box cavity up to the rear face of each gear with Lubriplate (P/N 314-171).

5. Reinstall the motor into the gearbox housing.
6. Follow steps 11-22 in **Replacing the Motor Assembly** to replace the motor and control panel.

18

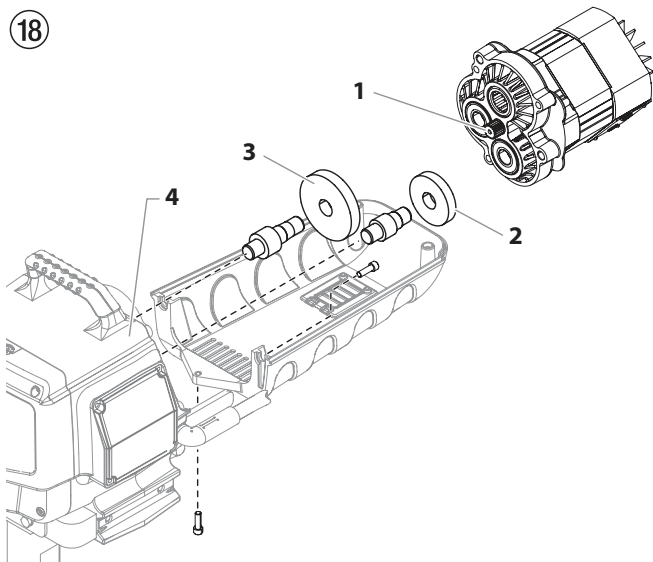

**9.3 REPLACING THE TRANSDUCERS (FIG. 19/20)**

1. Disconnect the power cord.
2. Loosen the hex nut (fig. 19, item 1) in between the PRIME/SPRAY manifold and the heater block. Loosen it just enough so that it can be moved by hand.

19

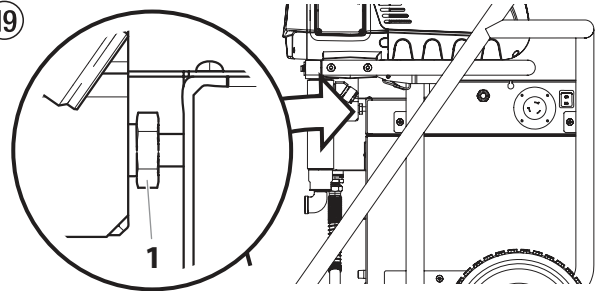

Component Pump (B) has been removed from the graphic below for instructional purposes only. You will not have to remove the component pump to complete these steps.

3. Loosen and remove the two screws (fig. 20, item 2) that secure the front top cover (3) to the heater block and the four screws (4) that secure the rear top cover (5) to the heater block. Remove both covers from the heater block.
4. Disconnect the hose from the fluid section (6). Disconnect the hose from the valve at the front of the heater block (7). Leave the hoses attached to the PRIME/SPRAY manifold (8).

20

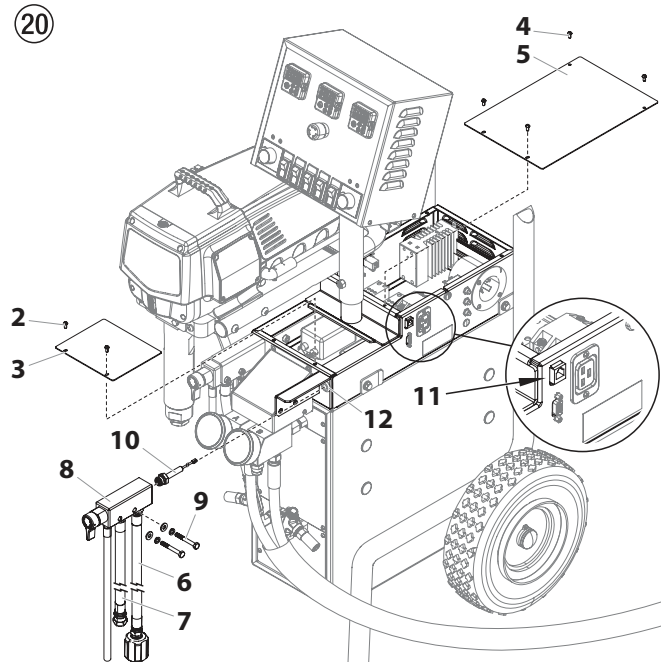

5. Loosen and remove the two PRIME/SPRAY knob manifold screws (9). Be careful not to lose the flat or lock washers.
6. Pull the PRIME/SPRAY manifold (8), with transducer assembly (10) still attached forward. The transducer connection should be visible inside the heater block at the rear (11).
7. Disconnect the transducer cord from rear of the connector inside the heater block (11).
8. Fully unthread the transducer assembly (10) from the PRIME/SPRAY manifold (8).
9. Thread the new transducer assembly (10) into the PRIME/SPRAY manifold (8). Run the transducer wire through the grommit (12) in the front of the heater block and reconnect to its connection at the rear of the heater block (11).
10. Replace the PRIME/SPRAY manifold (8). Secure with the two PRIME/SPRAY manifold screws (9).
11. Reconnect the hoses at the block heater valves (6) and the fluid section (7).
12. Replace the front top cover (3) and the rear top cover (4). Secure with the screws.

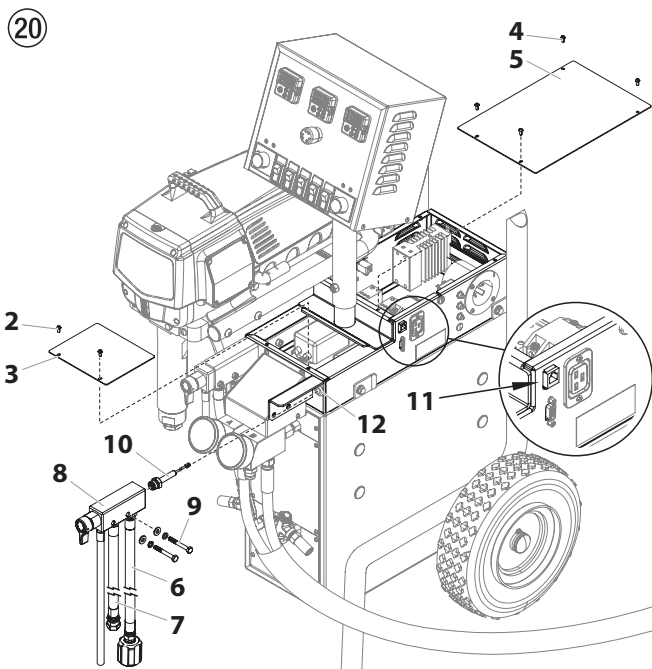

## 9.4 REPLACING THE PRIME/SPRAY VALVE



Perform the following procedure using PRIME/SPRAY valve replacement kit P/N 800-915.

1. Use a drift punch of 2 mm to remove the grooved pin (Fig. 22, item 1) from the relief valve handle (2).
2. Remove the relief valve handle (2) and cam base (3).
3. Using a wrench, remove the valve housing (4).
4. Ensure that the seal (5) is seated correctly, then screw the new valve housing (4) completely into the block (6). Tighten securely with a wrench.
5. Align the cam base (3) with the hole in the block (6). Lubricate the cam base with grease and slide on the cam base.
6. Bring the hole in the valve shaft (7) and in the relief valve handle (2) into alignment.
7. Insert the grooved pin (1) to secure the relief valve handle in position.

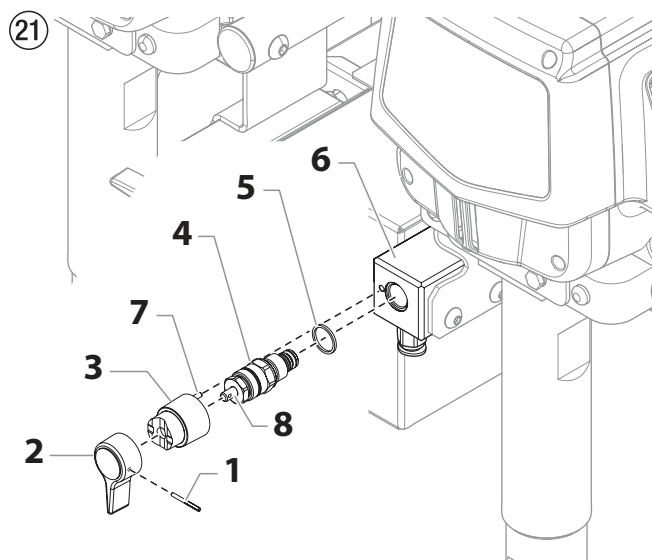



9.5 INLET AND OUTLET VALVE



Before proceeding, follow the Pressure Relief Procedure outlined previously in this manual. Additionally, follow all other warnings to reduce the risk of an injection injury, injury from moving parts or electric shock. Always unplug the sprayer before servicing!

1. Remove the four screws in the front cover and then remove the front cover.



Danger of crushing - do not reach with the fingers or tool between the moving parts.

2. Turn the pressure control knob to minimum pressure.
3. Press the #4 key on the Control Display control panel. The Cycles Per Minute (CPM) screen will appear. Now press the #1 key on the control panel. The Creep Mode screen will now appear.
4. Slowly turn the pressure control knob clockwise to increase the pressure. The crankshaft/slider assembly will begin to move very slowly.
5. When it reaches the bottom, dead-center of its stroke, turn the pressure control knob back to minimum pressure. The crankshaft/slider assembly should stop.
6. Unplug the power plug from the outlet.
7. Unscrew the connection hose from the nipple on the back of the fluid section cylinder.
8. Loosen and remove the inlet valve housing (1) from the cylinder (2).
9. Remove bearing ring (9), O-ring (8), O-ring (7), inlet valve seat (6), inlet valve ball (5) upper ball guide (4) and spring (3).
10. Clean all the parts with the corresponding cleaning agent. Check the inlet valve housing (1), inlet valve seat (6) and inlet valve ball (5) for wear and replace the parts if necessary. If the worn inlet valve seat (6) is unused on one side, install it the other way around.

22

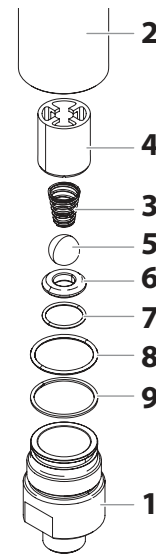

11. Screw out outlet valve housing (Fig. 23, item 10) from the piston (11) with 3/8 inch hexagon socket head wrench.
12. Remove the upper seal (16), upper ball guide (15), outlet valve ball (13), washer (14) and outlet valve seating (12).
13. Clean all the parts with the corresponding cleaning agent. Check outlet valve housing (10), outlet valve seat (12), outlet valve ball (13) and upper ball guide (15) for wear and replace parts if necessary. If the worn outlet valve seat (12) is unused on one side, install it the other way around.
14. Carry out installation in the reverse order.
15. If you plan to replace the fluid section packings, move on to section 9.6. If not, reassemble fluid section in the reverse order of how it was disassembled.

23

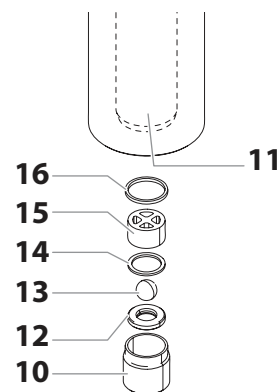

## 9.6 PACKINGS

1. Remove inlet valve housing in accordance with the steps in Section 9.5.
2. It is not necessary to remove the outlet valve.
3. Pull the lever on the underside of the sprayer toward the front of the sprayer. This will un-clip the entire fluid section.
4. Slide the fluid section forward to remove it from the gear housing.
5. Place the fluid section cylinder upright in a vise by clamping on the wrench flats (Fig. 24, Item 2).



Do not over-tighten the vise. Damage to the cylinder may occur.

6. Using a wrench, remove the upper seal retainer (Fig. 24, Item 3).
7. Slide the piston rod (4) out through the bottom of the cylinder (1).
8. Inspect the piston rod for wear and replace if necessary.
9. Remove the upper support ring (8) and upper packing assembly (5) from the top of the cylinder (1).
10. Remove the adapter (6) and lower packing assembly (7) from the bottom of the cylinder.



Be careful not to scratch, score, or otherwise damage the cylinder during removal of the packings.

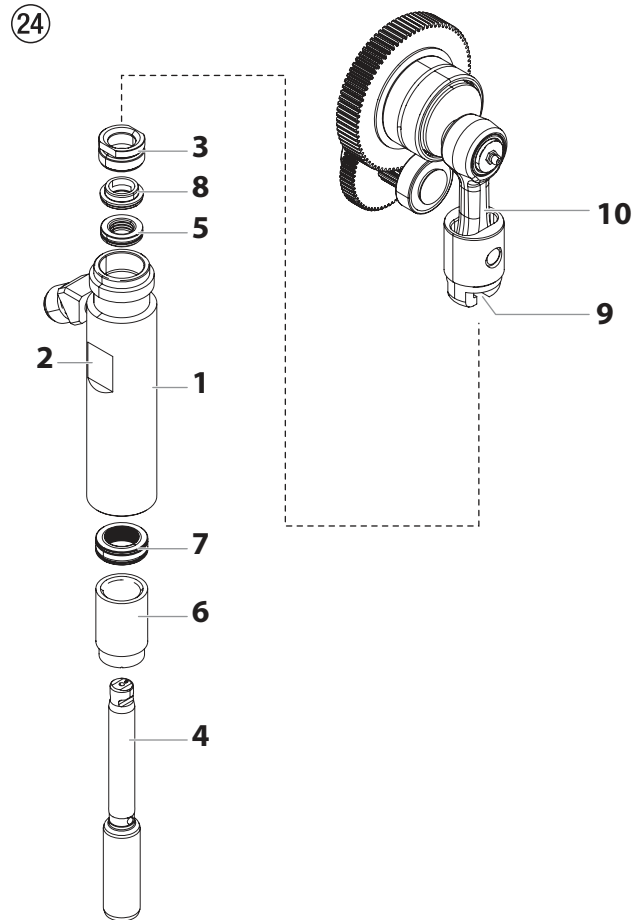

11. Clean the cylinder (1). Inspect the cylinder for damage and replace if necessary.
12. Place the cylinder upright (1) in a vise by clamping on the wrench flats (2).
13. Locate the new upper and lower packings and remove the pre-form tools. Save the upper packing pre-form tool for use as the piston insertion tool later in this procedure.



Do not remove the pre-form tools from the upper and lower packings until immediately before they are installed into the cylinder.

14. Lubricate upper packing (5) and lower packing (7) with machine grease.
15. Insert upper packing (Fig. 25) with O-ring and protruding lip (11) downward.

25



16. Insert upper support ring (8) on top of the upper packing (5)
17. Thread the upper seal retainer (3) into the cylinder (1).
18. Rotate the cylinder in the vise so that the bottom end is facing up.
19. Insert the lower packing (Fig. 26) partially into the bottom of the cylinder with the large beveled edge (12) facing toward the cylinder (beveled edge will be facing up when the cylinder is upright).

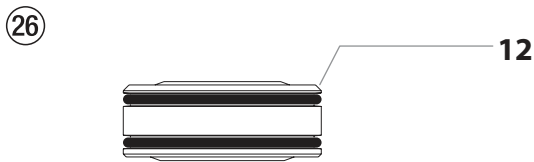

20. Push the lower packing assembly (Fig. 24, Item 7) into position using the lower packing insertion tool (see Fluid Section Assembly parts list for lower packing insertion tool P/N).

<b>i</b>	Coat the piston insertion tool (i.e. upper packing pre-form tool) and the piston rod with grease before inserting them into the cylinder.
----------	---

21. Place the piston insertion tool over the top of the piston rod (4).
22. Insert the piston rod (4) into the bottom of the cylinder (1), through the lower packing assembly (7), through the upper packing assembly (5), and out through the upper seal retainer (3).

<b>i</b>	Make sure the raised lip on the bottom of the lower packing is fully outside the packing around the piston rod after insertion of the piston rod.
----------	---

23. Remove the piston insertion tool from the top of the piston rod (4).
24. Replace the cylinder (1) back into the fluid section clamp on the gear housing. Make sure to slide the top of the piston rod extension into the T-slot (9) on the slider assembly (10).
25. Push the lever on the underside of the unit toward the rear of the sprayer to lock the fluid section back into place.
26. Insert the adapter (6) into the bottom of the cylinder (1).

27. Making sure that the bearing ring (Fig. 22, item 9) and O-rings (Fig. 22, items 7-8) are lubricated and in place, reassemble the inlet valve assembly and thread it into the cylinder. Tighten the inlet valve housing until the o-ring engages, then continue to tighten until snug. Once snug, tighten an additional 1/8–1/4 turn.
28. Attach the high-pressure hose to the nipple on the back of the cylinder and tighten by hand. Do not kink the hose.

<b>i</b>	Make sure the hose does not touch the cart frame. If it does, reposition the nipple by turning the cylinder until the hose is clear of the frame and the nipple is within 45° of the back of the unit.
----------	--

29. Install front cover.

**9.7 ELECTRICAL SCHEMATIC (MODEL 0138010 / 2407046)**

Wiring		Notes (refer to next page)	
1	Black	a	This end mounted to enclosure
2	Red	b	To contact (0522532)
3	White	c	To surge protector
4	Green	d	To relay (0522536)
5	Blue	e	To 2A breaker (0522068)
6	Brown	f	To hose heater
		g	From 0138501 (thermocouple) located in 0138270 (manifold)
		h	Ground stud on display
		i	To ground stud on enclosure

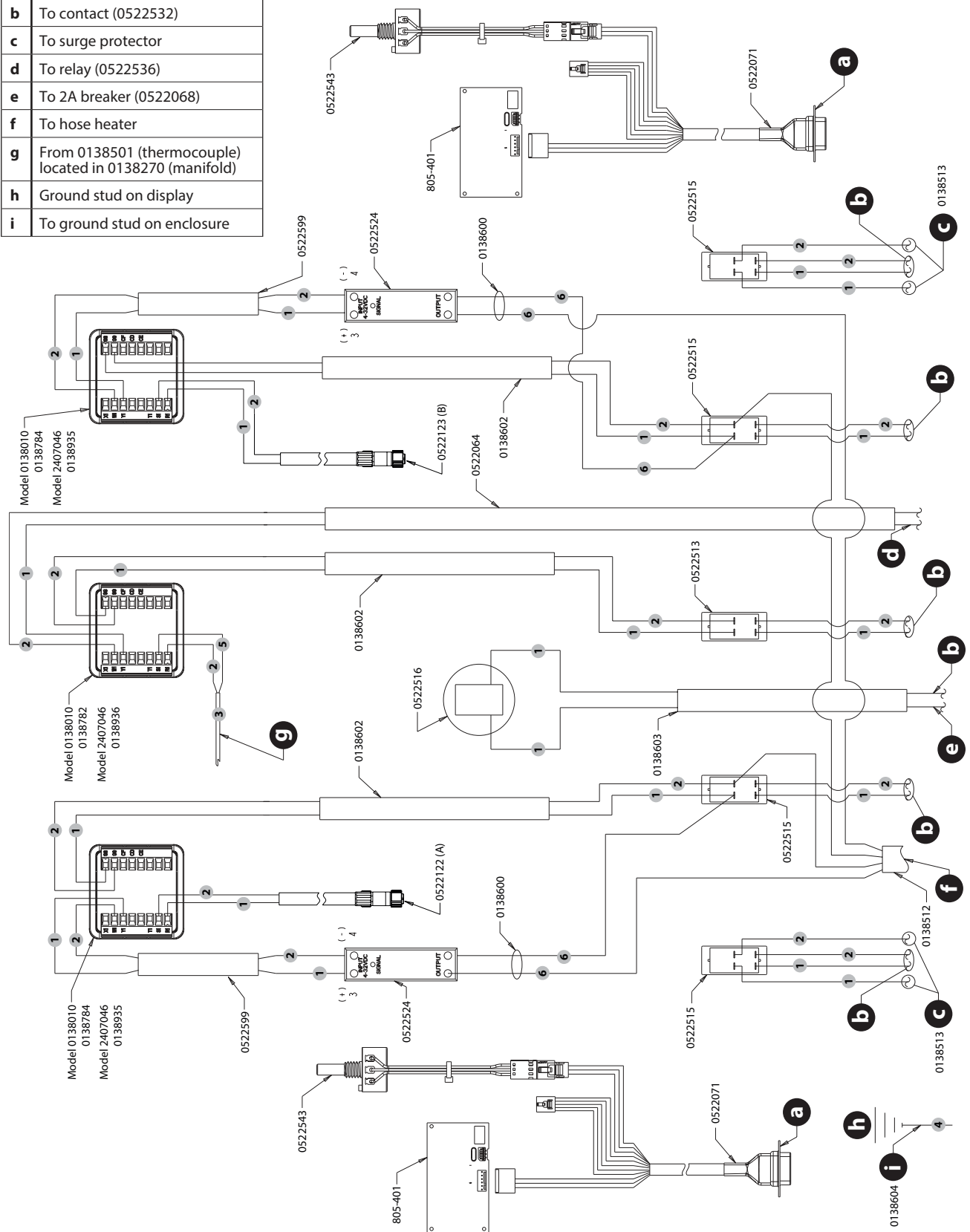

Notes (refer to previous page)	
<b>a</b>	This end mounted to enclosure
<b>b</b>	From switches
<b>c</b>	From "c", previous page
<b>d</b>	From "d", previous page
<b>e</b>	From Emergency Stop (0522516)
<b>f</b>	From "f", previous page
<b>g</b>	To controller (0138542)
<b>h</b>	From "h", previous page
<b>i</b>	Ground stud on enclosure

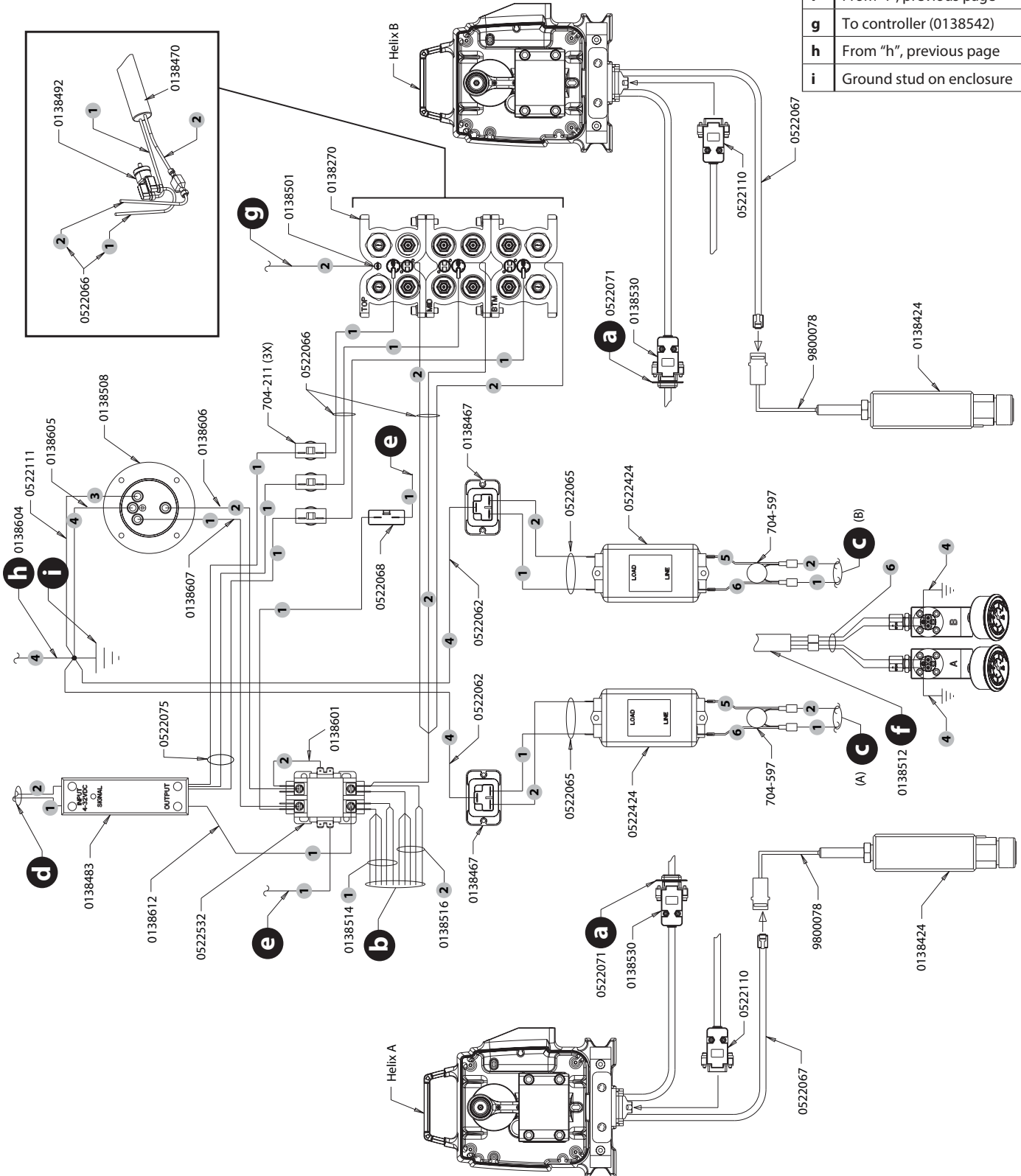

**9.8 ELECTRICAL SCHEMATIC (MODEL 0138057 / 2405634)**

Wiring		Notes (refer to next page)	
1	Black	a	This end mounted to enclosure
2	Red	b	To contact (0522532)
3	White	c	To surge protector
4	Green	d	To relay (0522536)
5	Blue	e	To 2A breaker (0522068)
6	Brown	f	To hose heater
		g	From 0138501 (thermocouple) located in 0138270 (manifold)
		h	Ground stud on display
		i	To ground stud on enclosure

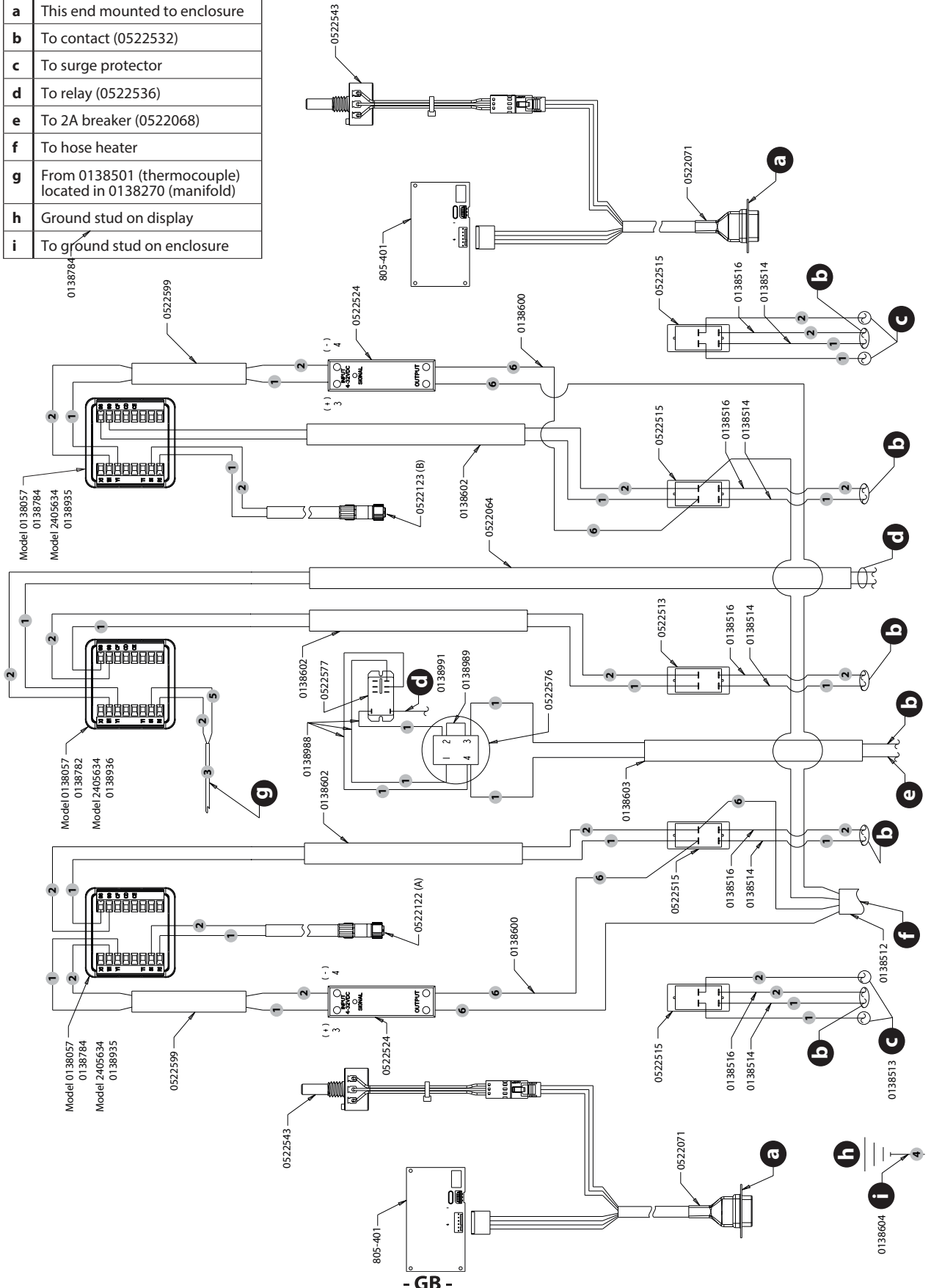

Notes (refer to previous page)	
<b>a</b>	This end mounted to enclosure
<b>b</b>	From switches
<b>c</b>	From "c", previous page
<b>d</b>	From "d", previous page
<b>e</b>	From Emergency Stop (0522516)
<b>f</b>	From "f", previous page
<b>g</b>	To controller (0138542)
<b>h</b>	From "h", previous page
<b>i</b>	Ground stud on enclosure
<b>j</b>	To "Y1" on 0138936 controller
<b>k</b>	To "W1" on 0138936 controller
<b>l</b>	From relay coil above

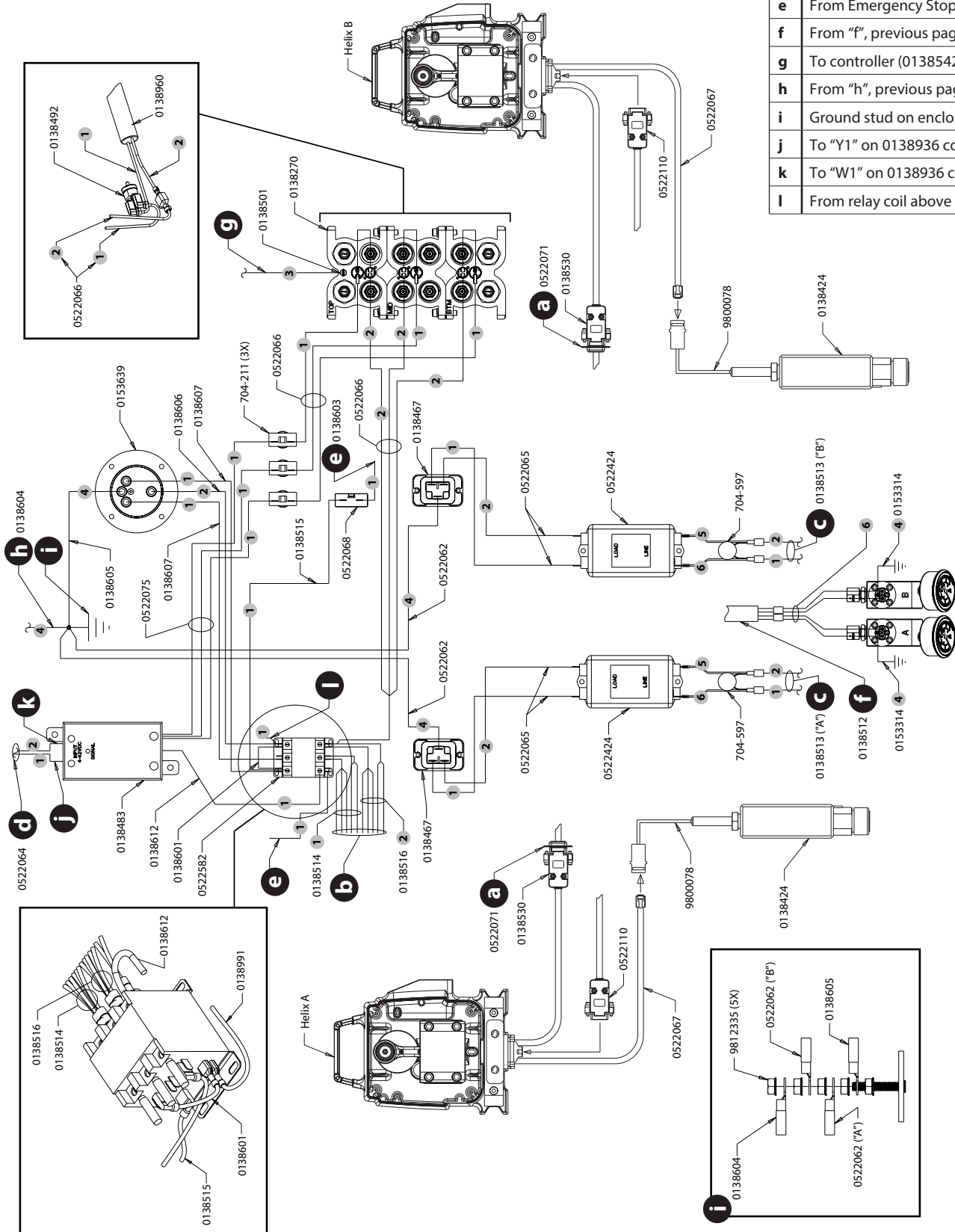

MAIN ASSEMBLY

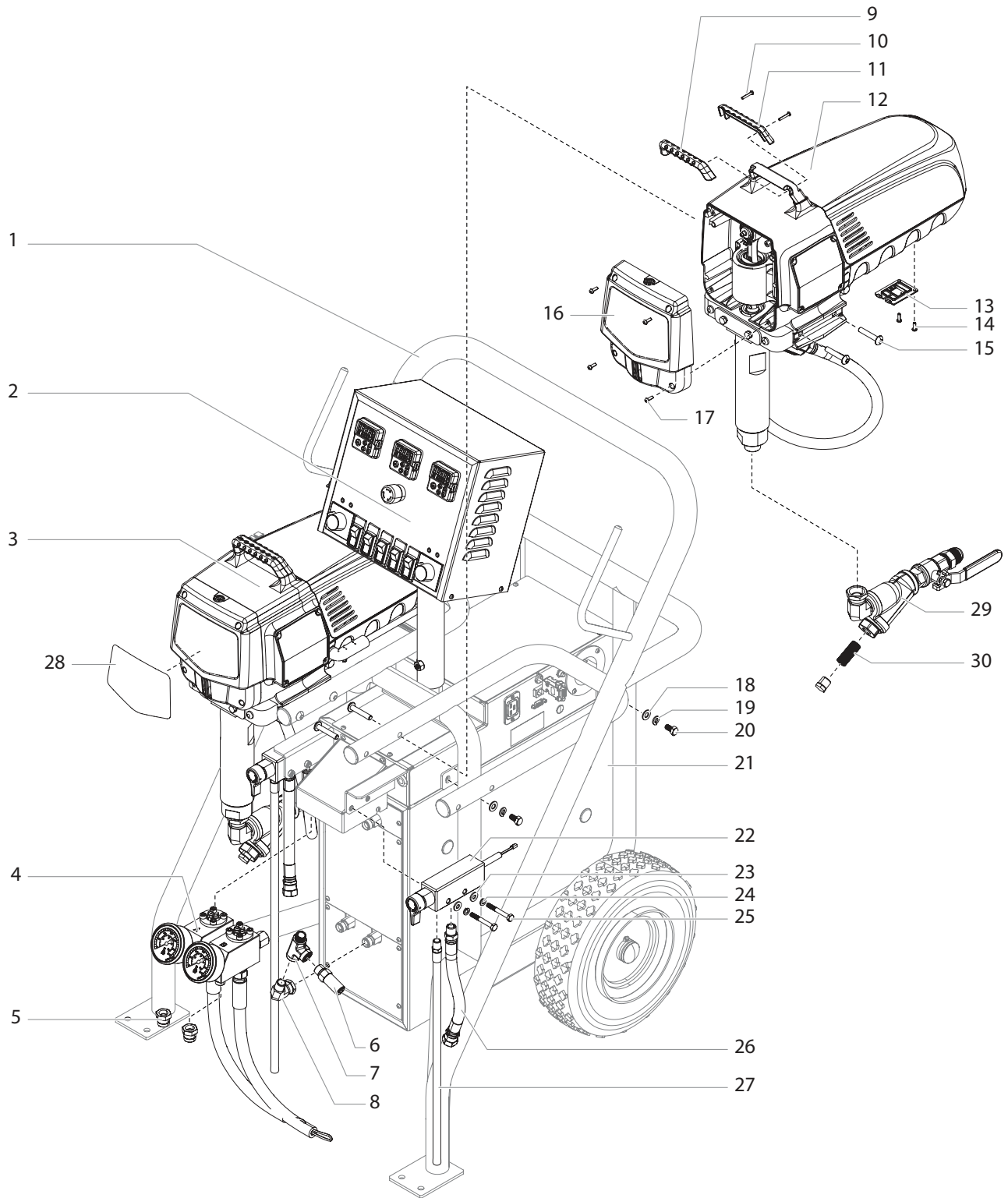



Pos.	Helix A / B	Description
1*	-----	Cart assembly
2*	-----	Control panel assembly
3*	-----	Pump assembly, A side
4*	0521237	Surefire™ heated hose assembly, 200'
	0138296	Surefire™ heated hose assembly, 100'
5	0138597	Plug (2)
6	0138489	Relief valve (2)
7	424-671	Tee fitting (2)
8	0090447	Elbow (2)
9	805-333	Front cover handle (2)
10	9805317	Screw (2)
11	805-332	Rear cover handle (2)
12*	-----	Pump assembly, B side
13	0138474	Port cover (2)
14	700-139	Screw (4)
15	9805348	Screw (8)
16	805-250A	Face plate / oiler assembly (2)

Pos.	Helix A / B	Description
17	700-139	Screw (8)
18	756-088	Washer (4)
19	860-002	Lock washer (4)
20	9805438	Screw (4)
21*	-----	Surefire™ heater block assembly
22*	-----	PRIME/SPRAY valve assembly (2)
23	770-601	Washer (4)
24	9821503	Lock washer (4)
25	9805437	Screw (4)
26	0138666	Hose, A side
	0138473	Hose, B side
27	800-904	Bleed hose (2)
28	0138852	Label, A side
	0138853	Label, B side
29	0138285	Y strainer valve assembly (2)
30	0138038	Y strainer screen (2)

\* See separate listing



When ordering any part number, you will receive a quantity of 1 of that part. If multiples of any part need to be ordered, please specify when ordering.

COMPONENT PUMP ASSEMBLY

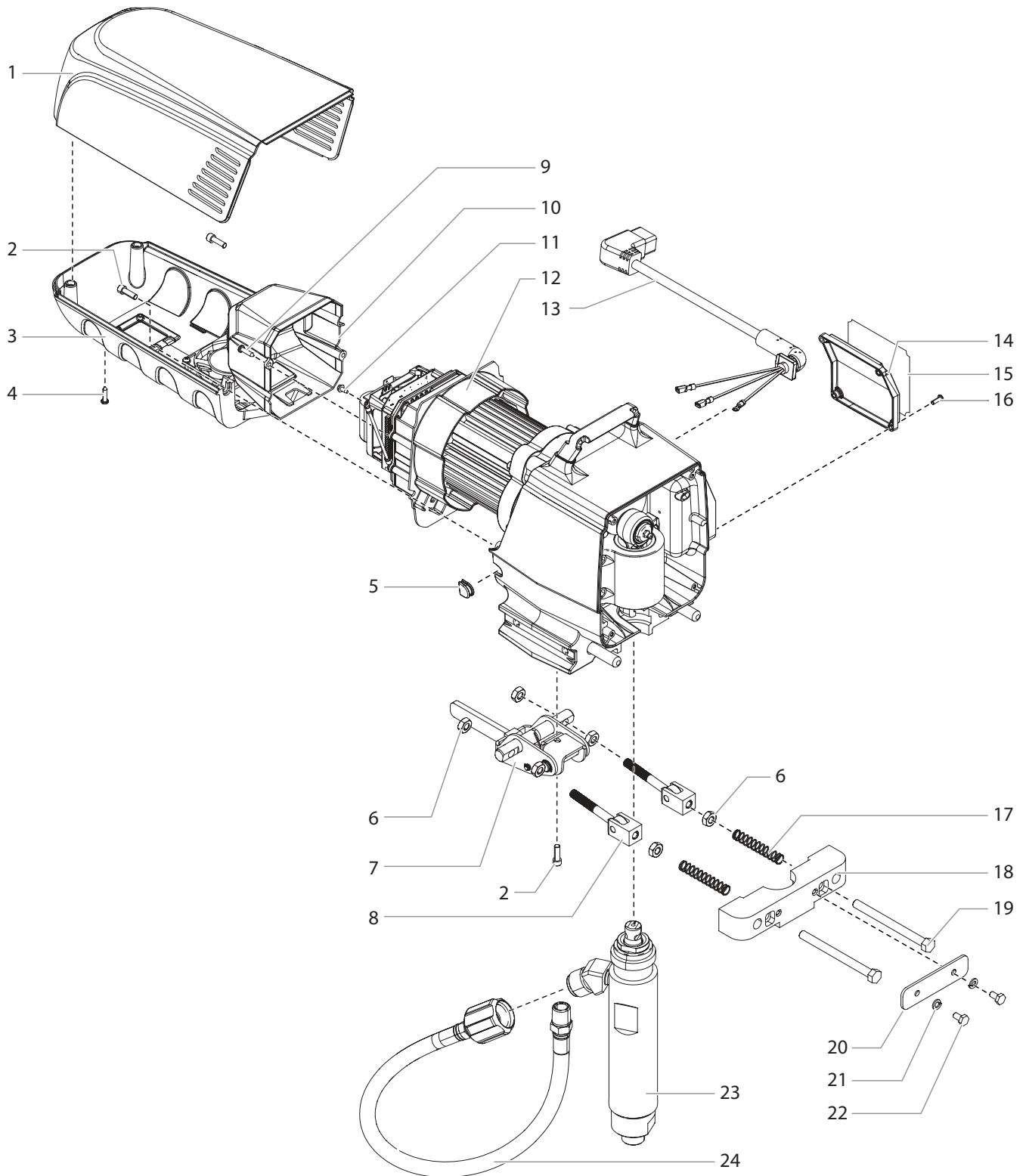

Pos.	Helix A	Helix B	Description
1	805-425	805-425	Motor shroud
2	700-681	700-681	Screw (3)
3	0138284A	0138284A	Belly pan assembly
4	9802266	9802266	Screw (2)
5	0138519	0138518	Plug
6	9812320	9812320	Nut (6)
7	805-286A	805-286A	Lever assembly
8	805-287A	805-287A	Clevis assembly (2)
9	9802266	9802266	Screw (2)
10	805-462	805-462	Electronic cover
11	9800340	9800340	Ground screw (2)
12*	-----	-----	Drive assembly
13	0138466	0138465	Power cord assembly
14	0552554A	0552554A	Panel
15	0138872	0138872	Label
16	700-139	700-139	Screw (4)
17	9894274	9894274	Spring (2)
18	805-464	805-464	Retainer
19	9805362	9805362	Bolt (2)
20	0558795	0558795	Plate
21	9821503	9821503	Lock washer (2)
22	858-625	858-625	Screw
23*	0138039A	0138277A	Fluid section assembly
24	0138667	805-297	Hose

\* See separate listing



This parts list applies for both Pump A and Pump B. Items 5 and 13 are installed in different locations, depending upon the pump.

DRIVE ASSEMBLY

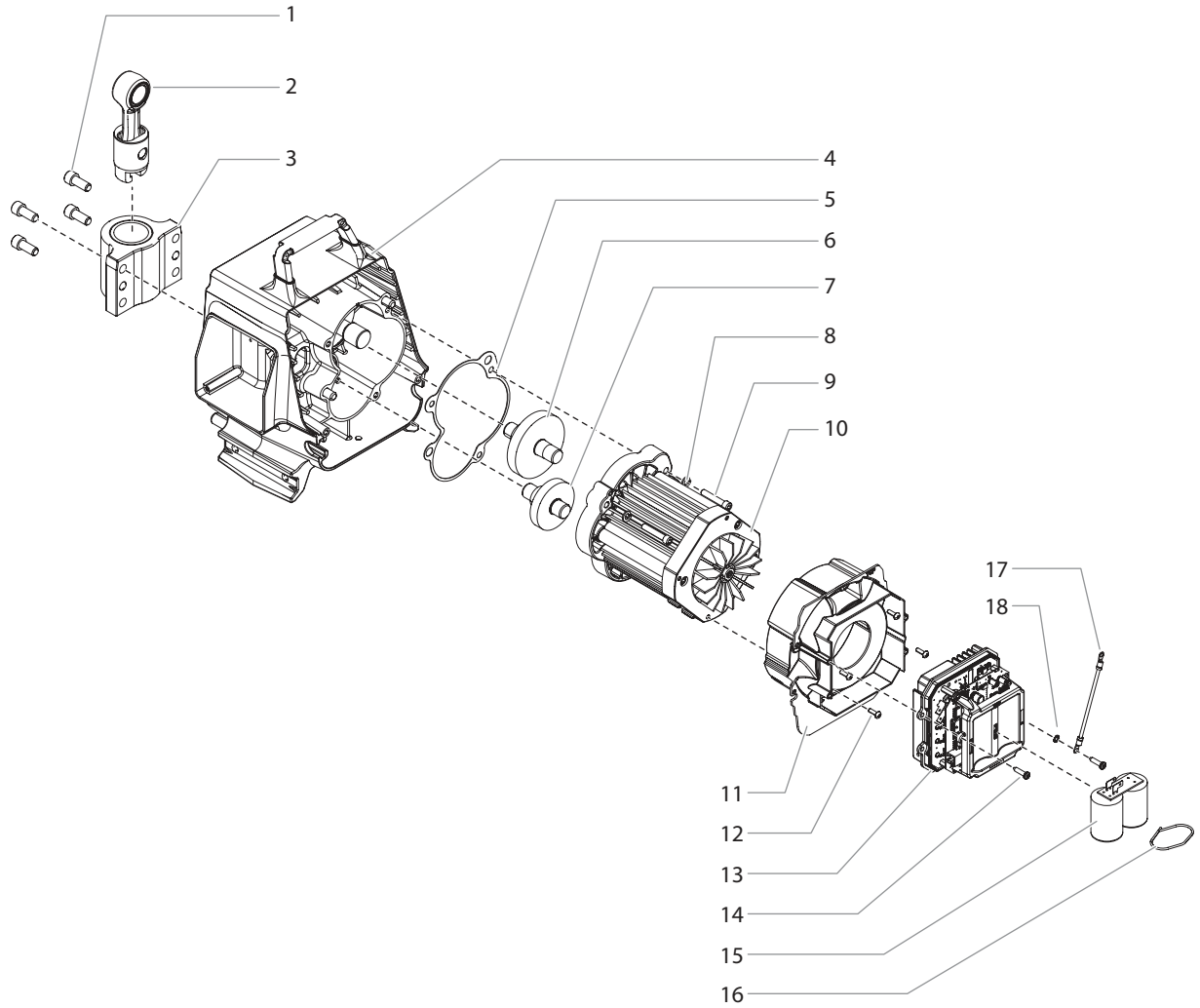

---

<b>Pos.</b>	<b>Helix A</b>	<b>Helix B</b>	<b>Description</b>
<b>1</b>	700-283	700-283	Screw (4)
<b>2</b>	0558572A	0558572A	Slider assembly
<b>3</b>	805-248A	805-248A	Slider housing
<b>4</b>	805-244A	0138274A	Housing assembly
<b>5</b>	800-525	800-525	Gasket
<b>6</b>	0558362A	0558362A	3rd stage gear
<b>7</b>	0558363A	0558363A	2nd stage gear
<b>8</b>	9821503	9821503	Lock washer (3)
<b>9</b>	700-287	700-287	Screw (3)
<b>10</b>	0558737A	0558737A	Motor assembly
<b>11</b>	805-460	805-460	Motor baffle
<b>12</b>	700-139	700-139	Screw (4)
<b>13</b>	0138634	0138635	Electronic control assembly
<b>14</b>	9802266	9802266	Screw (2)
<b>15</b>	0522051	0522051	Capacitor assembly
<b>16</b>	770-099	770-099	Tie wrap
<b>17</b>	0522040	0522040	Wire assembly
<b>18</b>	9822106	9822106	Washer

HEATER BLOCK ASSEMBLY

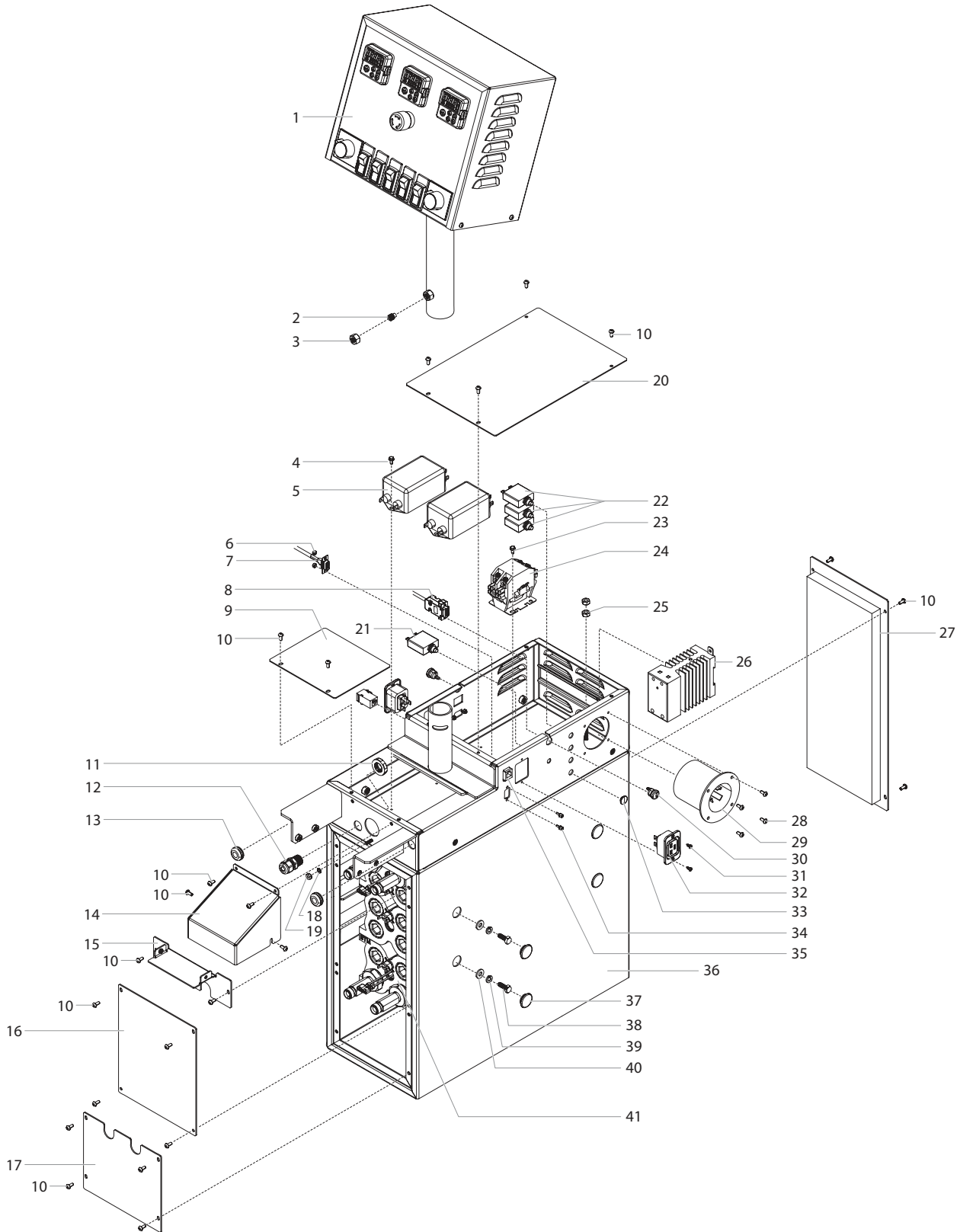

Pos.	Helix A / B 0138010 0138061	Helix A / B 0138057 0138062	Description
1*	-----	-----	Display assembly
2	9805436	9805436	Set screw
3	862-401	862-401	Jam nut
4	9800340	9800340	Screw (4)
5	0522424	0522424	EMI filter, 20A (2)
6	0293489	0293489	Nut (4)
7	0522071	0522071	Wire assembly (2)
8	0522110	0522110	Communication cable
9	0138493	0138493	Top enclosure, front
10	730-260	730-260	Screw (24)
11	765-087	765-087	Nut
12	765-063	765-063	Strain relief
13	0138471	0138471	Grommit (2)
14	0138452	0138452	Hose heater cover
15	0138482	0138482	Enclosure door assembly, front
16	0138451	0138451	Enclosure door, front, middle
17	0138494	0138494	Enclosure door, front, bottom
18	9822106	9822106	Washer
19	0524353	0524353	Nut
20	0138453	0138453	Top enclosure, rear
21	0522068	0522068	Circuit breaker, 2 A

Pos.	Helix A / B 0138010 0138061	Helix A / B 0138057 0138062	Description
22	704-211A	704-211A	Circuit breaker, 12 A (3)
23	9800340	9800340	Screw (4)
24	0522532	0522582	Contact, 40A
25	9812335	9812335	Nut (3)
26	0138483	0138483	Relay
27	0138446A	0138446A	Rear enclosure with insulation
28	9805287	9805287	Screw (4)
29	0138508	0153639	Receptacle, 50A
30	0138509	0138509	Strain relief (2)
31	9805440	9805440	Screw (4)
32	0138467	0138467	Receptacle, 15A
33	9800084	9800084	Plug
34	9800086	9800086	Screw lock (4)
35	9800078	9800078	Coupler (2)
36	0138449A	0138449A	Enclosure weldment with insulation
37	0138485	0138485	Plug (8)
38	9805439	9805439	Screw (8)
39	9821503	9821503	Lock washer (4)
40	770-601	770-601	Washer (4)
41*	0138270A	0138270A	Heater block assembly, 3 stack

\* See separate listing

DISPLAY ASSEMBLY

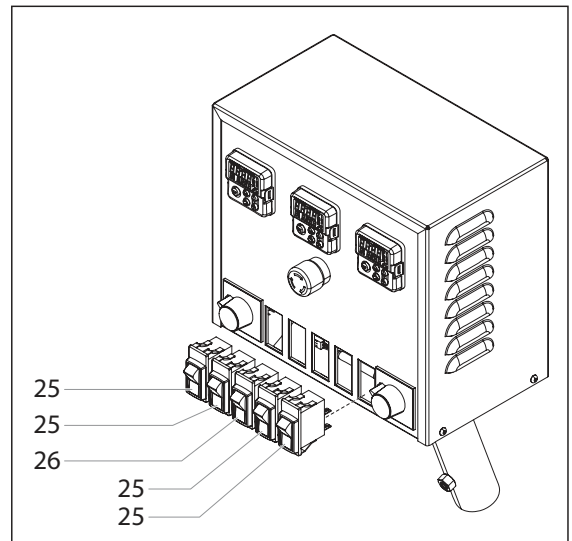
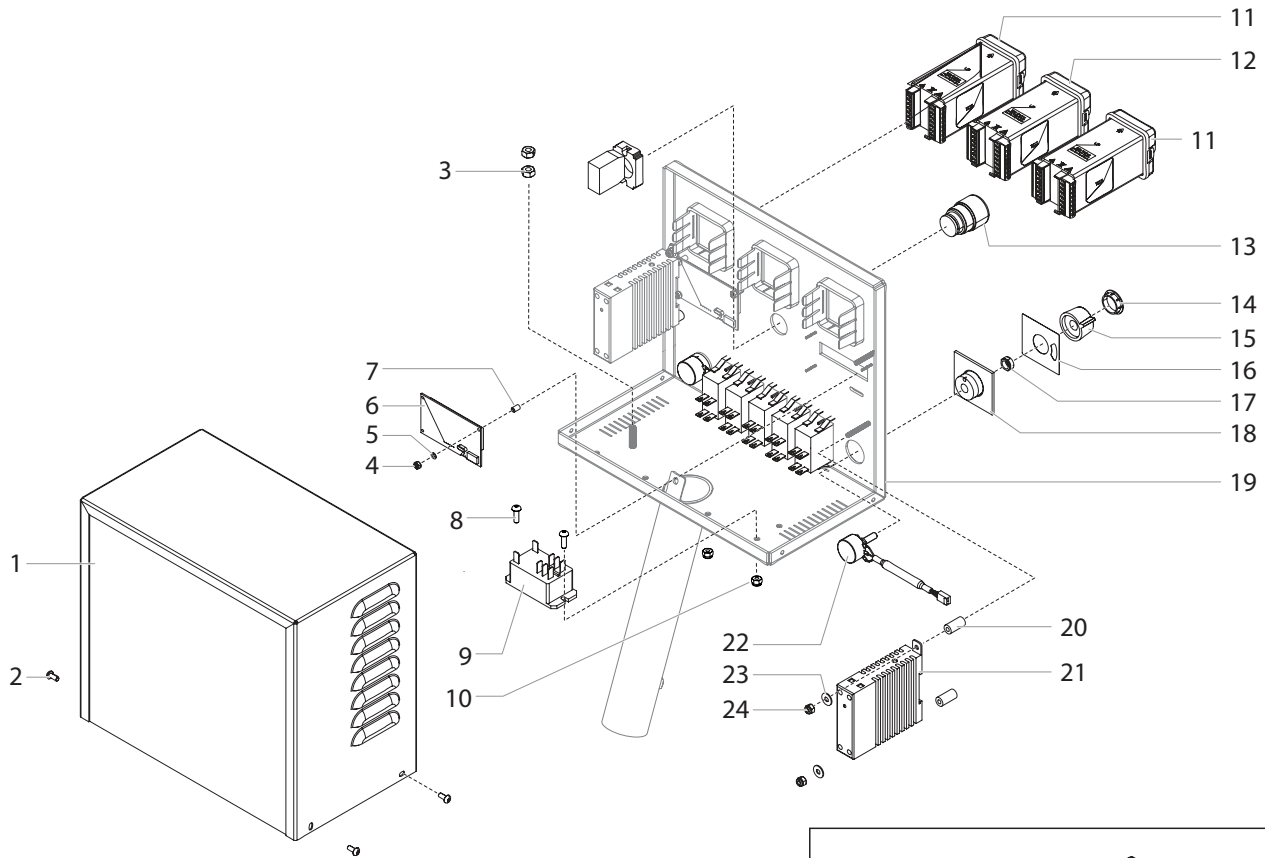



Pos.	Helix A / B 0138010	Helix A / B 0138057	Helix A / B 2405634	Helix A / B 2407046	Description
1	0138462A	0138462A	0138462A	0138462A	Display cover
2	730-260	730-260	730-260	730-260	Screw (4)
3	9812335	9812335	9812335	9812335	Nut (2)
4	9812334	9812334	9812334	9812334	Nut (6)
5	9822646	9822646	9822646	9822646	Washer (6)
6	805-401	805-401	805-401	805-401	Display (2)
7	0138527	0138527	0138527	0138527	Spacer (6)
8	-----	700-139	700-139	-----	Screw (2)
9	-----	0522577	0522577	-----	Relay, 30A
10	-----	855-914	855-914	-----	Lock nut (2)
11	0138784	0138784	0138935	0138935	Controller (2)
12	0138782	0138782	0138936	0138936	Controller
13	0522516	0522576	0522576	0522516	Emergency stop button
14	700-175	700-175	700-175	700-175	Cap (2)
15	700-159	700-159	700-159	700-159	Control knob (2)
16	0138863	0138863	0138863	0138863	Control knob label (2)
17	700-176	700-176	700-176	700-176	Nut with seal (2)
18	704-293	704-293	704-293	704-293	Mounting plate (2)
19	0138457A	0138457A	0138457A	0138457A	Display weldment with label
20	0138510	0138510	0138510	0138510	Spacer (4)
21	0522524	0522524	0522524	0522524	Relay (2)
22	0522543	0522543	0522543	0522543	Potentiometer assembly
23	9822631	9822631	9822631	9822631	Washer (4)
24	855-914	855-914	855-914	855-914	Nut (4)
25	0522515	0522515	0522515	0522515	Circuit breaker, 12A (4)
26	0522513	0522513	0522513	0522513	Circuit breaker, 1.5A

FLUID SECTION

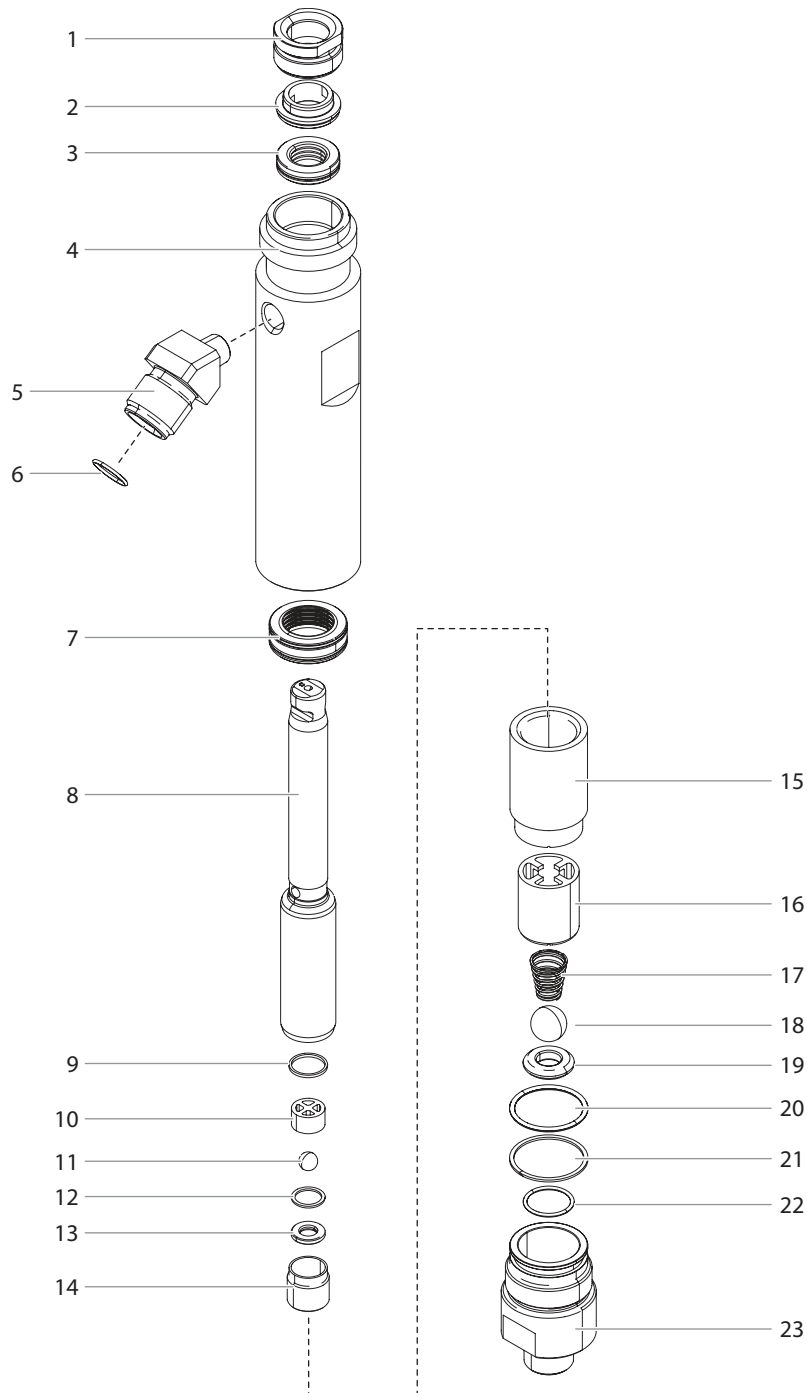

Pos.	Helix A 0138039A	Helix B 0138277A	Description
1	0138899	805-545	Retainer
2	805-551	805-551	Spacer
3	0509123A	0509123A	Upper packing
4	0138898	805-519	Cylinder
5	805-587	805-587	Fitting
6	9871189	9871189	O-ring
7	0558582A	0558582A	Lower packing
8	0558564A	0558564A	Piston rod
9	800-348	800-348	Upper seal
10	0507452	0507452	Upper ball guide
11	9841502	9841502	Outlet valve ball
12	0507454	0507454	Washer
13	0294516	0294516	Outlet valve seat
14	800-336	800-336	Outlet valve retainer
15	0509511	0509511	Adapter
16	0138411	0138411	Lower ball guide
17	0138406	0138406	Spring
18	51519	51519	Inlet valve ball
19	00310	00310	Inlet valve seat
20	800-332	800-332	O-ring, Viton
21	800-333	800-333	Backup ring
22	9871218	9871218	Inlet valve seal
23	0138481	0138481	Inlet valve housing
	805-267A	805-267A	Piston assembly (includes items 8-14)
	0558981	0558981	Fluid section service kit (includes items 2-3, 7, 9, 11, 13, 18 and 20-22)

CART ASSEMBLY

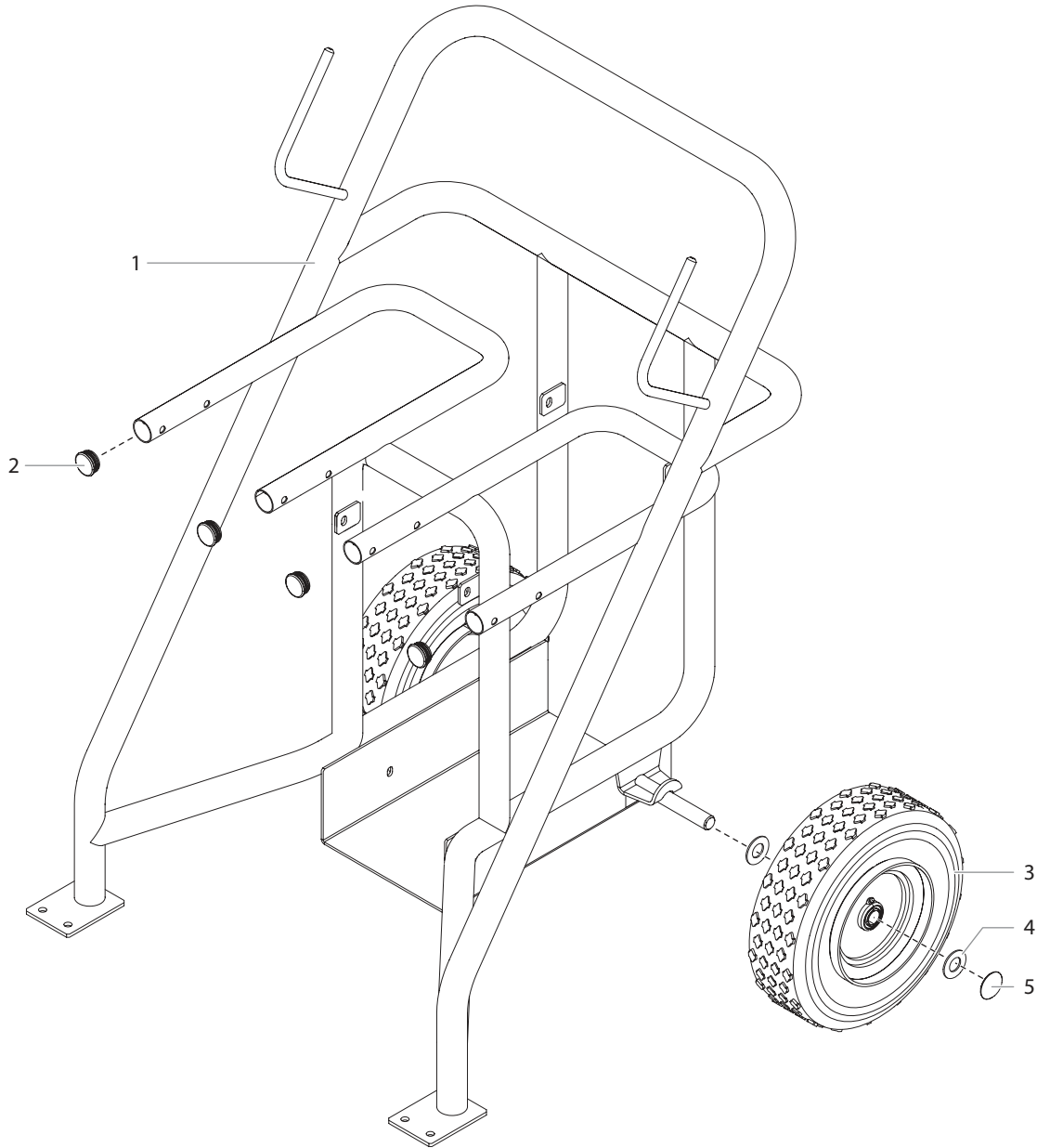

Pos.	Helix A / B	Description
1	0138288A	Cart assembly (includes items 3-5)
2	0294635	Plug (4)
3	670-109	Wheel (2)
4	0295687	Spacer (4)
5	800-019	Axle cap (2)

## PRIME/SPRAY VALVE ASSEMBLY

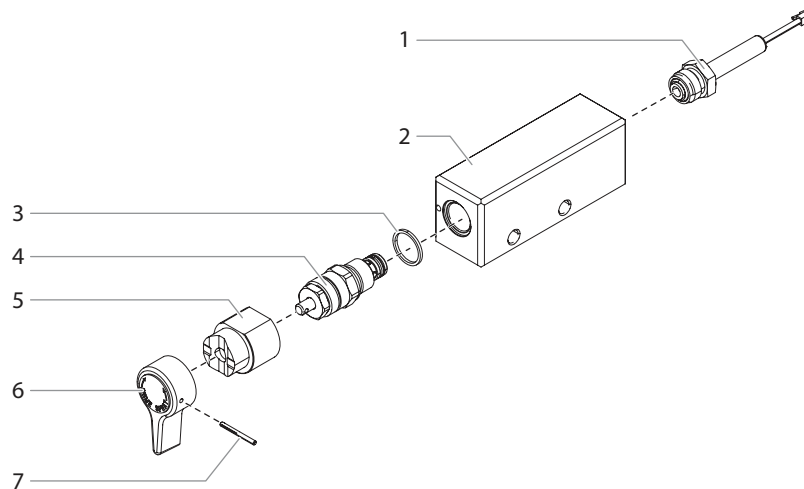

Pos.	Helix A	Helix B	Description
1	800-437	800-437	Transducer assembly
2	0138424A	0138424A	PRIME/SPRAY assembly manifold
3	700-537	700-537	Gasket
4	0558727	0558727	Bypass valve assembly, includes item 3
5	700-252B	700-252B	Cam base
6	0138499	0138498	Relief valve knob
7	700-759	700-759	Groove pin

SUREFIRE™ HEATER BLOCK

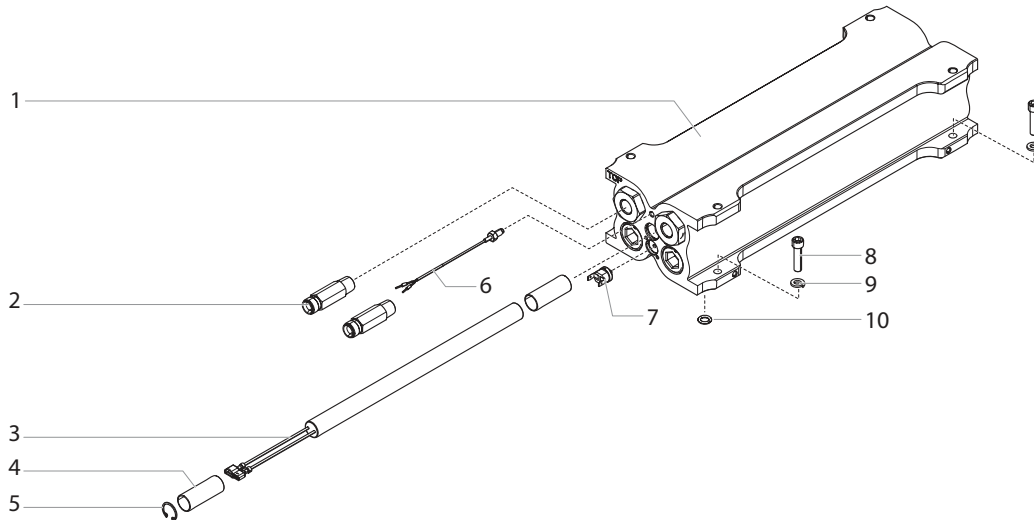

Pos.	Helix A / B	Description
1	0138638A	Heater block, top (includes item 2 and 10)
	0138639A	Heater block, middle (includes item 2)
	0138640A	Heater block, bottom (includes item 2 and 10)
2	0138469	Reducer fitting (2)
3	0138470	Firestick rod
4	0138497	Spacer (2)
5	9822558	Retainer ring (2)
6	0138501	Thermocouple
7	0138492	Thermostat
8	9805280	Screw (4)
9	860-002	Washer (4)
10	9871228	O-ring (2)

# WARRANTY

Titan Tool, Inc., (“Titan”) warrants that at the time of delivery to the original purchaser for use (“End User”), the equipment covered by this warranty is free from defects in material and workmanship.

**SYSTEM WARRANTY:**

**Two Year (24 months) Manufacturer’s Defects:**

With the exception of any special, limited, or extended warranty published by Titan, Titan’s obligation under this warranty is limited to replacing or repairing without charge those parts which, to Titan’s reasonable satisfaction, are shown to be defective within twenty-four (24) months after sale to the End User. This warranty applies only when the unit is installed and operated in accordance with the recommendations and instructions of Titan.

This warranty does not apply in the case of damage or wear caused by abrasion, corrosion or misuse, negligence, accident, faulty installation, substitution of non-Titan component parts, or tampering with the unit in a manner to impair normal operation. This warranty excludes normal wear items and consumables such as, filters, piston, packings, tips, etc.

**HELIX MOTOR WARRANTY:**

**Four Year (48 months) Manufacturer’s Defects:**

With the exception of any special, limited, or extended warranty published by Titan, Titan’s obligation under this warranty is limited to replacing or repairing without charge the Helix Motors, to Titan’s reasonable satisfaction, are shown to be defective within forty-eight (48) months after sale to the End User. This warranty applies only when the unit is installed and operated in accordance with the recommendations and instructions of Titan.

This warranty does not apply in the case of damage or wear caused by abrasion, corrosion or misuse, negligence, accident, faulty installation, substitution of non-Titan component parts, or tampering with the unit in a manner to impair normal operation.

Defective parts are to be returned to an authorized Titan sales/service outlet. All transportation charges, including return to the factory, if necessary, are to be borne and prepaid by the End User. Repaired or replaced equipment will be returned to the End User transportation prepaid.

THERE IS NO OTHER EXPRESS WARRANTY. TITAN HEREBY DISCLAIMS ANY AND ALL IMPLIED WARRANTIES INCLUDING, BUT NOT LIMITED TO, THOSE OF MERCHANTABILITY AND FITNESS FOR A PARTICULAR PURPOSE, TO THE EXTENT PERMITTED BY LAW. THE DURATION OF ANY IMPLIED WARRANTIES WHICH CANNOT BE DISCLAIMED IS LIMITED TO THE TIME PERIOD SPECIFIED IN THE EXPRESS WARRANTY. IN NO CASE SHALL TITAN LIABILITY EXCEED THE AMOUNT OF THE PURCHASE PRICE. LIABILITY FOR CONSEQUENTIAL, INCIDENTAL OR SPECIAL DAMAGES UNDER ANY AND ALL WARRANTIES IS EXCLUDED TO THE EXTENT PERMITTED BY LAW.

TITAN MAKES NO WARRANTY AND DISCLAIMS ALL IMPLIED WARRANTIES OF MERCHANTABILITY AND FITNESS FOR A PARTICULAR PURPOSE WITH RESPECT TO ACCESSORIES, EQUIPMENT, MATERIALS OR COMPONENTS SOLD BUT NOT MANUFACTURED BY TITAN. THOSE ITEMS SOLD, BUT NOT MANUFACTURED BY TITAN (SUCH AS GAS ENGINES, SWITCHES, HOSES, ETC.) ARE SUBJECT TO THE WARRANTY, IF ANY, OF THEIR MANUFACTURER. TITAN WILL PROVIDE THE PURCHASER WITH REASONABLE ASSISTANCE IN MAKING ANY CLAIM FOR BREACH OF THESE WARRANTIES.

Note on disposal:

In observance of the European Directive 2002/96/EC on waste electrical and electronic equipment and implementation in accordance with national law, this product is not to be disposed of together with household waste material but must be recycled in an environmentally friendly way!



Titan or one of our dealers will take back your used Titan waste electrical or electronic equipment and will dispose of it for you in an environmentally friendly way. Please ask your local Titan service centre or dealer for details or contact us direct.



**TITAN<sup>®</sup>**

**HELIX<sup>™</sup>**

**FR 28**

**UNITED STATES SALES & SERVICE**

**WEB:** [www.titantool.com](http://www.titantool.com)

**PHONE:** 1-844-458-1215

**FAX:** 1-800-528-4826

1770 Fernbrook Lane

Minneapolis, MN 55447

**INTERNATIONAL**

**WEB:** [www.titantool-international.com](http://www.titantool-international.com)

**EMAIL:** [international@titantool.com](mailto:international@titantool.com)

**FAX:** 1-763-519-3509