



# TITAN<sup>®</sup>

## FIELD & PAVEMENT



SCAN FOR  
DIGITAL COPY



# SPRAYING **REDEFINED**







# THE BEST & LONGEST WARRANTY IN THE INDUSTRY

## Four-Year Manufacturer's Defect

We pledge that our sprayers are free from defects in materials and workmanship. This excludes normal wear items and consumables such as filters, piston, packings, spray tips, spray guns, hoses, etc.

## Lifetime DuraLife HE and PMDC Motor Warranty

If the motor fails for any reason (including wear) for as long as you own the sprayer, we will replace the motor at no cost to you.

## Limited Lifetime DCX Motor Warranty

If the motor fails from normal usage for as long as you own the sprayer, we will replace the motor at no cost to you.

## Gas Engine Warranty

Three-year Honda® and two-years all others.

## Two-Year Turbine Warranty

## Lifetime Drive Train Warranty

If the drive train fails from normal usage for as long as you own the sprayer, we will replace the drive train at no cost to you.

## Lifetime Warranty on PermaStroke Technology™ Fluid Pump

Get a lifetime warranty on the PermaStroke Technology fluid pump. If the fluid pump fails for any reason (including wear) for as long as you own the sprayer, we will replace the fluid pump at no cost.

## 35-Day Satisfaction Guarantee

If for any reason the sprayer does not perform up to your expectations within 35 days, the sprayer can be exchanged for the identical model or full credit toward the purchase of a Titan sprayer of larger size and value.

## Express Parts Program

- ▶ More than 550 Authorized Service Centers nationwide
- ▶ The most common repair parts are guaranteed to be in stock 100% of the time
- ▶ If for any reason your preferred Authorized Service Center is out of stock, free 2nd day air is available when ordered by 3:00 pm (EST)

## OUR MISSION

When your business depends on the tools you use,  
you need to be able to count on the people who make them.

Our relentless commitment to helping every professional painter  
be their best leads to better work, improved ROI and growing business.

**FOR WATER-BASED  
PRODUCTS ONLY**

CLUTCH DRIVEN  
**POWRLINER™**  
**850**

**0.33 GPM**



**Folding Handle**  
Makes storage and transportation easy

**5-Gallon Bucket Ready**  
Eliminates dedicated paint tank and simplifies cleaning (bucket not included)

**Reversible Gun Mount**  
Stripe off either front or rear wheel

Recommended for light, periodic-duty on athletic fields and small parking lots.

**Features:**

**Lightweight and Compact**  
Reduces operator fatigue and simple to transport

**DirectLink™ Pressure Control**  
Adjust operating pressure from 100–3000 psi

**AutoOiler™**  
Provides lubrication to fluid section of pump

**Removable Gun**  
Makes stenciling quick and easy

**Durable Tires**  
Special polymer design provides smooth performance

**Adjustable Front Wheel**  
Locks sprayer in either a straight line or allows free-wheel striping

**Available Upgrades:**

**Front Wheel Release Kit**  
293970

Release the front wheel from a locked to a fully-rotating position by simply activating the handlebar lever

**PowrLiner 850**

The PowrLiner 850 is designed for entry-level contractors, sports turf managers, and maintenance personnel for use on pavement, grass, and turf surfaces. It is an easy-to-use, entry-level line striper capable of high pressure spraying on smaller jobs. With its lightweight and compact design, it is simple to transport and fits into most automobile trunks. It is perfect for any organization or municipal budget.

SPECIFICATIONS	
	<b>PowrLiner 850</b>
Engine	37.7cc 4-stroke
Maximum Fluid Pressure	3000 psi (20.7 MPa)
Flow Rate	0.33 gpm (1.3 lpm)
Maximum Tip Size (1-gun)	Field Marking: 0.023" Traffic Marking: 0.019"
Weight	65 lbs (30 kg)
Part Number	0290005A



Includes LX-40 gun and 417 line striping tip.



# SEALED HYDRAULIC DRIVEN STRIPERS

Titan offers multiple PowrLiners that utilize hydraulic pump technology for heavy-duty, long-term use on medium, large and giant scale striping projects.

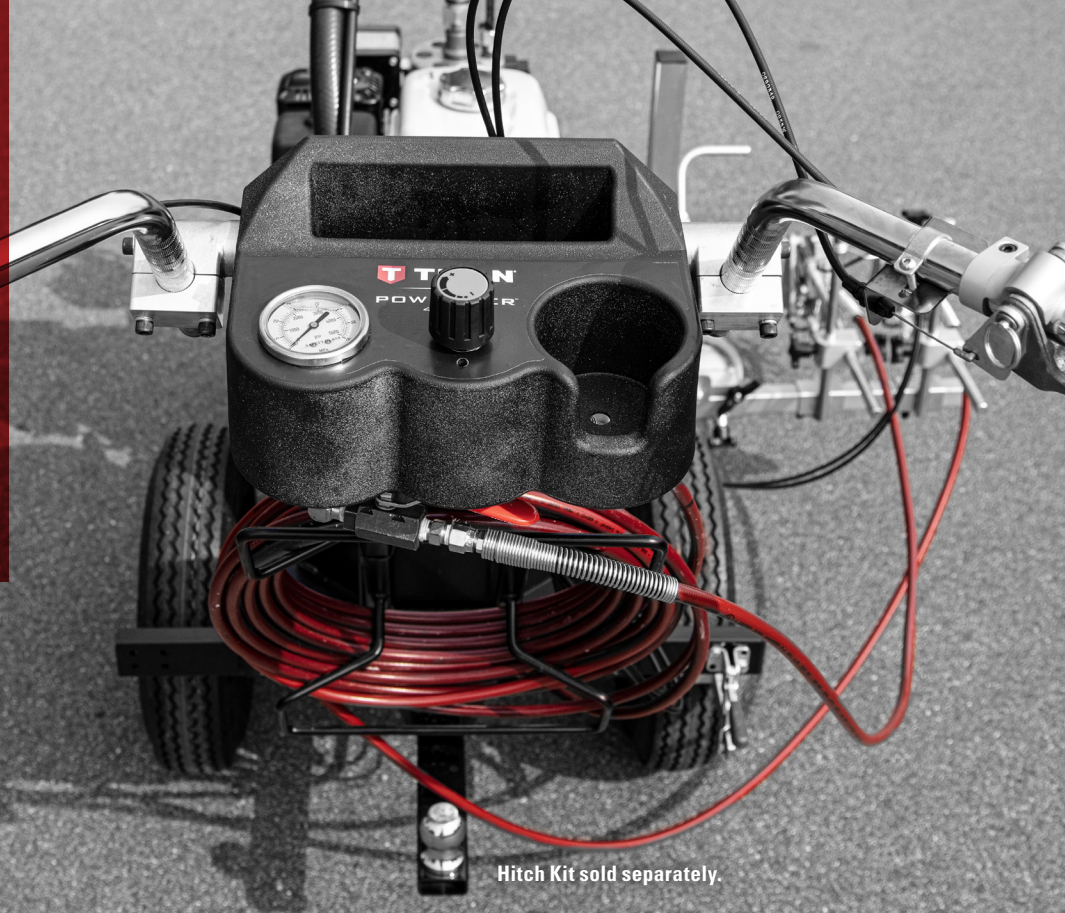

Hitch Kit sold separately.

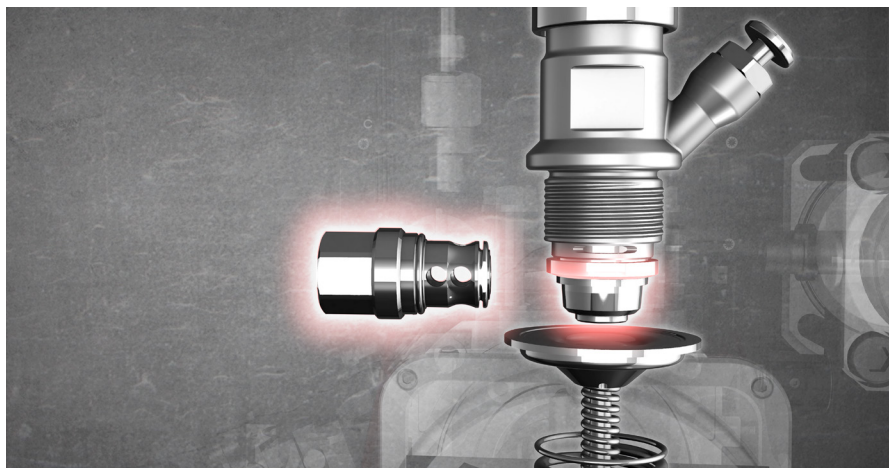

## PERMASTROKE TECHNOLOGY™

ELITE PERFORMANCE AND ULTIMATE DURABILITY

### Unbeatable Performance

- ◆ Delivers consistent pressure and zero hour glassing for an ideal spray pattern
- ◆ Easy priming guaranteed every time through the Sureflo™ Pusher valve
- ◆ Provides ideal fan patterns at pressures from 300 to 3300 psi, including small and large spray tip sizes
- ◆ Ultra smooth operation and consistency guaranteed with FlatLine Pulsation Dampener™

### Unmatched Durability and Reliability

- ◆ Offers peace of mind with PermaStroke Technology, no pistons, packings, or cylinders to wear out and no clutch to replace
- ◆ Quickly field serviceable, change out the cartridge-style inlet and outlet valves in less than 5 minutes with common tools
- ◆ Protected by Titan's WearGuard® Elite Lifetime Fluid Pump Warranty



### PowrCenter™ Dashboard

Convenient access to pressure control knob, tip holder and cup holder.

Available on PowrLiner 4500 only.



# SEALED HYDRAULIC POWRLINER™ 3500/3500S

**0.75 GPM**

Recommended for medium and large-sized projects on all parking lots and athletic fields.

## Features:

### Sureflo Pusher Valve

Makes system priming easy

### FlatLine Pulsation Dampener

Eliminates pressure fluctuations to avoid hour glassing

### No-Spill Pump Filter

Vertical design retains coating during removal

### Large 16" Pneumatic Tires

Increases portability and makes traveling over rough surfaces easier

### Swing Back Design

Increases operator leverage and reduces fatigue

### Heavy Duty Frame

Resists harsh chemicals and corrosion

## Available Upgrades:

### Dedicated Stencil Gun Kit for PowrLiner 3500 (P/N 2418165)

Spray out stencils without having to remove the striping gun from the gun holder.

### Optional Ride-On

#### LazyLiner™ Driver (see page 9)

Finish jobs up to four times faster and increase operator comfort



**PowrLiner 3500:** Includes RX-80 gun, 419 line striping tip, and SC-6+ 517 tip.

**PowrLiner 3500S:** Includes RX-80 gun with 419 line striping tip plus dedicated RX-80 gun with 18" extension and SC-6+ 517 tip for stenciling.



Powered by  
**HONDA**

- ▶ Exceptionally quiet
- ▶ Smooth performance with lower vibration

**PowrCenter Dashboard**

**Dashboard**

Convenient features include tip holder and cup holder.

**Dedicated Stencil Gun**

Dedicated second gun makes stenciling quick and easy

## POWRLINER 3500S ▲

## PowrLiner 3500/3500S

The Titan PowrLiner 3500 and 3500S sealed hydraulic line strippers deliver sharp and consistent line quality on a variety of surfaces including concrete, parking lots, and athletic fields. Featuring the revolutionary PermaStroke Technology which has no pistons, packings, cylinders or clutch to replace and backed by the WearGuard Elite Lifetime Fluid Pump Warranty, they are simple to operate and field serviceable, keeping contractors on the job.

SPECIFICATIONS	PowrLiner 3500	PowrLiner 3500S
Engine	Honda® GX120	Honda GX120
Maximum Fluid Pressure	3300 psi (22.8 MPa)	3300 psi (22.8 MPa)
Flow Rate	0.75 gpm (2.8 lpm)	0.75 gpm (2.8 lpm)
Maximum Tip Size (1-gun)	0.027"	0.027"
Maximum Tip Size (2-gun)	----	----
Weight	192 lbs (87 kg)	201 lbs (91 kg)
Part Number	537015	2417440



# HYDRAULIC DRIVEN STRIPERS

Titan offers multiple PowrLiners that utilize hydraulic pump technology for heavy-duty, long-term use on medium, large and giant scale striping projects.



Phone, headphones, charger, and cup are for illustrative purposes only.

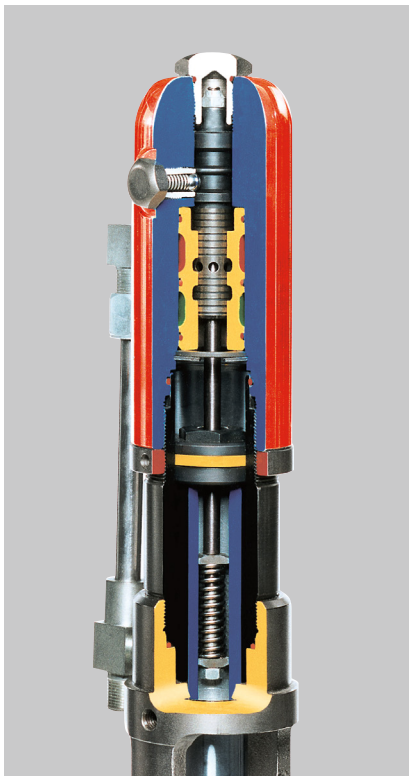

## Spee-flo® HydraDrive™

- Reliable, smooth, slow-stroking hydraulic drive greatly extends the operational life of the sprayer
- External-hydraulic fluid porting with upgraded fittings allows for quick troubleshooting and simplified maintenance
- SAE O-ring fitting and precision rod alignment ensure maximum pump life

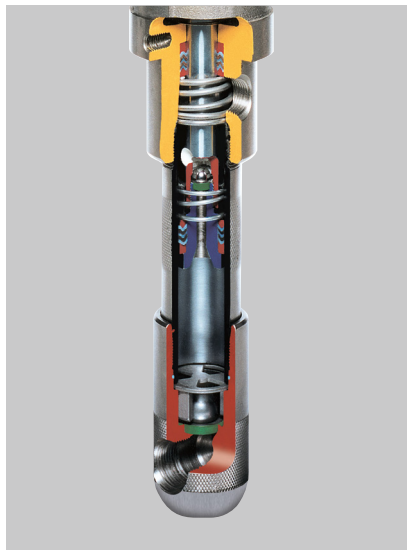

## Severe Service™ 900 Pump

- Cylinder and piston rod are tempered with a proprietary heat-treating process that increases pump life up to 150% longer than competitive pumps
- Self-adjusting packings prevent over-tightening and help prevent premature wear
- Foot valve removes easily for faster cleaning and easy maintenance
- Reversible inlet and outlet seats have twice the lifespan of ordinary outlet seats and extra large ball valves ensure efficient pump operation and longer unit life
- Heavy-duty prime/spray valve ensures consistent, increased flow and faster pump priming



## PowrCenter™ Dashboard

Convenient and easy-to-use, including the pressure control knob, tip holder, phone charging port and cup holder.



## DeadLock Handlebars

Infinitely adjustable in 3 planes.



## 2 hp Electric Converto Kit

Change from gas to electric power in minutes, when gas engines are not permitted.

For use only with PowrLiner 4950, 4955 and all XLT units.



HYDRAULIC  
**POWRLINER**  
 4955/6955/8955

**1.25/2.10/2.50 GPM**

Recommended for large scale, full-time duty on airports, roads, parking lots and athletic fields.

**Features:**

**Precise Pressure Control**

Adjust operating pressure from 400 to 3300 psi to reduce hourglassing

**Heavy Duty Frame**

Resists harsh chemicals and corrosion

**Large 16" Pneumatic Tires**

Highway-rated wheel bearings promote better steering and smoother performance, even over rough surfaces

**12 Gallon Paint Hopper**

Spend more time striping and less time refilling

**Electric Engine Start**

Quick and convenient way to start projects (PL6955 and PL8955 only)

**Available Upgrades:**

**Optional Ride-On LazyLiner™ Driver** (see page 9)

Finish jobs up to four times faster and increase operator comfort



Includes two S-3 Stainless Steel spray guns, 419 line striping tips, and SC-6+ 517 tip.

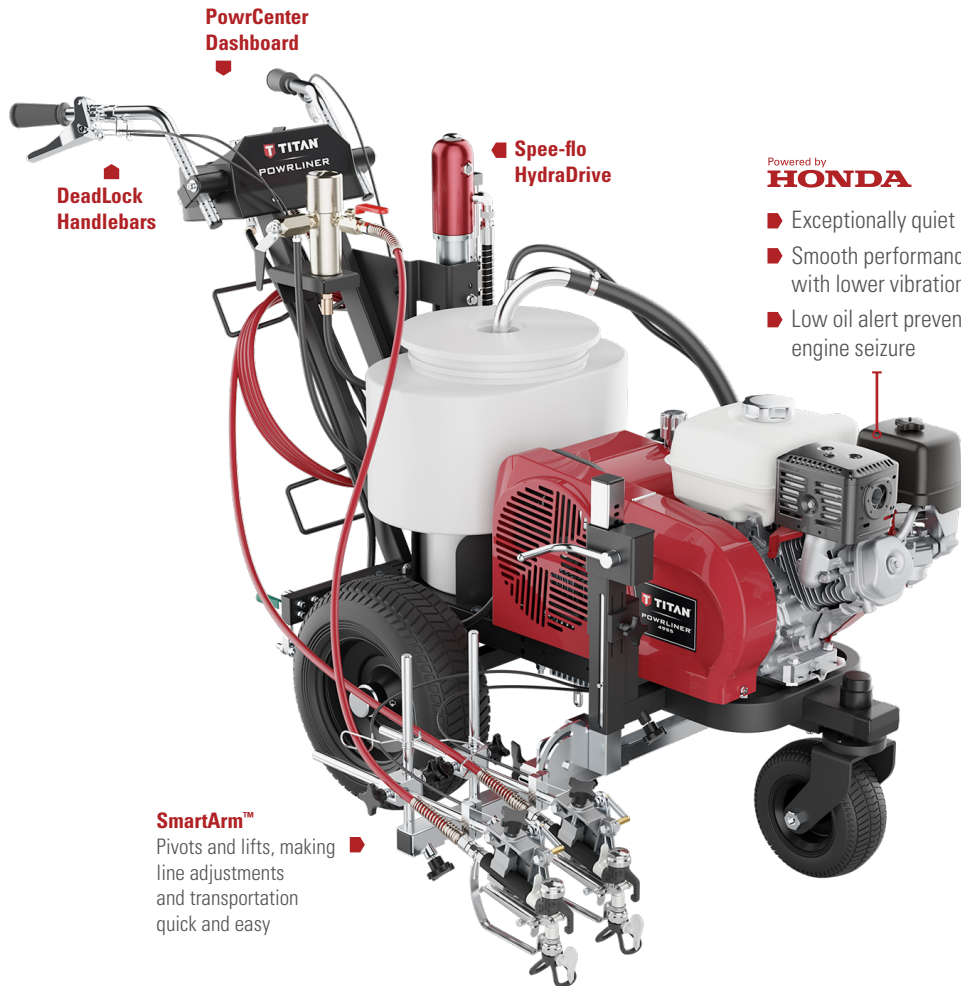

**PowrLiner 4955/6955/8955**

Larger projects require more power and output. These line strippers are the workhorse machines of the industry, designed for ease of use and simple operation on major projects that require maximum performance with minimum downtime and maintenance.

	PowrLiner 4955	PowrLiner 6955	PowrLiner 8955
<b>SPECIFICATIONS</b>			
Engine	Honda GX120	Honda GX160 with electric start	Honda GX200 with electric start
Maximum Fluid Pressure	3300 psi (22.8 MPa)	3300 psi (22.8 MPa)	3300 psi (22.8 MPa)
Flow Rate	1.25 gpm (4.7 lpm)	2.10 gpm (7.9 lpm)	2.50 gpm (9.5 lpm)
Maximum Tip Size (1-gun)	0.034"	0.047"	0.054"
Maximum Tip Size (2-gun)	0.025"	0.031"	0.038"
Weight	324 lbs (147 kg)	339 lbs (154 kg)	339 lbs (154 kg)
Part No.	0290052H	0290053H	0290054H



# ENGINEERED FOR PERFECT LINES

Titan's line striping tips provide razor sharp line edges, consistent line width, and uniform film thickness. They also reduce wasted paint and increase striper profits.



## EASY-TO-UNDERSTAND TIP SIZES

- ▶ Part Number: 697-XXY
- ▶ X = Width of stripe (inches) when sprayed 6" from surface
- ▶ YY = Orifice size in thousandths of an inch
- ▶ Example: 419 = 4" wide stripe with a 0.019" orifice

## Line Striping Tips 697-XXX

FAN PATTERN WIDTH	INCHES	MM	ORIFICE SIZE (INCHES)							
			0.013	0.015	0.017	0.019	0.021	0.023	0.025	0.027
2		51		215	217	219				
4		102	413	415	417	419	421	423		427
6		152		615	617	619	621			
8-10		203-254					821	823		
Flow (GPM)		---	0.18	0.24	0.31	0.39	0.47	0.57	0.67	0.78
Flow (LPM)		---	0.68	0.91	1.17	1.47	1.78	2.15	2.53	2.95

Maximum Working Pressure: 5000 psi (34.5 MPa)



## TR<sup>2</sup> Versatile Line Striping Tips

Change between striping (narrow) and stenciling (wide) fan patterns – with a simple twist of one tip.

STRIPING TIP SIZE	STENCIL TIP SIZE	FLAG	FILTER COLOR	PART NO.
417	517	Yellow	White	694-1708517
419	519	Yellow	White	694-1908519
421	621	Yellow	White	694-2108621
423	623	Yellow	White	694-2308623



▶ TR<sup>2</sup> Line Striping Tip

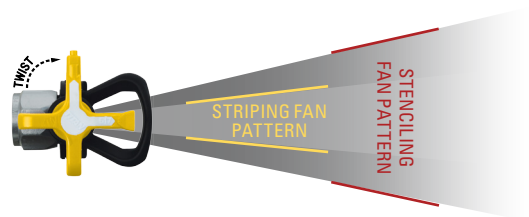



# LAZYLINER™ SERIES

Take a load off and increase productivity up to four times. An economical way to grow your business.



◀ LazyLiner Pro



▶ LazyLiner Elite

## LazyLiner Series Specifications

DESCRIPTION	LAZYLINER PRO	LAZYLINER ELITE
Part Number	0290041H	0290040H
Gas Engine	Honda GX160	Honda GX200
Start	Pull	Electric
Forward Speed	0 - 12 mph (0 - 19 kph)	0 - 12 mph (0 - 19 kph)
Reverse Speed	0 - 7 mph (0 - 11 kph)	0 - 7 mph (0 - 11 kph)
Multi-Position Seat (forward/back, side-to-side)	Yes	Yes
Height Adjustable Foot Pedals	Yes	Yes
Pneumatic Tires	Standard (16" x 4.5")	Heavy-Duty (16" x 6.5")
Bumper / Engine Protection Bar	Optional: Part No. 2423493	Included
100 Watt Lamp Coil Charging System	No	Yes, allows additional accessories (lasers, lights, etc.) to directly access on-board electrical power

- Compatible with PL2850, PL3500, PL3500S, PL4500, PL4900XLT, PL4950, PL4955, PL6900XLT, PL6950, PL6955, PL8900XLT, PL8950, PL8955
- Line Striper Hitch Kit required and sold separately

## LazyLiner Tray

- ▶ Carry additional items in this attachable tray
- ▶ For use on the LazyLiner Pro and Elite



ENGINE MODEL	LAZYLINER PRO	LAZYLINER ELITE
Honda	2423493 (Bumper) + 2413480 (Tray)	2413480
Subaru	0290646Z (Bumper) + 2413480 (Tray)	2413480

## Hitch Kits

DESCRIPTION	KIT PART NO.
PowrLiner 2850	0290043Z
PowrLiner 3500, 3500S, 4500	537935
PowrLiner 4955, 6955, 8955 PowrLiner 4950, 6950, 8950	2430599
PowrLiner 4900XLT, 6900XLT, 8900XLT	2430599 + 0290489A (updated axle with pre-drilled thru-holes)

LazyLiner drivers are not shipped with a hitch.



# LINE STRIPING ACCESSORIES



## LineSite™ Laser Pointer 0290175A

Great for start/stops, curb striping, executing perfectly straight lines and training new employees. High intensity green laser is easy to see in daylight.



## SureTrak™ Floating Gun Kit

759-120

- Keep guns at same height above surface for perfect lines over rough terrain
- For PL3500, 3500S, 4500, 4950, 4955, 6950, 6955, 8950 and 8955

## Turf Kit 759-155

- Absorbs bumps and disperses front weight over 2 wheels
- For PL4950, 4955, 6950, 6955, 8950, and 8955



## SideStriper® 759-150

- Stripes in tight spaces, including between vehicles
- Works with any airless striper



SmartArm Pivot System

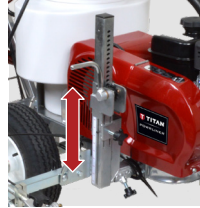

SmartArm Lift System

## SmartArm™ Assembly 290382

- Pivots and lifts, making line adjustments and transportation quick and easy
- Locks at any angle for efficient curb painting

## Striper Add-On Accessories

RECOMMENDED GUNS	
DESCRIPTION	PART NO.
LX-40 Gun	550-540
RX-80 Gun	0538110A
S-3 Gun	550060
S-3 Gun Kit	759-138
PowrLiner 2850 Gun Kit	290310
PowrLiner 3500 Stencil Gun Kit	2418165

UPGRADES	
DESCRIPTION	PART NO.
PowrLiner™ 850 Caster Release Kit	293970
12-Gallon (45-liter) Hopper	759-130
Polyethylene 5-Gallon Pail Cover	759-147

## WindGuard™ Spray Shield 290623

- Protects spray pattern from wind, minimizing overspray
- Adjustable width along with spring-loaded forgiveness on uneven surfaces



## HandiBead™ Bead Dispenser 0290953A

- Apply glass beads with consistency and accuracy, eliminating hand tossing
- Adjustable dispersion width up to 15"



## Stencil Kits

- Durable and lay flat for accurate marking
- Made from 1/8" (0.15 cm) thick polyethylene sheet



STENCIL KIT 1	
INCLUDES	PART NO.
39" (99 cm) Handicap	290932

STENCIL KIT 2	
INCLUDES	PART NO.
39" (99 cm) Handicap	290933
12" (30 cm) No Parking	
12" (30 cm) Numbers 0–9	

STENCIL KIT 3	
INCLUDES	PART NO.
42" (105 cm) Straight and Curved Arrows	290934
39" (99 cm) Handicap	
12" (30 cm) Numbers 0–9	
4", 12" (10, 30 cm) No Parking	
4", 12" (10, 30 cm) Fire Lane	
4" (10 cm) Reserved	
4" (10 cm) Visitors	



## Glass Bead Dispensing Systems

DESCRIPTION	PART NO.
1-Gun Kit w/Hopper, 4-6" width	424-826
2-Gun Kit w/Hopper, 4-6" width	424-836
2nd Gun Kit, 4-6" width	424-816
1-Gun Kit w/Hopper, 12" width	424-840
2nd Gun Kit, 12" width	424-841
Bead Dispenser bracket kit <i>(only required for PowrLiner 3500, 3500S, and 4500)</i>	290181

**Compatible Systems:** PowrLiner 2850, 3500, 3500S, 4500, 4900XLT, 4950, 4955, 6900XLT, 6950, 6955, 8900XLT, 8950, 8955



	<b>PowrLiner 850</b>	<b>PowrLiner 3500</b>	<b>PowrLiner 3500S</b>	<b>PowrLiner 4955</b>	<b>PowrLiner 6955</b>	<b>PowrLiner 8955</b>
Part Number - 1 Gun	0290005A	537015	2417440	----	----	----
Part Number - 2 Guns	----	----	----	0290052H	0290053H	0290054H
Max Delivery - Gas	0.33 gpm (1.3 lpm)	0.75 gpm (2.8 lpm)	0.75 gpm (2.8 lpm)	1.25 gpm (4.7 lpm)	2.10 gpm (7.9 lpm)	2.50 gpm (9.5 lpm)
Max Delivery - Electric	----	----	----	1.10 gpm (4.1 lpm)	----	----
Max Tip Size 1 gun - Gas	0.021"	0.027"	0.027"	0.034"	0.047"	0.054"
Max Tip Size 2 guns - Gas	----	----	----	0.025"	0.031"	0.038"
Max Tip Size 1 gun - Electric	----	----	----	0.031"	----	----
Max Tip Size 2 guns - Electric	----	----	----	0.023"	----	----
Max Operating Pressure	3000 psi (20.7 MPa)	3300 psi (22.8 MPa)	3300 psi (22.8 MPa)	3300 psi (22.8 MPa)	3300 psi (22.8 MPa)	3300 psi (22.8 MPa)
<b>Optional:</b> Electric Motor (0290115A)	----	----	----	2 hp (1.5 kW) Extended Life DC	----	----
Max Spray Speed	106 linear feet (32 m) per minute	400 linear feet (122 m) per minute	400 linear feet (122 m) per minute	511 linear feet (155 m) per minute	688 linear feet (210 m) per minute	752 linear feet (229 m) per minute
Line Width Range	2"-12" (5 cm-30.5 cm)	2"-12" (5 cm-30.5 cm)	2"-12" (5 cm-30.5 cm)	2"-24" (5 cm-61 cm)	2"-24" (5 cm-61 cm)	2"-24" (5 cm-61 cm)
Power Source	37.7cc 4-stroke Gas Engine	Honda GX120 with Pull Start	Honda GX120 with Pull Start	Honda GX120 with Pull Start	Honda GX160 with Electric Start	Honda GX200 with Electric Start
Pump Drive	Clutch Driven	Clutchless Sealed Hydraulic	Clutchless Sealed Hydraulic	Hydraulic	Hydraulic	Hydraulic
Cycle Rate	----	----	----	87 per gallon (23 per liter)	55 per gallon (15 per liter)	40 per gallon (11 per liter)
On-Board Electrical System	----	----	----	----	100 Watts	100 Watts
Paint Outlet - Filter Element	60-Mesh	60-Mesh	60-Mesh	50-Mesh	50-Mesh	50-Mesh
Paint Outlet - Filter Area	3 in <sup>2</sup> (19 cm <sup>2</sup> )	18 in <sup>2</sup> (116 cm <sup>2</sup> )	18 in <sup>2</sup> (116 cm <sup>2</sup> )	18 in <sup>2</sup> (116 cm <sup>2</sup> )	18 in <sup>2</sup> (116 cm <sup>2</sup> )	18 in <sup>2</sup> (116 cm <sup>2</sup> )
Weight - Unit	65 lbs (30 kg)	192 lbs (87 kg)	201 lbs (91 kg)	324 lbs (147 kg)	339 lbs (154 kg)	339 lbs (154 kg)
Weight - Crated	89 lbs (40 kg)	259 lbs (118 kg)	273 lbs (124 kg)	392 lbs (178 kg)	433 lbs (196 kg)	433 lbs (196 kg)
Dimensions (L x W x H) - Unit	41" x 21" x 32" (104 x 53 x 81 cm)	65" x 32.5" x 39.5" (165 x 82 x 100 cm)	65" x 32.5" x 39.5" (165 x 82 x 100 cm)	72" x 42" x 42" (183 x 107 x 107 cm)	72" x 42" x 42" (183 x 107 x 107 cm)	72" x 42" x 42" (183 x 107 x 107 cm)
Dimensions (L x W x H) - Crated	46" x 26" x 26" (116 x 66 x 66 cm)	69" x 37.3" x 49.3" (175 x 95 x 125 cm)	69" x 37.3" x 49.3" (175 x 95 x 125 cm)	69" x 37.3" x 49.3" (175 x 95 x 125 cm)	69" x 37.3" x 49.3" (175 x 95 x 125 cm)	69" x 37.3" x 49.3" (175 x 95 x 125 cm)
Gun(s) Included	One LX-40	One RX-80	One RX-80, One RX-80 with 18" extension	Two S-3	Two S-3	Two S-3
Line Striping Tip	417 (4" line by 0.017" orifice)	419 (4" line by 0.019" orifice)	419 (4" line by 0.019" orifice)	419 (4" line by 0.019" orifice)	419 (4" line by 0.019" orifice)	419 (4" line by 0.019" orifice)
SC-6+ Stenciling Tip	----	517	517	517	517	517
Airless Hose included	----	----	----	----	----	----
Other:	----	----	----	----	----	----
Gun 1:	1/4" x 50' (15 m)	1/4" x 50' (15 m)	1/4" x 50' (15 m)	1/4" x 50' (15 m)	1/4" x 50' (15 m)	1/4" x 50' (15 m)
Gun 2:	----	----	----	1/4" x 6' (1.8 m)	1/4" x 6' (1.8 m)	1/4" x 6' (1.8 m)
Stenciling Gun:	----	----	1/4" x 12' (3.7 m)	---	---	---
Repair Kit - pump	759-365	537903	537903	107-051	143-050	144-050
Repair Kit - gun	----	538215	538215	550-275	550-275	550-275
Operator's Manual	293782	537832	537832	537859	537859	537859
Warranty	2 years	4 years	4 years	4 years	4 years	4 years

\*Based on 4" (10 cm) line @ 15 mil wet film thickness and 320 linear feet per gallon coverage.





## WEARGUARD CONVENIENCE PROGRAM KEEPS YOU UP AND RUNNING

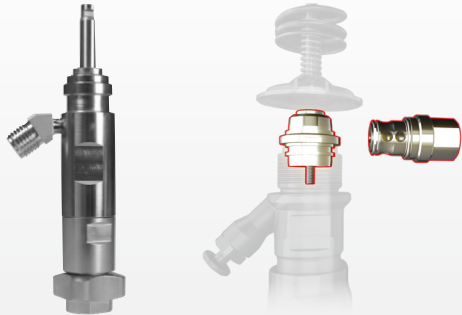

When you purchase a new Titan sprayer, you're able to take advantage of our exclusive WearGuard Convenience Program. Protect your investment by purchasing a spare fluid section or PermaStroke kit at a discounted rate. Save yourself the time and frustration of an extra trip or waiting for parts to arrive in the event that your sprayer goes down. When you have a backup fluid section or PermaStroke kit on hand, replacement can quickly be made without leaving the jobsite and doesn't require special tools. The bottom line is that WearGuard keeps you up and running.

Not interested in purchasing a spare fluid section? We also offer the option of a free packing kit on select sprayers.

For more information on pricing and how to order, go to:

[www.titanwearguard.com](http://www.titanwearguard.com)  
or scan the QR code.



## KEEP TITAN WITH YOU WHEREVER YOU GO

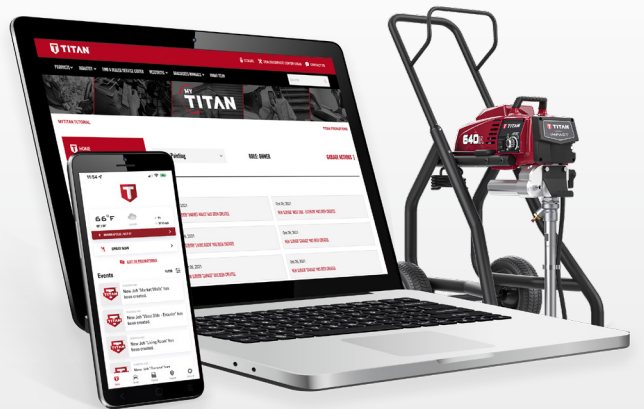

MyTitan™ gives you immediate access to all things Titan. Anywhere, anytime on your computer or mobile device. MyTitan gives you everything you need to get the most out of your sprayers, all in one place, no matter where the workday takes you. MyTitan is designed to make your life easier, your business more efficient, and your day more productive—so you can stay ahead of the game, do more in less time, and never lose track of another detail.

For more information on this new app, go to:

[www.titantool.com/mytitan-welcome](http://www.titantool.com/mytitan-welcome)  
or scan the QR code.



**THOR**  
TITAN HUB FOR ONLINE REDEMPTION

## ONLINE REWARD REDEMPTION NO CLIPPING. NO STAMPS. NO HASSLES.

For more information and to see current promotions, go to:  
[www.titantool.com/thor-promos](http://www.titantool.com/thor-promos) or scan the QR code.



All information contained in this brochure is based on the latest information available at the time of printing. Titan reserves the right to make changes at any time, without notice. Due to continuous innovation, specifications may progressively change. Contact one of our dependable sales reps or call our dedicated customer service team for more information.