

TITAN™

Focus 500

- AUS - Operating manual

1

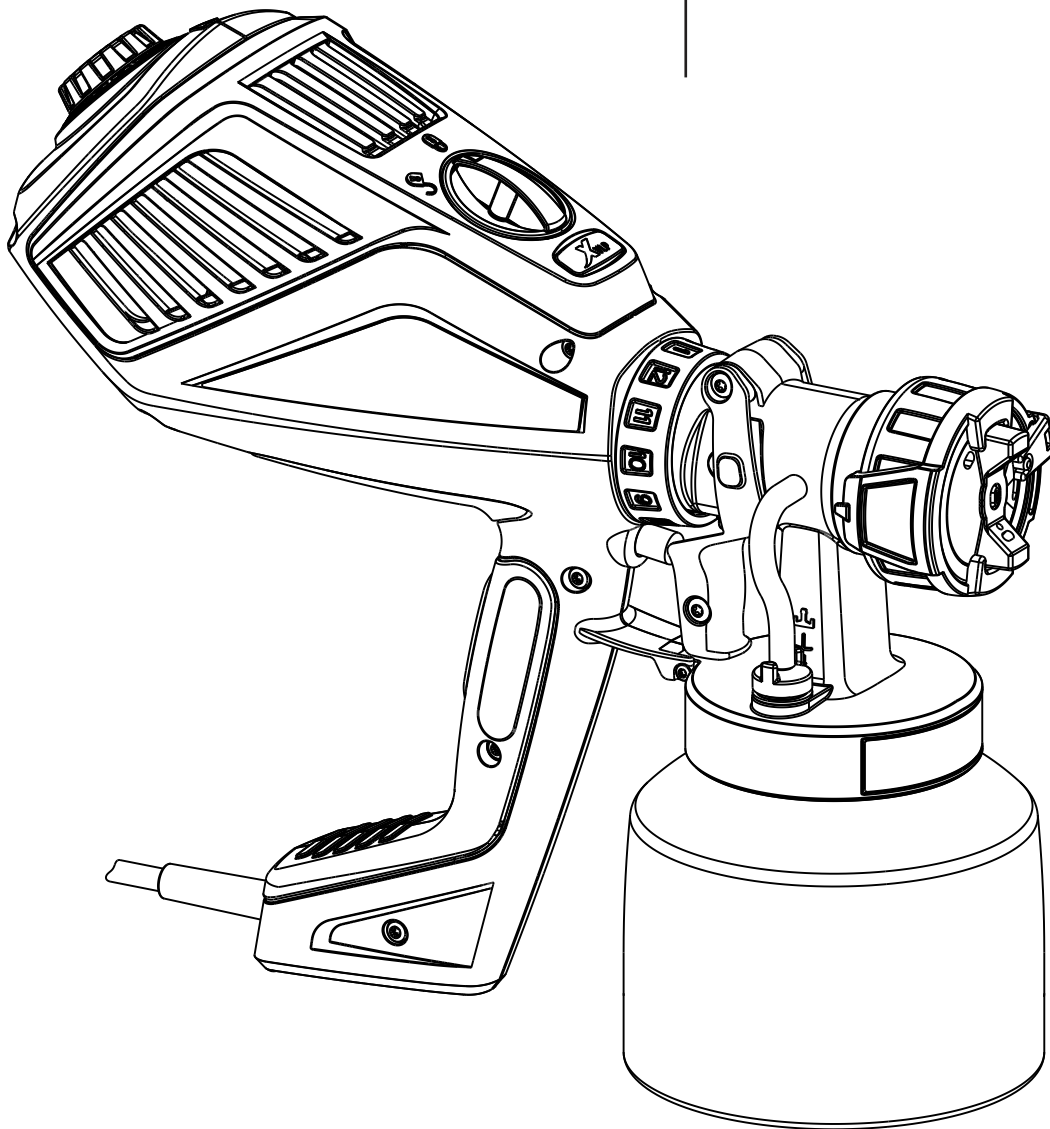

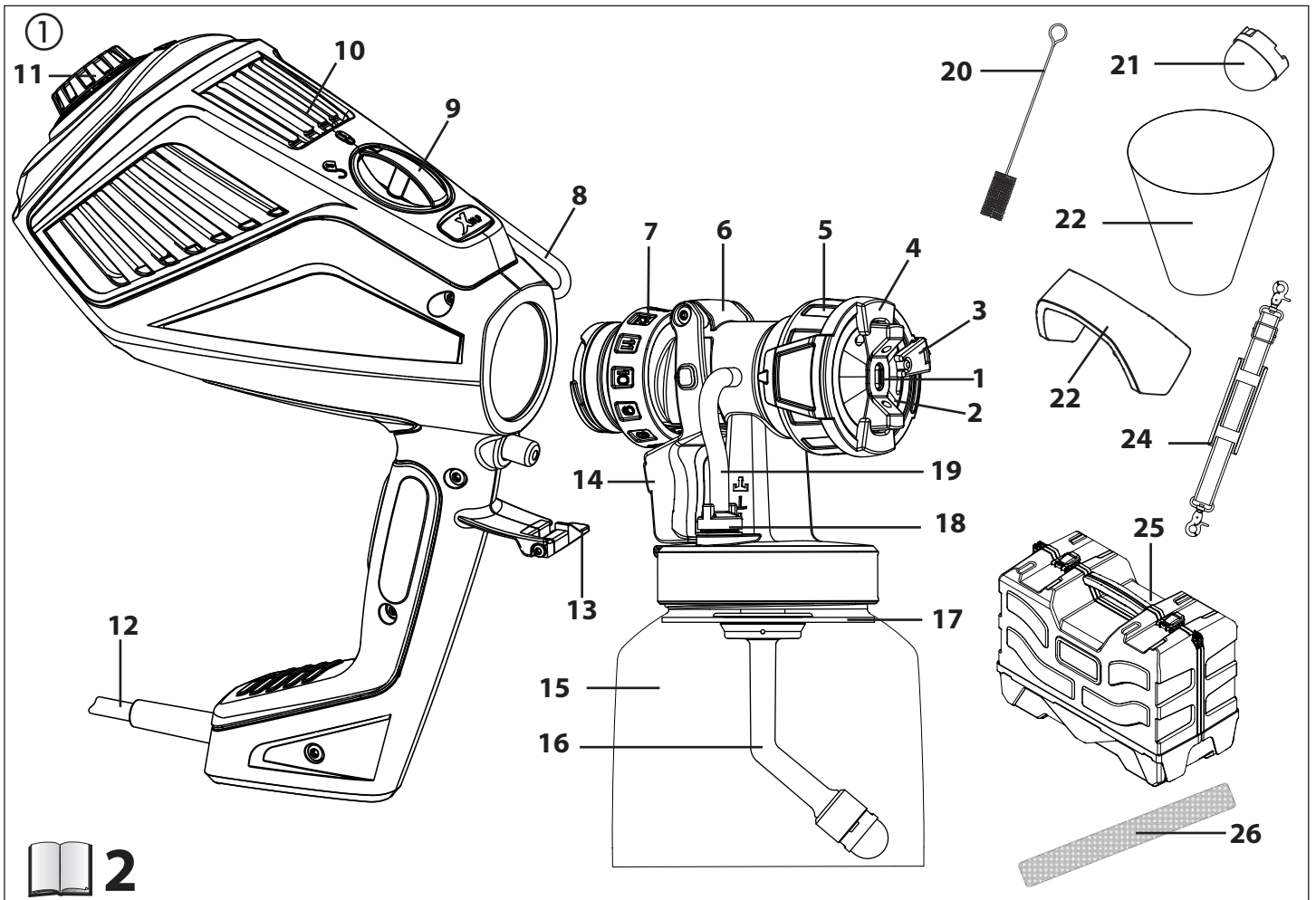

2

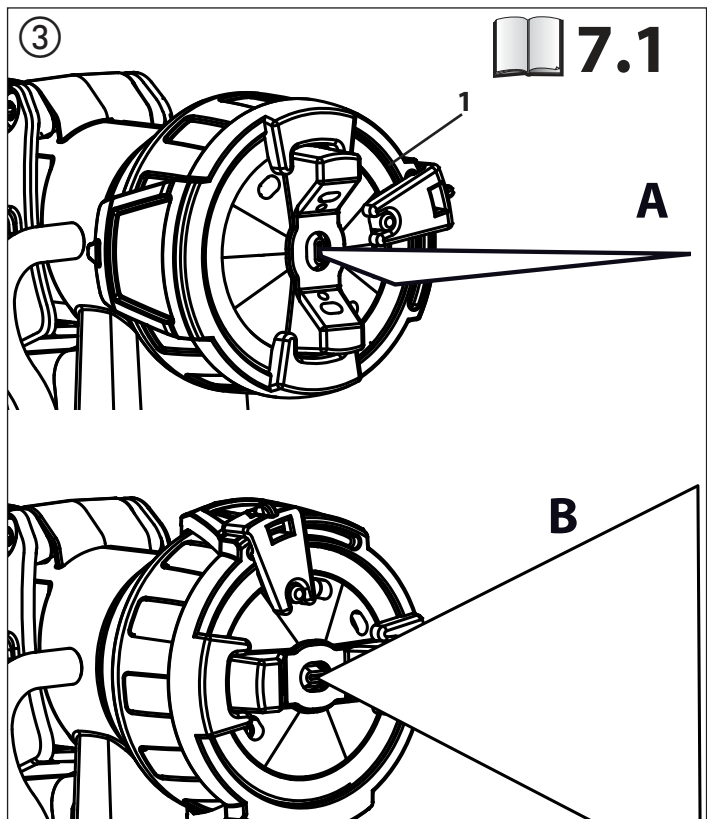
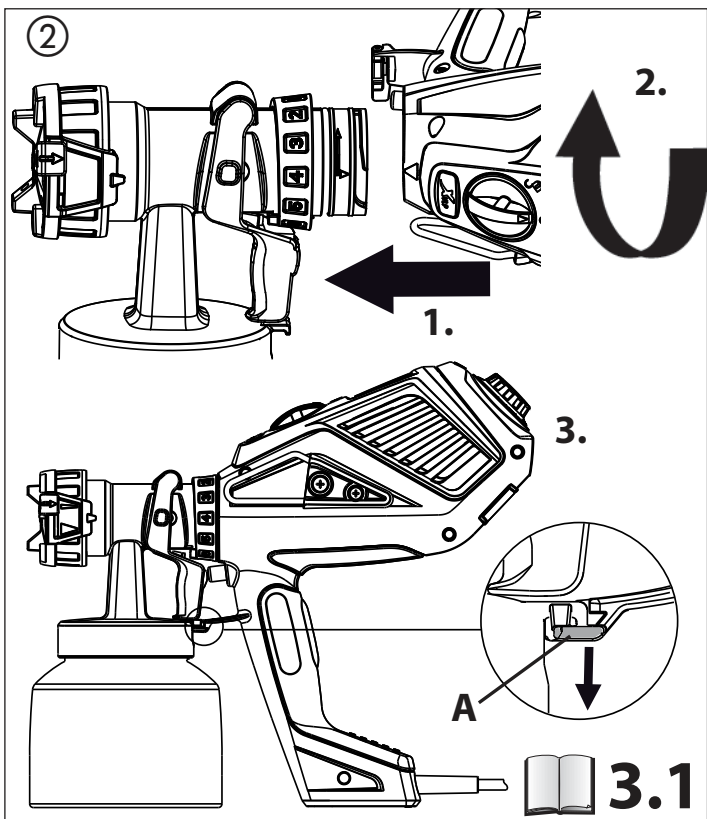

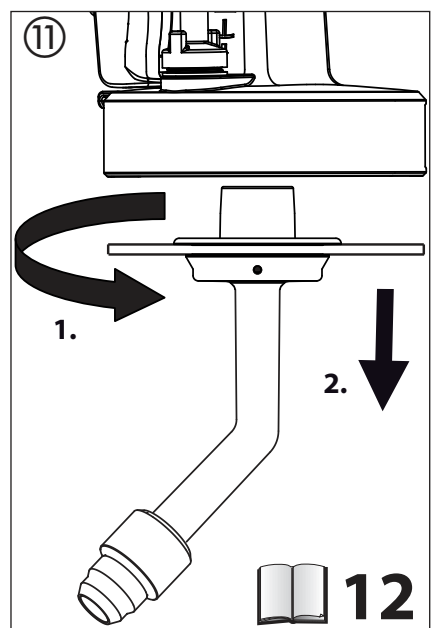
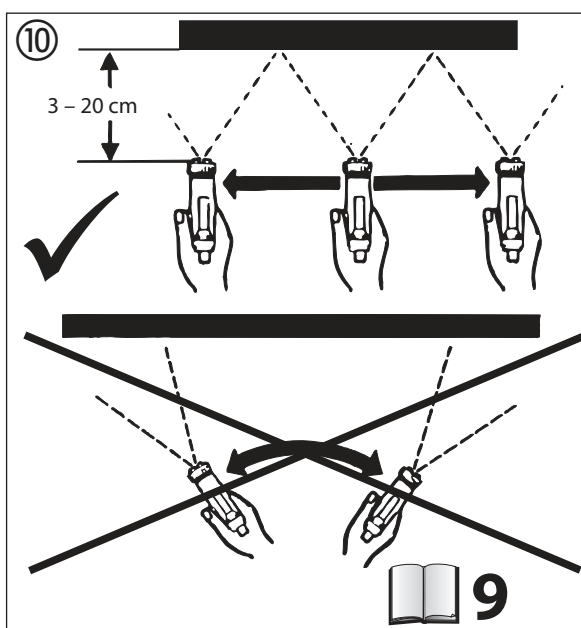
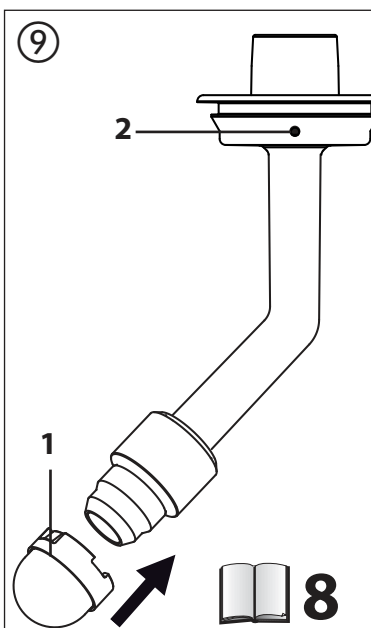
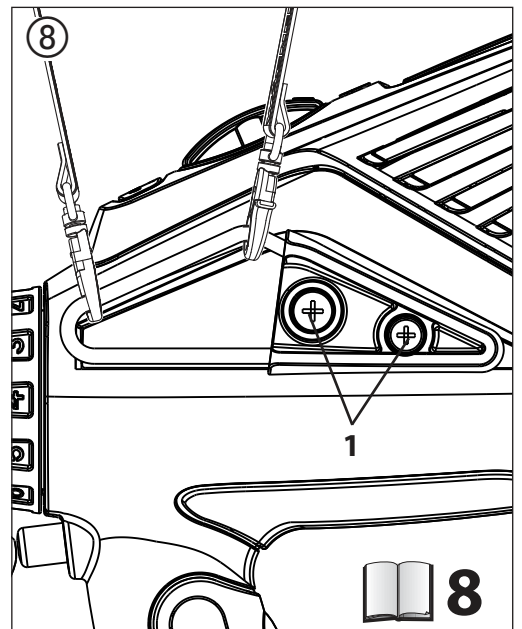
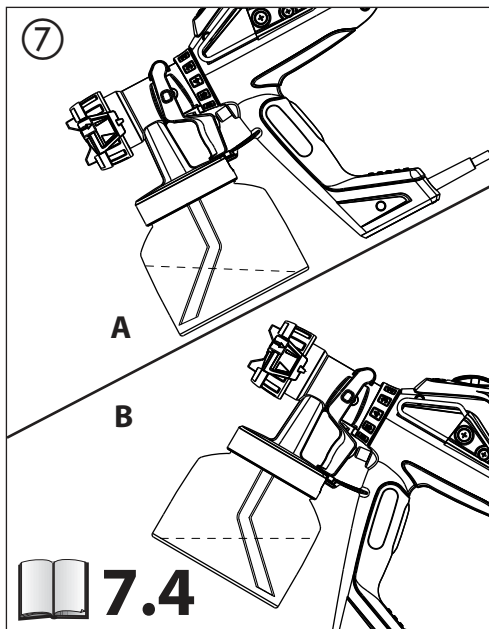
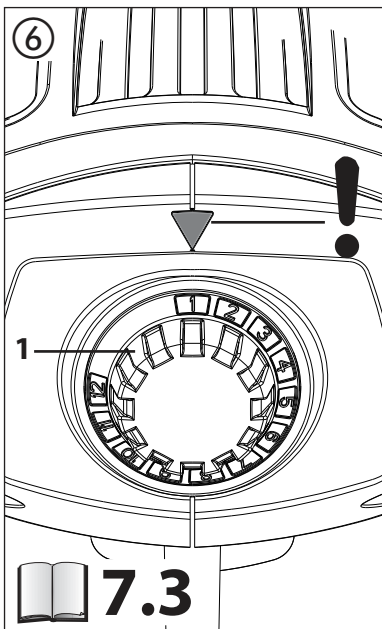
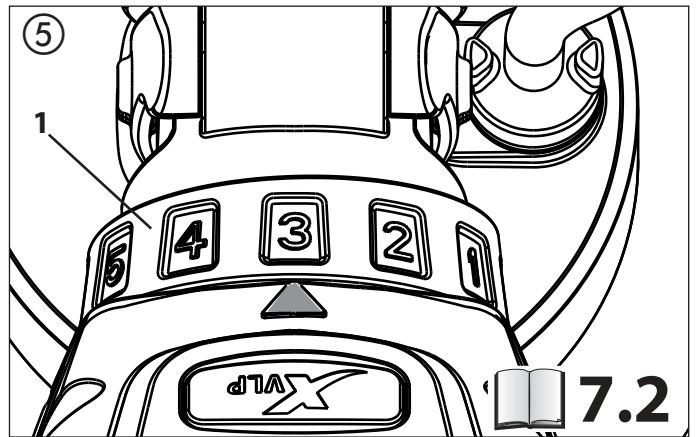
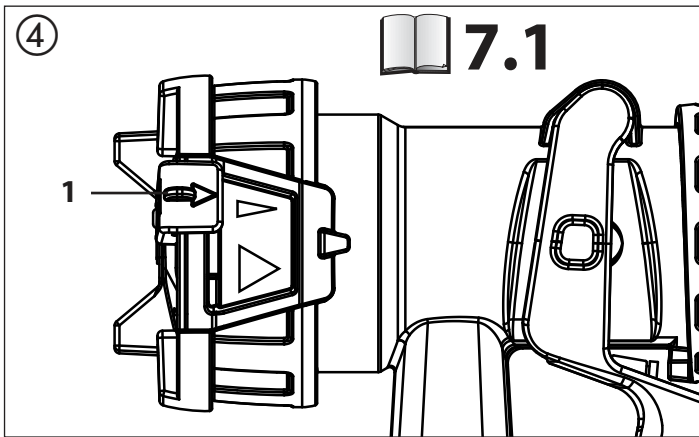

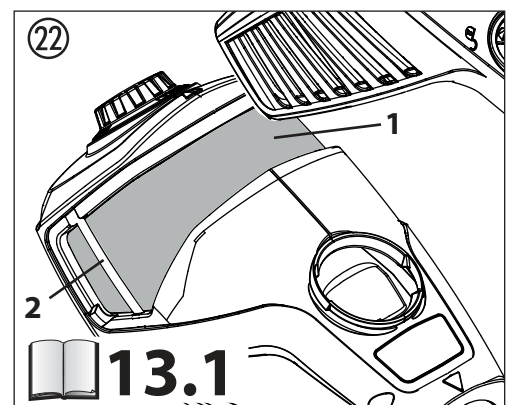
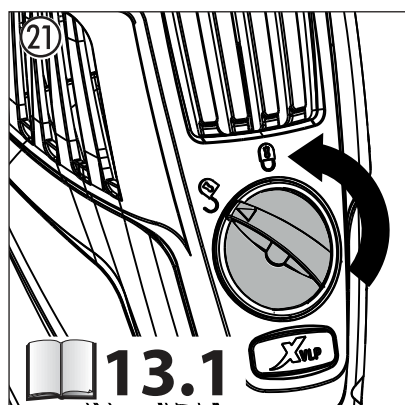
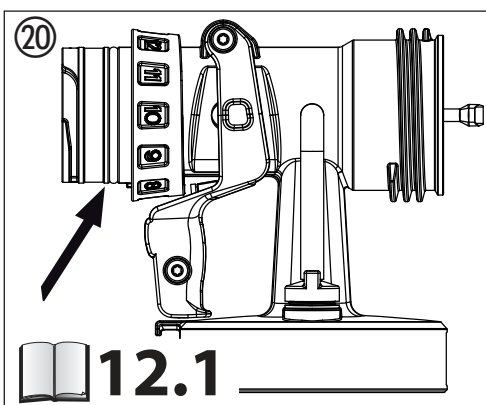
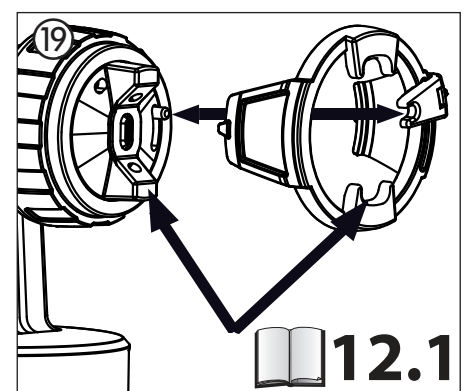
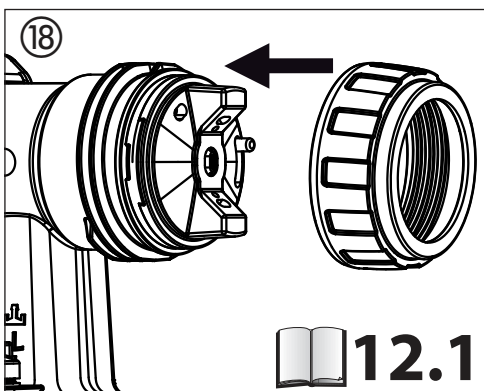
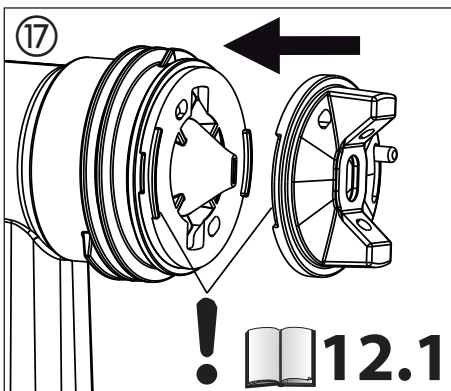
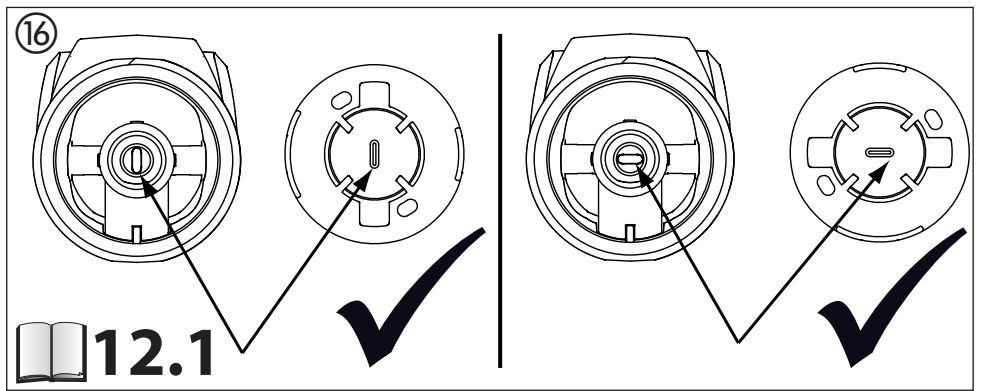
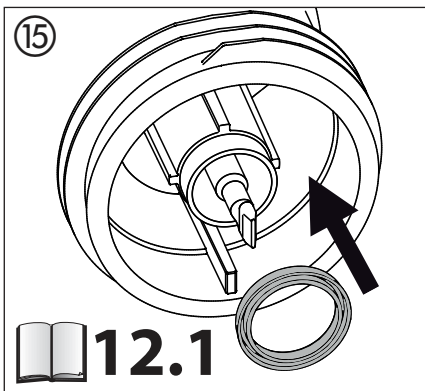
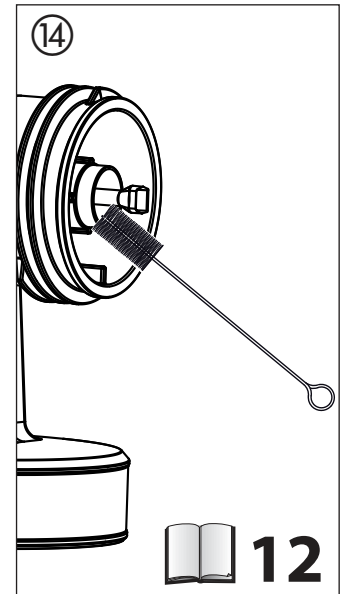
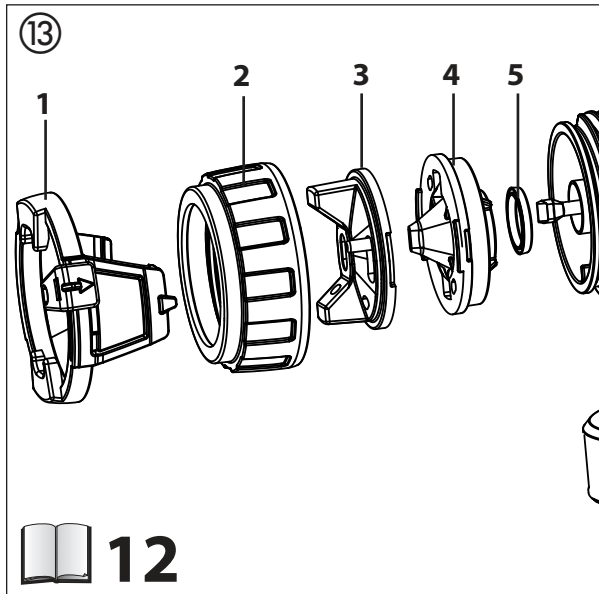
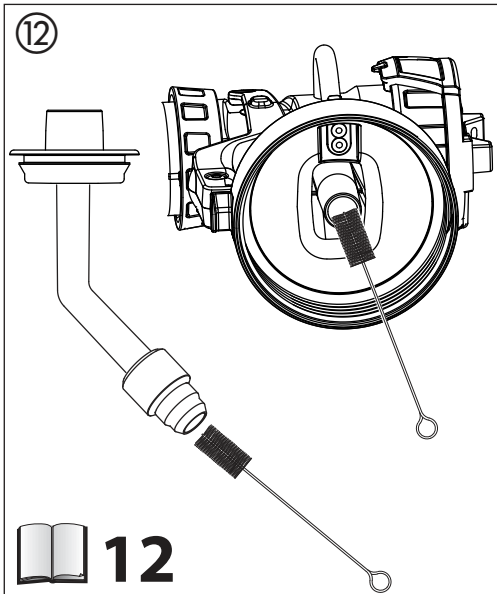

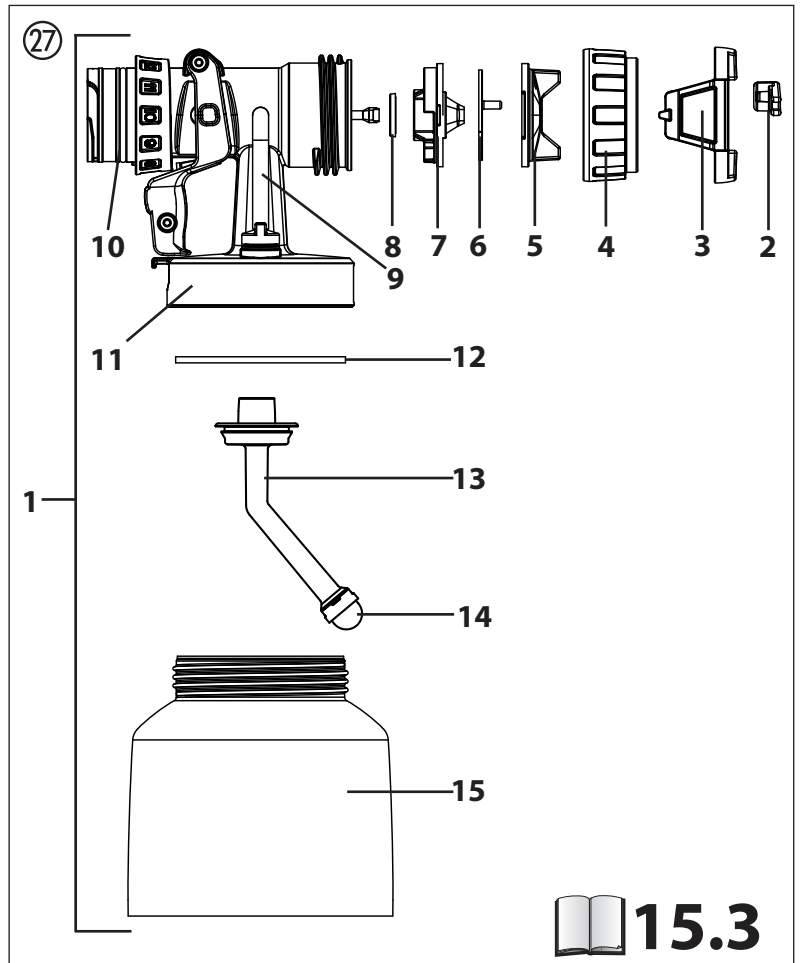
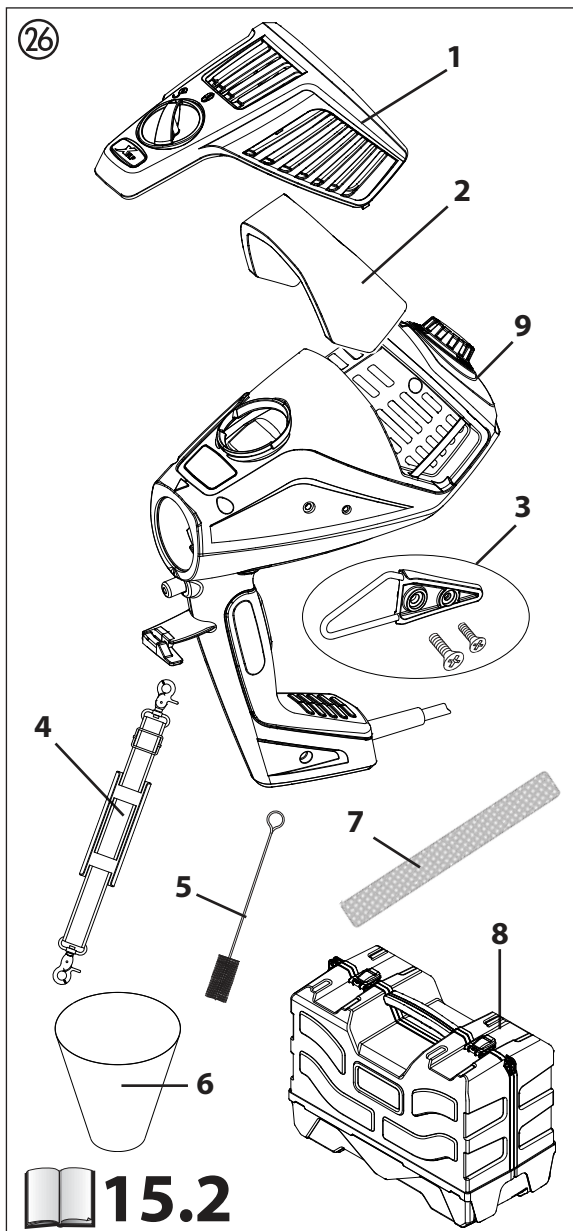
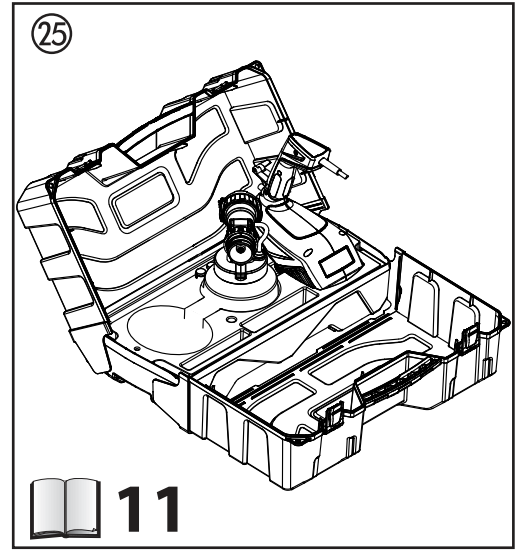
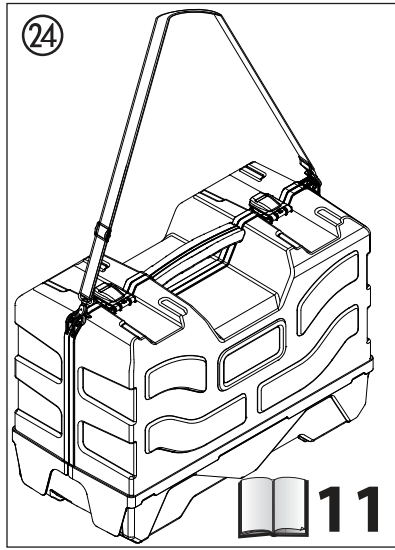
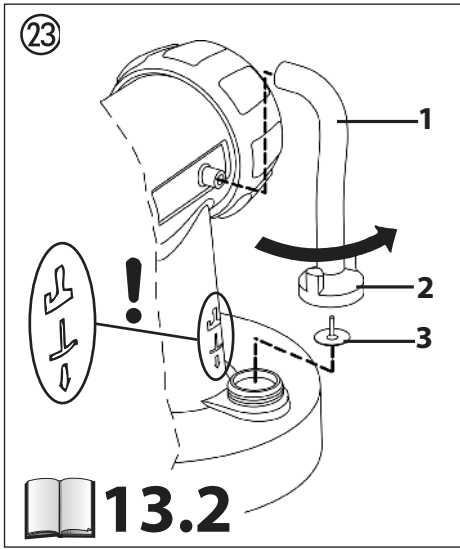





Contents

1	SAFETY REGULATIONS	1
2	EXPLANATORY DIAGRAM	3
3	THE TITAN PLUG 'N' SPRAY SYSTEM	3
3.1	Disassembly of the spray gun	3
4	TECHNICAL DATA	4
5	INTRODUCTION TO SPRAYING USING THE XVLP PROCEDURE	4
6	COATING MATERIAL	4
6.1	Coating Materials Suitable for Use	4
6.2	Coating Materials Not Suitable for Use	4
6.3	Coating materials that can only be processed with relevant spray attachment (accessories)	4
6.4	Preparing the coating material	4
7	SETTING THE SPRAY GUN	5
7.1	Setting the required spray pattern	5
7.2	Setting the amount of material	5
7.3	Setting the amount of air	5
7.4	Align the feed tube	5
8	STARTING OPERATION	5
9	SPRAYING TECHNIQUE	6
10	BREAKS IN WORK	6
11	TRANSPORTATION	6
12	TAKING OUT OF OPERATION AND CLEANING	6
12.1	Assembly	7
13	MAINTENANCE	7
13.1	Air filter	7
13.2	Air relief valve	7
14	CORRECTION OF MALFUNCTIONS	8
15	ACCESSORIES AND SPARE PARTS	9
15.1	Accessories	9
15.2	Spare parts Focus 500	9
15.3	Spare Parts MultiFinish spray attachment	9
	Testing of the unit	11
	Note on disposal	11
	Important information on product liability	11
	Guarantee declaration	11

Explanation of symbols used

	This symbol indicates a potential danger for you or for the device. Under this symbol you can find important information on how to avoid injuries and damage to the device.
	Indicates tips for use and other particularly useful information.
	Refers to the corresponding chapter in the operating manual and the information presented there relating to the illustration.
	Wide spray jet setting
	Narrow spray jet setting

1 SAFETY REGULATIONS

All local safety regulations in force must be observed.

Read the operating instructions carefully and follow the instructions laid down in them in order to avoid risks.

1. Safety at the workplace

- a) **Keep your workplace clean and well lit.**
Disorder or unlit workplaces may result in accidents.
- b) **Never use the tool in hazardous areas that contain flammable liquids, gases or dusts.** *Power tools generate sparks that can ignite the dust or vapors.*
- c) **Keep children and other persons away when using the power tool.** *You can lose control of the tool if you are distracted.*

2. Electrical Safety

- a) **The tool plug must fit into the socket. The plug may not be modified in any form. Do not use adaptor plugs together with protective-earthed tools.**
Unmodified plugs and suitable sockets reduce the risk of an electric shock.
- b) **Avoid physical contact with earthed surfaces such as pipes, heating elements, stoves and refrigerators.**
The risk through electric shock increases if your body is earthed.
- c) **Keep the equipment away from rain and moisture.**
The risk of an electric shock increases if water penetrates electrical equipment.
- d) **Do not misuse the mains lead by carrying the tool by the lead, hanging it from the lead or by pulling on the lead to remove the plug. Keep the lead away from heat, oil, sharp edges or moving tool parts.**
Damaged or twisted leads increase the risk of an electric shock.
- e) **If you work outdoors with a power tool, only use extension cables suitable for outdoor use.** *The use of an extension lead that is suitable for outdoors reduces the risk of an electric shock.*
- f) **If you cannot avoid using the tool in a damp environment, use a residual current operated circuit-breaker.** *Using a residual current operated circuit-breaker avoids the risk of electric shock.*

3. Safety of Persons

- a) **Be attentive. Pay attention to what you are doing and work sensibly with a power tool. Do not use the tool if you are tired or under the influence of drugs, alcohol or medication.** *Just a moment of inattentiveness while using the tool can lead to serious injuries.*

b) **Wear personal safety equipment and always wear safety goggles.** *Wearing personal protective equipment, such as dust mask, non-slip safety shoes, safety helmet or ear protection, depending on the type of power tools, reduces the risk of injury.*

c) **Avoid accidental starting-up. Ensure that the switch is in the "OFF" position before inserting the plug into the socket.** *Accidents can occur if you carry the power tool while your finger is on the switch or if you connect the power tool to the power supply which it is on.*

d) **Remove setting tools or wrenches before switching on the power tool.** *A tool or wrench that is in a rotating tool part can lead to injuries.*

e) **Avoid an unnatural posture.** *This ensures that you can control the tool better in unexpected situations.*

f) **Wear suitable clothing. Do not wear wide clothing or jewellery. Keep your hair, clothes and gloves away from moving parts.** *Loose clothing, jewellery or long hair can be caught in moving parts.*

g) **This appliance is not intended for use by persons (including children) with reduced physical, sensory or mental capabilities, or lack of experience and knowledge, unless they have been given supervision or instruction concerning use of the appliance by a person responsible for their safety.** *Children should be supervised to ensure that they do not play with the appliance.*

4. Careful Handling and Use of Power Tools

- a) **Do not overload the tool. Use the power tool designed for the work that you are doing.** *You work better and safer in the specified performance range if you use the suitable power tool.*
- b) **Do not use power tools whose switch is defective.** *A power tool that cannot be switched on or off is dangerous and has to be repaired.*
- c) **Remove the plug from the socket before carrying out tool settings, changing accessories or putting the tool away.** *This precautionary measure prevents unintentional starting of the tool.*
- d) **Store unused power tools so that they are inaccessible to children. Do not let persons use the tool who are not familiar with it or who have not read these instructions.** *Power tools are dangerous when they are used by inexperienced persons.*
- e) **Take proper care of your tools. Check whether the moving parts function trouble-free and do not jam, whether parts are broken or damaged so that the tool function is impaired.** *Have damaged parts repaired before using the tool. Many accidents have their origin in power tools that have been maintained badly.*
- f) **Use the power tool, accessories, insert tools, etc. in accordance with these instructions and in a fashion specified for this special tool type. Take the working conditions and the activity to be carried out into consideration.** *The use of power tools for purposes other than the intended ones can lead to dangerous situations.*

5. Service

- a) **Have your tool repaired only by qualified specialist personnel and only with original spare parts.** *This ensures that the tool safety is maintained.*
- b) **If the supply cord is damaged, it must be replaced by the manufacturer or its service agent or a similarly qualified person in order to avoid a safety hazard.**

Safety instructions for colour application devices

1. Risks of Fire and Explosion

When spraying flammable coatings vapours from paint and solvents can cause flammable gases to be produced in the work area (hazard area).

Risk of fire and explosion due to ignition sources in this danger zone.

The electrically operated spray device contains potential ignition sources (spark formation when switching the motor on and off, when inserting and removing the power plug, due to potential static electricity at the spray gun)

-> **Device must not be used at operating sites that fall under the explosion protection ordinance.**

-> **Do not use combustible coating substances and cleaning agents -> observe product data sheets!**

-> **Always seal paint or solvent containers tightly in the vicinity of the device.**

-> **When cleaning devices with flammable solvents, disconnect the device from the mains and clean thoroughly with a brush and cloth. Before starting the device up again, ensure that all traces of solvents are removed thoroughly. Allow the cleaned parts to dry completely.**

2. Warning: Danger of injury!

Never point spray gun at yourself, other persons or animals.

3. When spraying paint wear a suitable respirator.

The user should be supplied with a breathing mask. In order to avoid occupational diseases, the working instructions provided by the manufacturer of the materials, solvents and cleaning agents used must be complied with during preparation, working with and cleaning the equipment. Protective clothing, gloves and, if necessary, protective skin cream is required to protect the skin.

4. **Warning: When working with the paint spraying system both indoors and outdoors, ensure that no solvent-based vapours can form within the area of the paint spraying system. When working in closed places a sufficient ventilation must be ensured to remove the solvent vapours.**

5. **Warning: The device is not splash proof. It should not be used, neither outdoors in the rain nor be sprayed with water nor immersed in liquid. Do not use the device in damp or wet environments.**

6. **Attention! Never operate the device if the nozzle seal is missing, damaged or incorrectly mounted. If the nozzle seal is either missing, damaged or incorrectly mounted liquids can enter the device and increase the risk of an electric shock. Check the nozzle seal before each use.**

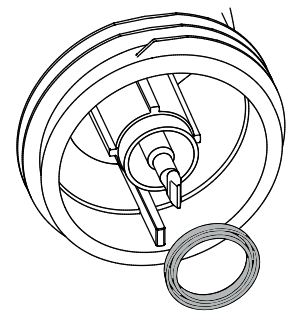

7. The units may only be used with a functional valve. If paints rises in the ventilating hose (Fig. 1, item 19) do not operate the unit further! Dismantle and clean the ventilating hose, valve and diaphragm and replace the diaphragm if necessary.
8. Do not lay the filled spray gun down.
9. Extraction systems should be installed on-site according to the local regulations.
10. The object to be coated must be earthed.
11. Caution against dangers that can arise from the sprayed substance and observe the text and information on the containers or the specifications given by the substance manufacturer.
12. Do not spray any liquid of unknown hazard potential.
13. Before dismantling the spray attachment, relieve pressure by opening the container.
14. **Before working on the device, remove the power plug from the socket.**
15. Work or repairs on the electrical equipment should only be carried out by a professional electrician, even if there are instructions regarding such work in the operating instructions. No liability will be accepted for improper installation.

2 EXPLANATORY DIAGRAM (FIG. 1)

POS.	DESIGNATION	POS.	DESIGNATION
1	Nozzle	15	Container
2	Air cap	16	Suction tube
3	Spray jet width adjusting lever (shaping air)	17	Container seal
4	Spray jet level adjusting ring (vertical/horizontal)	18	Valve
5	Union nut	19	Ventilating hose
6	Spray attachment complete	20	Cleaning brush
7	Material volume regulation	21	Fine feed tube filter (red) Coarse feed tube filter (white)
8	Fixture for shoulder strap	22	Funnel (3 pcs.)
9	Air filter cover lock	23	Replacement air filter (3 pcs.)
10	Air filter cover	24	Carrying strap (for device and transport case)
11	Air volume control	25	Transport case
12	Power cable	26	Velcro to secure the power cable
13	PLUG 'N' SPRAY catch		
14	Trigger (actuates turbine starting switch → material is conveyed)		

3 THE TITAN PLUG 'N' SPRAY SYSTEM

With the Titan PLUG 'N' SPRAY System, the front part of the gun (spray attachment) can be replaced quickly and easily. This enables a rapid material change without cleaning, and ensures that the right tool is available for every material and application.

The following spray attachments are available:

Spray attachment	Area of application
MultiFinish (red) Order No. 2335 658	Spray attachment with slit nozzle and 1000 ml stainless steel container. Processes all standard paints.
FineFinish (brown) Order No. 2335 657	Spray attachment with round nozzle and 1000 ml stainless steel container. Ideal for low-viscosity paints and glazes.
WallFinish (white) Order No. 2335 659	Dispersion spray attachment with slit nozzle and 1400 ml plastic container. Designed for processing dispersions and latex paint.

3.1 DISASSEMBLY OF THE SPRAY GUN

For assembly, insert the spray attachment into the Focus 500 so that the two arrows point at each other. Turn the Focus 500 90° in the arrow direction until it audibly engages. (Fig. 2)

To remove the spray attachment, push the catch (Fig. 2, A) beneath the trigger down and turn the spray attachment by 90°.

4 TECHNICAL DATA

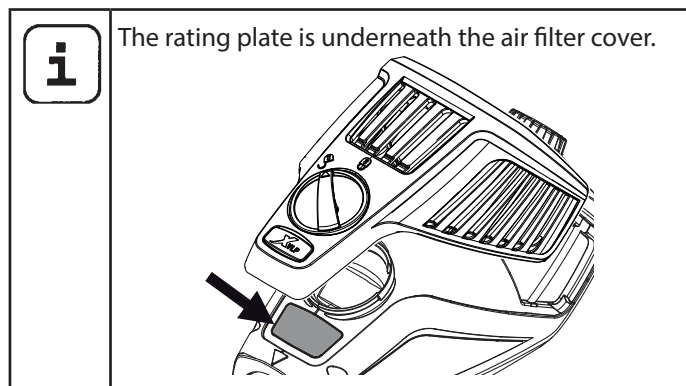

Voltage:	240 V~, 50 Hz
Power consumption:	730 W
Atomizing output:	220 W
Container volume:	1000 ml
Power cable:	4 m
Protection class:	I
Sound pressure level:*	74 dB (A)
Uncertainty K:	4 dB (A)
Sound pressure output:*	87 dB (A)
Uncertainty K:	4 dB (A)
Oscillation level:	<2.5 m/s ²
Uncertainty K:	1.5 m/s ²
Weight (motor-operated blower and spray gun):	2.3 kg

* The acoustic emission value was ascertained in accordance with EN 50144-2-7:2000

5 INTRODUCTION TO SPRAYING USING THE XVLP PROCEDURE

XVLP (Extra Volume Low Pressure) is a low pressure spraying technique, which works with a high volume of air and a low air pressure. The greatest advantage of this spraying technique is the low paint mist formation. This reduces the amount required to cover the object to a minimum.

As opposed to conventional application of coatings, this method achieves a highly economical and perfect surface quality and is, at the same time, environmentally friendly.

Function description

The paint spraying system consists of a motor-operated turbo-blower, which provides the spray gun with atomisation air. In the spray gun, a part of the atomisation air is used to pressurise the container. This pressure causes the coating material to be fed through the uptake pipe to the nozzle where it is

atomised by the rest of the atomisation air. All settings necessary for operation (e.g. material volume) can be conveniently made, directly on the gun.

Field of application

The Focus 500 is designed for smaller to medium-sized projects, i.e. for surfaces of a **maximum of 50 m²**.

6 COATING MATERIAL

6.1 COATING MATERIALS SUITABLE FOR USE

Solvent-based and water-soluble lacquer paints
Mordants, glazes, impregnations, oils, clear varnishes, synthetic enamels, coloured paints, alkyd resin varnishes, primers, radiator paints, hammer effect enamels, anti-rust paints, special-effect paints, textured paints

6.2 COATING MATERIALS NOT SUITABLE FOR USE

Materials that contain highly abrasive components, facade paint, caustic solutions and acidic coating substances.
Flammable materials.

6.3 COATING MATERIALS THAT CAN ONLY BE PROCESSED WITH RELEVANT SPRAY ATTACHMENT (ACCESSORIES)

Interior wall paint (dispersions and latex paint)

6.4 PREPARING THE COATING MATERIAL

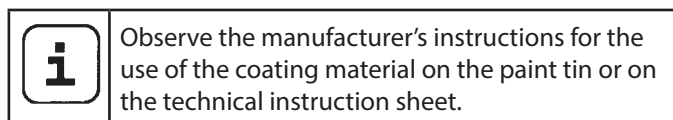

Coating material purity:

An absolute pre-condition for the trouble-free operation of the fine-spray system is that the coating material is uncontaminated. If you have doubts as to the purity of the coating material, we recommend that you first filter it through a fine sieve.

Processing the coating material with the MultiFinish spray attachment (red)

Coating Material	Processing	Comments
Solvent-based lacquer paints	observe manufacturer's instructions	
Water-soluble lacquer paints	observe manufacturer's instructions	

Mordants, glazes, im-pregnations, oils	undiluted	FineFinish spray attachment (brown) recom-mended
Clear varnishes, syn-thetic enamels, col-oured paints, alkyd resin varnishes	observe manufac-turer's instructions	
Primers, radiator paints, hammer ef-fect enamels	observe manufac-turer's instructions	
Anti-rust paints, spe-cial-effect paints	observe manufac-turer's instructions	
Multicolor paints, textured paints	observe manufac-turer's instructions	WallFinish spray attachment (white) recom-mended

7 SETTING THE SPRAY GUN

7.1 SETTING THE REQUIRED SPRAY PATTERN

	Attention: Never pull trigger while adjusting the air cap settings.
--	---

The alignment of the spray jet can be determined by turning the black adjusting ring (Fig. 3, 1).

- A horizontal flat jet** → for vertical surfaces
- B vertical flat jet** → for horizontal surfaces

It is also possible to switch between a wide (▷) and a compact (▷) spray jet with the adjusting lever (Fig. 4, 1).

7.2 SETTING THE AMOUNT OF MATERIAL (FIG. 5)

The material volume can be adjusted incrementally from 1 (minimum) to 12 (maximum) by turning the material volume control (Fig. 5, 1).

7.3 SETTING THE AMOUNT OF AIR (FIG. 6)

Turn the air volume control (Fig. 6, 1) clockwise to increase the air volume or anti-clockwise to reduce the air volume (note arrow on body of gun).

	Setting the air and paint flow rate correctly is important for atomisation, overspray and working speed.
--	--

7.4 ALIGN THE FEED TUBE

If the feed tube is positioned correctly, the container contents can be sprayed without almost any residue. When working on lying objects: Turn the feed tube forwards. (Fig. 7 A) Spraying work when working on overhead objects: Turn the feed tube rearwards. (Fig. 7 B)

8 STARTING OPERATION

Before connecting to the mains supply make sure that the mains voltage corresponds to the operating voltage on the rating plate. The unit must be connected with a properly earthed shock-proof socket.

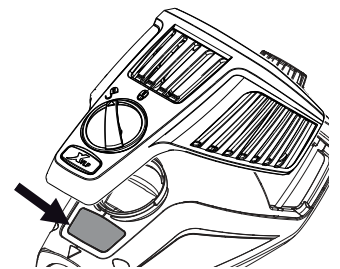

1. Unscrew the container from the spray attachment.
2. Pour in the prepared coating material.

	Fill the container with maximum 1000 ml.	1000ml →	
--	--	----------	--

3. Fit the appropriate filter to the feed tube depending on the coating material used (Fig. 9, 1)
 - Low-viscosity coating materials → Fine filter (red)
 - Viscous coating materials → Coarse filter (white)
4. Align the feed tube. (Fig. 7)
5. Screw the container firmly onto the spray attachment.
6. Connect spray attachment and Focus 500. (Fig. 2)

	When working with the Focus 500 we recommend using the supplied carrying strap. This enables the weight of the Focus 500 to be better distributed and the work can be carried out with less effort.
--	---

7. Both carabiner locks on the carrying strap have to be secured to the fixture. (Fig. 8)

	The fixture for the carrying strap can be mounted to the other side of the Focus 500 if this is preferred. Do this by unscrewing the two large screws (fig. 8, 1). Mount the fixture to the other side by inserting the screws into the relevant holes. Please make sure that you use only the screws that have been provided. Screws of the wrong length or diameter can damage the device. Never tighten the screws without the fixture.
--	---

8. Plug in the power cable.
9. The device is now ready for operation.

9 SPRAYING TECHNIQUE

i The Focus 500 has a trigger with 2 pressure points. The turbine is started via the first pressure point. If the trigger is pressed further, the material is transported.

Operate trigger on the spray gun.

Test spray a piece of cardboard to ensure correct setting of the spray pattern, spray jet width, material and air volume.

Hold the paint spray gun upright and maintain a constant distance of about 3 - 20 cm to the object being sprayed. (Fig. 10)

Move the paint spray gun evenly either from side to side or up and down. If the gun is moved evenly, it will produce an even surface finish.

Always start spraying away from the object and avoid stopping spraying whilst still on the object.

In case of excessive paint mist formation, adjust the air and material flow respectively and alter the distance from the object.

10 BREAKS IN WORK

1. Unplug the power plug.
2. During longer breaks, vent the container by briefly opening and then closing it again.
3. Clean nozzle openings after an interruption in operation.

i In using quick-drying or two-component coating materials, do not fail to rinse unit through with a suitable cleaning agent during the processing period.

11 TRANSPORTATION

! **ATTENTION! Full containers have to be closed tightly when transported in the case. Do not lie the case on its side if it contains full containers of paint.**

1. Detach the carrying strap from the device and secure it to the case (fig. 24).
2. Put the Focus 500 and accessories inside the case as shown in fig. 25 and secure with elastic straps.

i Press the right and left inside of the case lid outwards in order to open up the transport case completely.

12 TAKING OUT OF OPERATION AND CLEANING

i In order to ensure smooth operations, the Focus 500 has to be cleaned thoroughly every day.

1. Divide the spray gun. Press catch (Fig. 2, A) down slightly. Twist the spray attachment and turbine in a counter movement to disconnect them from each other.

! **ATTENTION! Never hold the spray gun rear part under water or immerse it into liquids. Clean the housing only with a moistened cloth.**

2. Unscrew the container. Empty the remaining coating material into the original container.
3. Pre-clean the container and feed tube using a brush and suitable cleaning agent. Clean the ventilating bore. (Fig. 9, 2)
4. Fill the container with a **non-flammable** solvent or water. Screw the container back on. **Do not spray flammable materials for cleaning purposes.**

! **When cleaning devices with flammable solvents, disconnect the device from the mains and clean thoroughly with a brush and cloth. Before starting the device up again, ensure that all traces of solvents are removed thoroughly. Allow the cleaned parts to dry completely.**

5. Connect spray attachment and gun handle. (Fig. 2)
6. Pull the trigger to rinse the spray attachment. Repeat the above procedure until the solvent or water emerging from the nozzle is clear.
7. Turn off the machine and divide the spray gun.
8. Screw off the container and empty it. Unscrew feed tube with container seal. (Fig. 11)
9. Clean feed tube and suction nozzle in spray attachment

with cleaning brush. (Fig. 12)

	CAUTION! Never clean seals, diaphragm and nozzle or air holes of the spray gun with metal objects. The ventilation hose and diaphragm are only solvent-resistant to a limited extent. Do not immerse in solvent, only wipe.
---	--

- Remove the adjusting ring (fig. 13,1) carefully from the union nut (2). Unscrew union nut (2), remove air cap (3), nozzle (4) and nozzle seal (5). Thoroughly clean all parts.

	Take special care when cleaning the interstices on the needle (Fig. 14)
---	---

- Clean the outside of the container with a cloth soaked in solvent or water.
- Assemble the parts again (see "Assembly").

12.1 ASSEMBLY

	ATTENTION! Follow the steps described below exactly for assembly. Otherwise the spray attachment may be damaged.
---	---

	ATTENTION! Never operate the device if the nozzle seal is missing, damaged or incorrectly mounted. If the nozzle seal is either missing, damaged or incorrectly mounted liquids can enter the device and increase the risk of an electric shock.
---	---



- Push nozzle seal onto the needle so that the groove (slot) points away from the spray attachment. (Fig. 15)
- Place nozzle on the needle with recess downwards. **Attention: Position of needle must be congruent with the nozzle aperture. (Fig. 16)**
- Place air cap on nozzle (pay attention to recesses in the air cap). (Fig. 17)
- Screw on union nut. (Fig. 18)
- Snap the adjusting ring into the union nut. (Fig. 19)
Make sure that the two recesses on the adjusting ring are engaged in the air cap clamps and that the lever for adjusting the spray jet width is located on the pin.
- Place the container seal from below on the feed tube and slide it over the collar, while turning the container seal slightly.
- Screw the feed tube with the container seal into the body of the gun.

	In order to mount the gun more easily apply lubricating grease (enclosed) liberally to the O-ring at the spray attachment (Fig. 20).
---	--

13 MAINTENANCE

13.1 AIR FILTER

	Attention! Never operate the device with the air filter soiled or missing, as dirt could be sucked up and affect the operation of the device. Always check the air filter before starting work.
---	--

- Unplug the power plug.
- Release the air filter compartment  (fig. 21) and remove.
- Clean (blow out) or replace the air filter (Fig. 22,1) depending on the degree of soiling.
- Push the clean air filter underneath the fixtures (fig. 22, 2) on the left and right-hand sides (pay attention to the shape of the air filter and compartment).
- Reattach the cover of the air filter compartment and lock .

13.2 AIR RELIEF VALVE

	If paint has entered the ventilation hose, proceed as follows:
---	--

- Pull the ventilating hose (Fig. 23, 1) at the top from the gun body. Screw off the valve cover (2). Remove the diaphragm (3). Clean all the parts carefully.

	CAUTION! The ventilation hose and diaphragm are only solvent-resistant to a limited extent. Do not immerse in solvent, only wipe.
---	--

- Place the diaphragm in the valve cover with the pin facing forward (Also see the marking on the gun body).
- Turn the body of the gun upside down and screw on the valve cover from underneath.
- Place the ventilating hose on the valve cover and on the nipple at the gun body.

14 CORRECTION OF MALFUNCTIONS

MALFUNCTION	CAUSE	REMEDY
The unit will not start	<ul style="list-style-type: none"> • No mains voltage 	<ul style="list-style-type: none"> • Check
No coating material emerges from the nozzle	<ul style="list-style-type: none"> • Nozzle clogged • Material volume setting too low • Paint container seal damaged • No pressure build-up in container • Container empty • Ventilation hose loose/damaged • Feed tube loose • Feed tube / feed tube filter clogged • Air vent on feed tube blocked • Diaphragm stuck • The diaphragm is positioned the wrong way round. 	<ul style="list-style-type: none"> • Clean • Increase volume • Replace • Tighten container • Refill • Insert or replace • Insert • Clean or use another filter • Clean • Remove and clean (see section 13.2) • Position the diaphragm correctly (see section 13.2)
Coating material drips from the nozzle	<ul style="list-style-type: none"> • Air cap, nozzle or needle soiled • Spray attachment incorrectly assembled • Nozzle loose • Nozzle seal is missing or worn • Nozzle worn • Needle worn 	<ul style="list-style-type: none"> • Clean • Assemble correctly (see section 12.1) • Tighten Union nut • Insert an intact nozzle seal • Change • Use new spray attachment
Atomisation too coarse	<ul style="list-style-type: none"> • Material volume too large • Nozzle contaminated • Viscosity of coating material too high • Too little pressure build-up in container • Air filter heavily soiled • Amount of air too low • Air hose damaged 	<ul style="list-style-type: none"> • Reduce volume • Clean • Dilute further • Tighten container • Change (see section 13.1) • Increase volume • Check and replace if necessary
Spray jet pulsates	<ul style="list-style-type: none"> • Coating material in container running out • Nozzle seal is missing or worn • Air filter heavily soiled • Feed tube loose • Feed tube / feed tube filter clogged 	<ul style="list-style-type: none"> • Refill • Insert an intact nozzle seal • Change (see section 13.1) • Insert • Clean or use another filter
The material runs down the object being painted	<ul style="list-style-type: none"> • Too much coating material applied • Distance too small • Incorrect spray attachment 	<ul style="list-style-type: none"> • Reduce volume • Increase distance • Use another spray attachment
Excessive paint mist (overspray)	<ul style="list-style-type: none"> • Distance to the object too large • Too much coating material applied • Amount of air too high • Coating substance over-diluted • Incorrect spray attachment • Incorrect spraying technique 	<ul style="list-style-type: none"> • Reduce distance • Reduce volume • Reduce volume • Reduce degree of dilution • Use another spray attachment • For information about the correct spraying technique, please see chapter 9
Paint in the ventilating hose	<ul style="list-style-type: none"> • Diaphragm soiled • Diaphragm defective 	<ul style="list-style-type: none"> • Clean the diaphragm (see section 13.2) • Replace the diaphragm (see section 13.2)

15 ACCESSORIES AND SPARE PARTS

15.1 ACCESSORIES

POS.	ORDER NO.	DESIGNATION
1	2335 658	MultiFinish spray attachment (yellow) (with 1000 ml container) Processes all standard paints.
2	2335 657	FineFinish spray attachment (brown) (with 1000 ml container) Ideal for low-viscosity paints and glazes.
3	2335 659	WallFinish spray attachment (white) (with 1400 ml container) Designed for processing dispersions.
4	2324 749	Container with cover (1400 ml)

15.2 SPARE PARTS FOCUS 500 (FIG. 26)

POS.	ORDER NO.	DESIGNATION
1	2343 946	Cover of air filter compartment
2	2343 947	Air filter (3 pcs.)
3	2343 948	Fixture for shoulder strap (incl. screws)
4	2344 464	Carrying strap
5	0514 209	Cleaning brush
6	2324 745	Funnel (3 pcs.)
7	2344 041	Velcro to secure the power cable
8	2341 099	Transport case
9	2360 816	Spray gun rear part (including position 1-3)

15.3 SPARE PARTS MULTIFINISH SPRAY ATTACHMENT (RED) (FIG. 27)

POS.	ORDER NO.	DESIGNATION
1	2335 658	MultiFinish spray attachment (red) (with 1000 ml container)
2	2333 179	Spray jet width adjusting lever
3	2314 591	Spray jet adjustment ring
4	2333 180	Union nut (red)
5	2317 807	Air cap
6	2314 585	Air screen
7	2317 423	Nozzle (S 4.1)
8	2323 934	Nozzle seal
9	2304 027	Ventilating hose, valve cover, diaphragm
10	0417 308	O-ring of spray attachment
11	2324 250	Body of gun (including position 8-10)

SPARE PARTS AND ACCESSORIES

TITAN™

POS.	ORDER NO.	DESIGNATION
12	2319 223	Container seal
13	2319 222	Feed tube
14	2324 248	Fine feed tube filter (red, 5 pc.)
	2324 249	Coarse feed tube filter (white, 5 pc.)
15	2322 451	Container with cover 1000 ml
	2315 539	Lubricating grease

TESTING OF THE UNIT

For safety reasons, we would recommend having the device checked by an expert as required but at least every 12 months to ensure that it can continue to operate safely.

In the case of unused devices, the check can be postponed until they are next started up.

All (potentially deviating) national inspection and maintenance regulations must also be observed.

If you have any questions, please contact the customer service team at Titan.

NOTE ON DISPOSAL

In observance of the European Directive 2002/96/EC on waste electrical and electronic equipment and implementation in accordance with national law, this product is not to be disposed of together with household waste material but must be recycled in an environmentally friendly way!



Titan or one of our dealers will take back your used Titan waste electrical or electronic equipment and will dispose of it for you in an environmentally friendly way. Please ask your local Titan service centre or dealer for details or contact us direct.

IMPORTANT INFORMATION ON PRODUCT LIABILITY

According to an EU directive, the manufacturer is only liable without limitation for faults in the product if all parts come from the manufacturer or have been approved by the manufacturer and have been mounted to the device and are operated properly. If third-party accessories or spare parts are used, the manufacturer is exonerated wholly or partly from his/her liability if use of the third-party accessories or spare parts have caused a defect in the product. In extreme cases, the relevant authorities can completely prohibit using the entire device.

With original Titan accessories and spare parts, compliance with all safety regulations is guaranteed

GUARANTEE DECLARATION

Titan Tool, Inc., ("Titan") warrants that at the time of delivery to the original purchaser for use ("End User"), the equipment covered by this warranty is free from defects in material and workmanship. With the exception of any special, limited, or extended warranty published by Titan, Titan's obligation under this warranty is limited to replacing or repairing without charge those parts which, to Titan's reasonable satisfaction, are shown to be defective within thirty-six (36) months after sale to the End User. This warranty applies only when the unit is installed and operated in accordance with the recommendations and instructions of Titan.

This warranty does not apply in the case of damage or wear caused by abrasion, corrosion or misuse, negligence, accident, faulty installation, substitution of non-Titan component parts, or tampering with the unit in a manner to impair normal operation.

Defective parts are to be returned to an authorized Titan sales/service outlet. All transportation charges, including return to the factory, if necessary, are to be borne and prepaid by the End User. Repaired or replaced equipment will be returned to the End User transportation prepaid.

THERE IS NO OTHER EXPRESS WARRANTY. TITAN HEREBY DISCLAIMS ANY AND ALL IMPLIED WARRANTIES INCLUDING, BUT NOT LIMITED TO, THOSE OF MERCHANTABILITY AND FITNESS FOR A PARTICULAR PURPOSE, TO THE EXTENT PERMITTED BY LAW. THE DURATION OF ANY IMPLIED WARRANTIES WHICH CANNOT BE DISCLAIMED IS LIMITED TO THE TIME PERIOD SPECIFIED IN THE EXPRESS WARRANTY. IN NO CASE SHALL TITAN LIABILITY EXCEED THE AMOUNT OF THE PURCHASE PRICE. LIABILITY FOR CONSEQUENTIAL, INCIDENTAL OR SPECIAL DAMAGES UNDER ANY AND ALL WARRANTIES IS EXCLUDED TO THE EXTENT PERMITTED BY LAW.

TITAN MAKES NO WARRANTY AND DISCLAIMS ALL IMPLIED WARRANTIES OF MERCHANTABILITY AND FITNESS FOR A PARTICULAR PURPOSE WITH RESPECT TO ACCESSORIES, EQUIPMENT, MATERIALS OR COMPONENTS SOLD BUT NOT MANUFACTURED BY TITAN. THOSE ITEMS SOLD, BUT NOT MANUFACTURED BY TITAN (SUCH AS GAS ENGINES, SWITCHES, HOSES, ETC.) ARE SUBJECT TO THE WARRANTY, IF ANY, OF THEIR MANUFACTURER. TITAN WILL PROVIDE THE PURCHASER WITH REASONABLE ASSISTANCE IN MAKING ANY CLAIM FOR BREACH OF THESE WARRANTIES.

Subject to modifications

TITAN™

Titan Tool Inc.

International Sales

1770 Fernbrook Lane

Plymouth, MN 55447

USA

international@titantool.com

Fax +1-763-519-3509

Titan Australia

Customer Service 1800 924 637

Email: info@titanpumps.com.au